

## A 0.65V/1µA Nanopower Voltage Detector with Dual Outputs

### FEATURES

- 2V Voltage Detector Test Configuration
- Fully Assembled and Tested
- 2in x 2in 2-layer circuit board

### COMPONENT LIST

DESIGNATION	QTY	DESCRIPTION
C1, C2	2	0.1µF ±10% capacitor (0805)
R3	1	10MΩ ± 1% (0805)
R2	1	4.02MΩ ± 1% (0805)
R1	1	100kΩ ± 1% (0805)
VIN, VDD, REF, OVDD, C-OUT1, C-OUT2	6	Test points
HLDB	1	Jumper
U1	1	TS12001ITD1022

### DESCRIPTION

The demo board for the TS12001 is a completely assembled and tested circuit board that can be used for evaluating the TS12001. The TS12001 voltage detector combines a 0.58V reference and a comparator with resettable comparator latch in a single package. The TS12001 operates from a single 0.65V to 2.5V power supply and consumes less than 1µA total supply current. Optimized for ultra-long life operation, the TS12001 expands Touchstone's growing "NanoWatt Analog™" high-performance analog integrated circuits portfolio.

The voltage detector exhibits a preset UVLO threshold voltage of 0.78V (typ) or can be set to other threshold voltages with two external resistors. The demo board is configured to detect a threshold voltage of 2V. The TS12001 also offers both push-pull and open-drain outputs.

Product datasheet and additional documentation can be found on the factory web site at [www.touchstonesemi.com](http://www.touchstonesemi.com).

### ORDERING INFORMATION

Order Number	Description
TS12001DB	TS12001 Demo Board

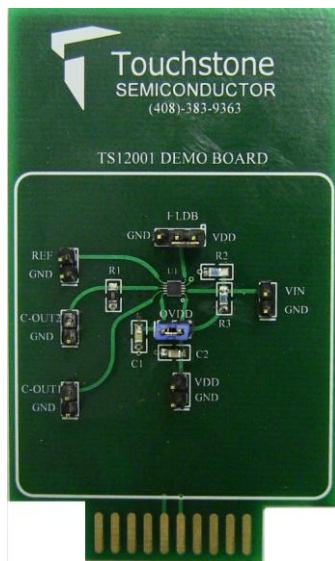

Figure 1. TS12001 Evaluation Board

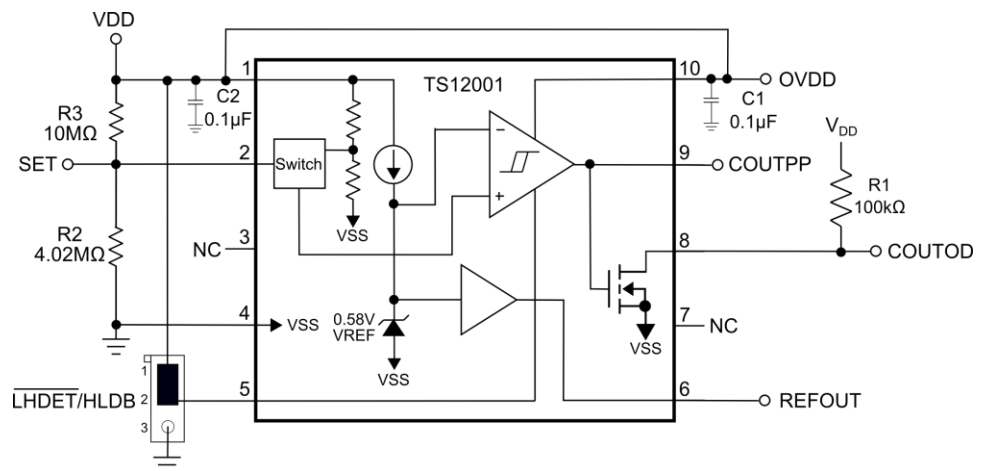

Figure 2. TS12001 Voltage Detector Circuit

## Description

The demo board is configured to detect a threshold voltage of 2V with a voltage divider composed of resistors R2 and R3 as shown in Figure 2. In addition, the output driver supply voltage (OV<sub>DD</sub>) is connected to V<sub>DD</sub> via a jumper. A test point is available to set OV<sub>DD</sub> to a different supply voltage if desired. To detect other voltages, resistor values for R2 and R3 can be changed. The design equation is shown below along with Table 1, which provides R2 and R3 resistor combinations for detecting various V<sub>IN</sub> voltages.

$$R3 = \frac{V_{IN} \times R2 - V_{SET} \times R2}{V_{SET}}$$

V <sub>IN</sub> Threshold Voltage(V)	R3(MΩ)	R2(MΩ)
0.9	2.2	4.02
1.07	3.32	4.02
1.28	4.75	4.02
1.52	6.49	4.02
1.85	8.66	4.02

**Table 1.** Resistor Combinations for Several V<sub>IN</sub> Threshold Voltages

The TS12001 also offers both push-pull and open-drain outputs where the open-drain output has a 100kΩ pull-up resistor.

The TS12001 has a latch enable pin ( $\overline{\text{LHDET}}$ ) that is labeled as HLDB on revision 1 of the demo board. LHDET allows the output of the comparator to latch to a HIGH state under certain conditions. If  $\overline{\text{LHDET}}$  is set HIGH, the COUTPP output will switch based on the input to the comparator. When  $\overline{\text{LHDET}}$  is set LOW and COUTPP is HIGH, COUTPP will remain HIGH until  $\overline{\text{LHDET}}$  goes LOW. When COUTPP is initially LOW instead, COUTPP will latch HIGH until a LOW-to-HIGH transition occurs on the COUTPP output. In essence, the  $\overline{\text{LHDET}}$  pin offers a LOW-to-HIGH detection. However,  $\overline{\text{LHDET}}$  must not be left open. The open-drain output, COUTOD, is the inverter version of the COUTPP output. Connect  $\overline{\text{LHDET}}$  to V<sub>DD</sub> for normal operation or to GND for  $\overline{\text{LHDET}}$  enable.  $\overline{\text{LHDET}}$  is connected to GND by default.

## Quick Start Procedures

### Required Equipment

- TS12001 demo board
- DC Power Supply, Single Output
- Agilent 34401A DMM

Signal	TS12001
V <sub>DD</sub>	VDD
OV <sub>DD</sub>	OVDD
GND	GND
SET	VIN
COUTPP	C-OUT1
COUTOD	C-OUT2
REFOUT	REF
<b>Jumper Setting</b>	
$\overline{\text{LHDET}}/\overline{\text{HLDB}}$	1-2

**Table 2.** Test Points and Jumper Setting

In order to evaluate the TS12001 voltage detector, the following steps are to be performed:

- 1) Before connecting the DC power supply to the demo board power test point, turn on the power supply and set the DC voltage to 2.5V and then turn it off.
- 2) Connect the positive terminal of a DMM to test point C-OUT1 and the ground terminal to test point GND. Make sure the DMM is set to measure voltage.
- 3) Connect the positive terminal of the DC power supply to test point VDD and the ground terminal to test point GND.
- 4) Turn on the power supply and check that the power supply current is approximately 30μA, which is primarily due to the open-drain pull-up resistor R1. At this time, the voltage the DMM is measuring should be approximately 2.5V.
- 5) Reduce the DC supply voltage slowly and observe the DMM voltage. When the DC supply voltage drops to approximately 2V, the DMM voltage should drop to approximately 0V. This corresponds to a voltage detection of 2V. The power supply current is approximately 1.1μA. The open-drain output voltage (C-OUT2) is the inverted version of C-OUT1.

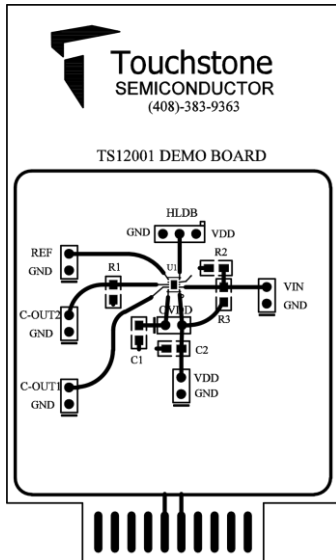

Figure 3. Top Layer Component View

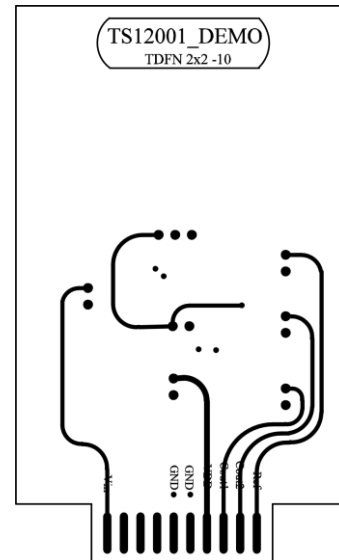

Figure 4. Bottom Layer (GND)