

FEATURES

- 2 output pads for output loading
- Fully Assembled and Tested
- 2in x 1in 2-layer circuit board

COMPONENT LIST

DESIGNATION	QTY	DESCRIPTION
C2	1	0.1 μ F \pm 10% capacitors (0805)
U1	1	TS6001AIG325 Voltage Reference
VIN, VOUT, GND	4	Test points

DESCRIPTION

The demo board for the TS6001-2.5V is a completely assembled and tested circuit board that can be used for evaluating the TS6001-2.5V voltage reference.

The TS6001-2.5V demo board provides an on-board 0.1 μ F decoupling capacitor at the input. Two pads are available at the output to accommodate a capacitive load and a resistive load. The demo board includes a supply test point with a dedicated ground test point as well as an output test point with a dedicated ground test point.

The TS6001-2.5V is available in a PCB-space saving 3-lead SOT23 surface-mount package.

Product data sheets and additional documentation can be found on the factory web site at www.touchstonesemi.com.

ORDERING INFORMATION

Order Number	Description
TS6001G3-2.5DB	Demo Board

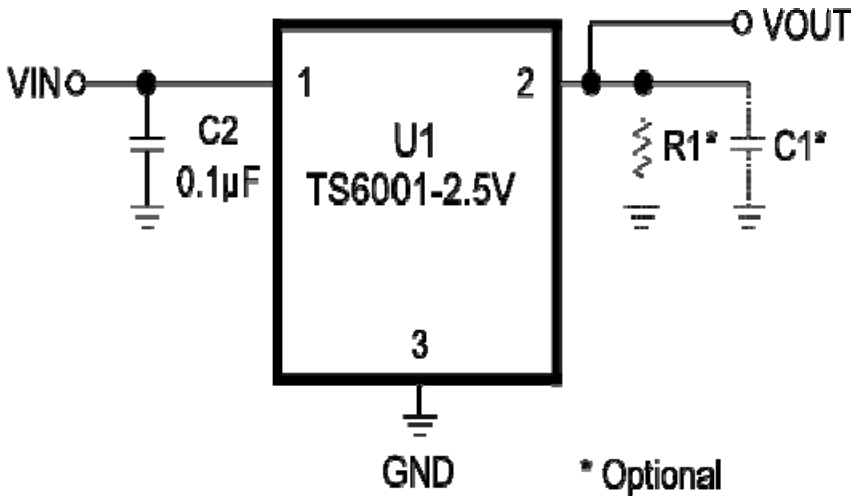

Figure 1. TS6001 Evaluation Board Circuit



Figure 2. TS6001 Evaluation Board

DESCRIPTION

The demo board provides an on-board 0.1 μ F decoupling capacitor at the VIN input. Two pads are available at the output to accommodate a capacitive load and a resistive load as needed.

QUICK START PROCEDURES

Required Equipment

- TS6001DB demo board
- A DC Power Supply, Single, an HP Model HP6624A or equivalent
- A digital voltmeter, an HP34410A or equivalent
- A digital ammeter, an HP34410A or equivalent

To evaluate the TS6001 voltage reference, the following steps are to be performed:

- 1) Before connecting the DC power supply to the demo board, turn on the power supply and set the DC voltage to 5V and then turn it off.
- 2) Connect the DC power supply positive terminal to the negative terminal of the digital ammeter. Then, connect the positive terminal of the ammeter to the test point VIN and the negative terminal of the DC power supply to the adjacent test point GND.

- 3) Connect the positive terminal of the digital voltmeter to test point VOUT and the negative terminal to the adjacent test point GND.
- 4) An optional load resistor $\geq 5k\Omega$ and capacitor up to 2200pF can be soldered on the board. Solder the resistor on pads R1 and the capacitor on pads C1. If a load is not desired, leave these pads open and proceed to step 5.
- 5) Turn on the power supply and check that the digital voltmeter is reading an output voltage within $\pm 0.2\%$ of 2.5V and the digital ammeter is reading a supply current less than 35 μ A.
- 6) The input voltage VIN can vary from VOUT + 0.2V to 12.6V as needed. Please refer to the TS6001 product datasheet "Electrical Characteristics" section for more information.

Note: In order to add a Kelvin connection to the output test point VOUT, connect the positive terminal of a DVM to VOUT and the negative terminal to GND. Then, place a resistor and/or capacitor on pads R1 and/or pads C1, respectively. For an accurate VOUT measurement, always connect the positive terminal of the DVM to the VOUT test point.

If additional loading is needed on the output VOUT, a wire can be soldered on pads R1 and C1. Then, a load can be connected to the other end of the wire. Make sure the load is connected to the ground on the board.

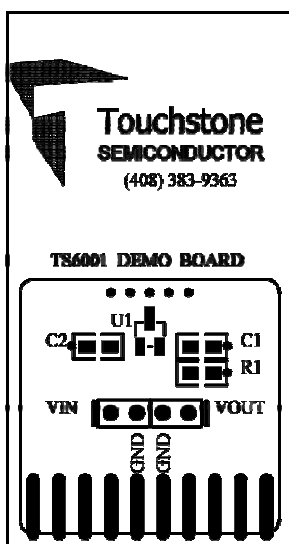

Figure 3. Top Layer Component View

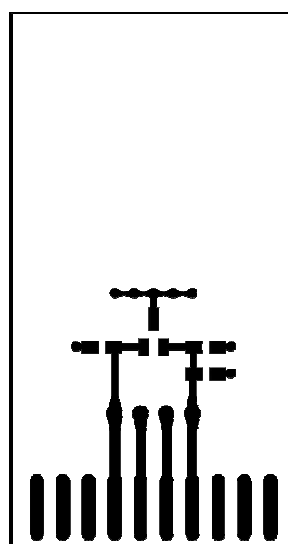

Figure 4. Top Layer Trace View



Figure 5. Bottom layer (GND)