

7879-1(***)*		7879-2(***)*	
PART NO.	ENG. NO	PART NO.	ENG. NO
08-55-0124	7879-1(P208)	50-29-1744	7879-2(P228)
08-55-0129	7879-1(P154)	50-29-1745	7879-2(P228)L
		46999-0460	7879-2(P154)
		46999-0461	7879-2(P154)L
50-29-1900	7879-1(P154)		
46999-0101	7879-1(P154)L		

- NOTES:
1. MATERIAL: SEE LEGEND.
  2. FINISH: SEE LEGEND.
  3. THIS PART CONFORMS TO PRODUCT SPEC. 7879.
  4. PACKAGING SPECIFICATION: SEE LEGEND
  5. CRIMP FOR 24-30 AWG. WIRE WITH .060(1.52) MAX. INSULATION DIA.
  6. THIS TERMINAL TO BE USED IN 7880 HOUSING.
  7. DIMENSIONS GIVEN ACROSS CENTERLINES ARE SYMMETRICAL ABOUT THOSE CENTERLINES WITHIN HALF THE TOTAL TOLERANCE.
  8. CRIMP WILL ACCEPT 22 AWG. WIRE WITH .062(1.57) MAX. INSULATION DIA.
  9. THIS PART CONFORMS TO CLASS B REQUIREMENTS OF COSMETIC SPECIFICATION PS-45499-002.

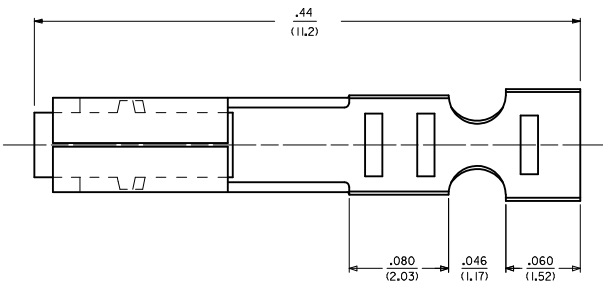
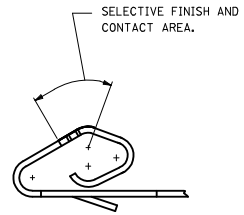

LEGEND:

7879-\*(\*\*\*)\*

MATERIAL .008/ (0.20) THICK  
 1 = BRASS  
 2 = PHOS. BRONZE

FORM  
 BLANK = REEL, PER WINDING DETAIL B  
 L = LOOSE, PER PK-2759-001

PLATING

(P154) OVERALL TIN: .00100/(0.00254) MIN. OVERALL NICKEL UNDERPLATE: .000050/(0.00127) MIN.  
 (P208) SELECT GOLD: .000015/(0.00038) MIN. SELECT TIN: .000100/(0.00254) MIN. OVERALL NICKEL UNDERPLATE: .000050/(0.00127) MIN.  
 (P228) SELECT GOLD: .000030/(0.00076) MIN. SELECT TIN: .000100/(0.00254) MIN. OVERALL NICKEL UNDERPLATE: .000050/(0.00127) MIN.

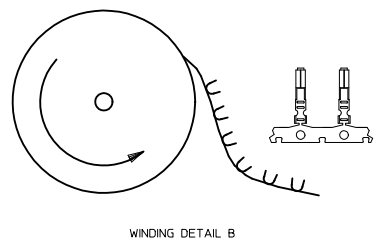
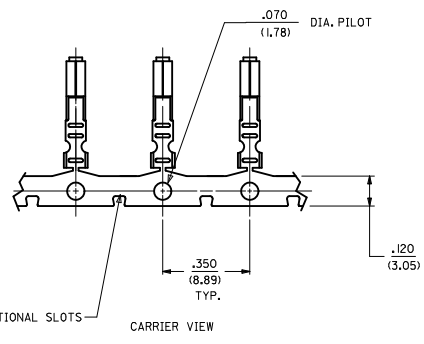
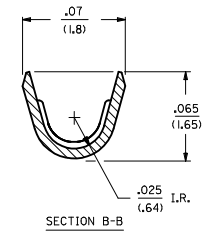
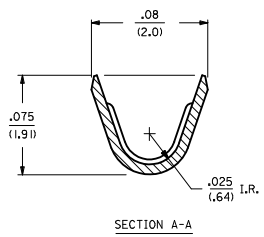
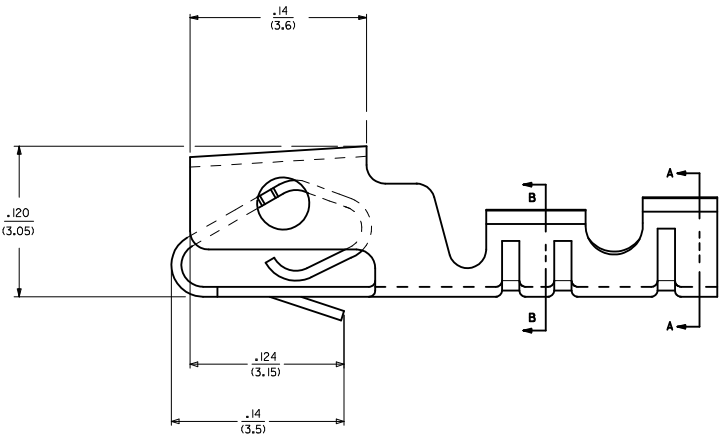
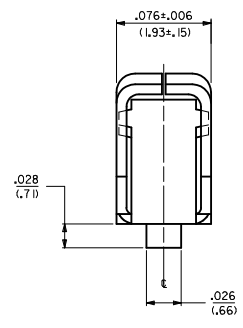

<b>ADD PART NUMBERS</b> ELEC NO: UCP2012-3565 DRAWN BY: DRW/MHSTROH CHECKED BY: CHY/DHK/PPER APPROVED BY: MTH DATE: 2012/05/04 DATE: 2012/05/04 DATE: 2012/05/04 REV: AA1	QUALITY SYMBOLS ▽=0 ▽=0 ▽=0	GENERAL TOLERANCES (UNLESS SPECIFIED) mm INCH 4 PLACES ±.010 ±.010 3 PLACES ±.025 ±.014 2 PLACES ±0.25 ±.014 1 PLACE ±0.36 ±.014 0 PLACE ±.010 ±.010 ANGULAR ±1/2° DRAFT WHERE APPLICABLE MUST REMAIN WITHIN DIMENSIONS	DIMENSION STYLE IN/MM DRAWN BY: GUZIK DATE: 12/22/88 CHECKED BY: PATEL DATE: 12/22/88 APPROVED BY: LENZ DATE: 12/22/88	SCALE: --- DESIGN UNITS: INCH THIRD ANGLE PROJECTION	TITLE: (2.54)/100 KK. CRIMP TYPE SHROUDED TERMINAL MATERIAL NO: SEE CHART DOCUMENT NO: SD-7879	SHEET NO: 1 OF 1
	<p style="text-align: center;"><b>molex</b></p>					
	THIS DRAWING CONTAINS INFORMATION THAT IS PROPRIETARY TO MOLEX INCORPORATED AND SHOULD NOT BE USED WITHOUT WRITTEN PERMISSION					
	SIZE D					