

		Revision	
Rev.	Description	Date	Approved

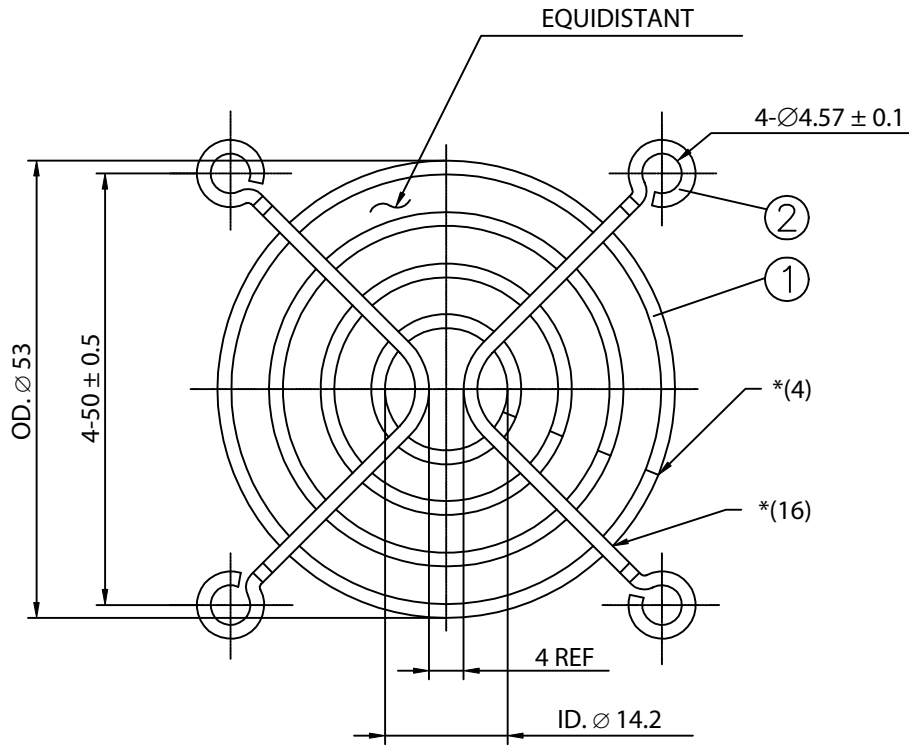

NOTE:

- MATERIAL: SAE, 1008(OR EQUIVALENT).
BRIGHT BASIC WIRE
- FINISH: BRIGHT NICKEL-CHROME (TRIVALENT CHROME) PLATING
- 0.30 ± 0.05 DEPTH OF SERRATIONS ON WIRE.
- WELD JOINTS TO WITHSTAND 50 LBS. PULL FORCE.
- RING: Ø1.6: RIB: Ø1.6
- GENERAL TOLERANCE UNLESS NOTED IS ± 015*** & ± 030**
- UNIT: mm
- RoHS COMPLIANT

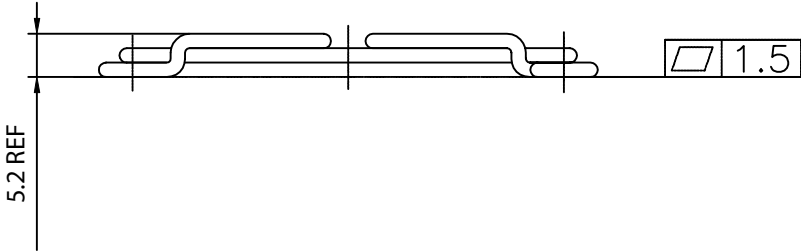

Dim range (mm)	Tolerance +/- (mm)	Qualtek Electronics Corp. FAN-S DIVISION		
0-1	0.15	Part Number: 08147		RoHS Compliant
1-6	0.20	Description: WIRE FORM FAN GUARD (60mm)		
6-18	0.30		UNIT: mm	Rev B
18-50	0.50	Drawn / Date	Checked / Date	Approved / Date
50-120	0.70	B. Grubb 08-18-06	08-18-06	JJH / 08-18-06
120-250	0.90			
250-500	1.20			