

10	9	8	7	6	5	4	3	2	1	
MATERIAL NUMBER	ENGINEERING NUMBER	MATERIAL NUMBER ON TAPE	ENGINEERING NUMBER ON TAPE	STUD SIZE	HOLE "S" ± 0.005 ± 0.03	"D" MAX	"H" ± 0.10 ± 0.25	"L" MAX	"T" REF	ID MIN
191640085	SA-221-06	---	---	#6	$\varnothing .146/3.71$	$\varnothing .32/8.1$	---	1.46/37.1	.028/0.71	.064/1.63
191640086	SA-221-08	191640419	SA-221-08T	#8	$\varnothing .173/4.39$	$\varnothing .32/8.1$.534/13.56	1.46/37.1	.028/0.71	.064/1.63
191640003	SA-221-10	191640306	SA-221-10T	#10	$\varnothing .198/5.03$	$\varnothing .32/8.1$.534/13.56	1.46/37.1	.028/0.71	.064/1.63
191640004	SA-222-14	191640844	SA-222-14T	1/4	$\varnothing .265/6.73$	$\varnothing .48/12.2$.340/8.65	1.66/42.2	.028/0.71	.055/1.40
191640005	SA-226-38	191640845	SA-226-38T	3/8	$\varnothing .390/9.91$	$\varnothing .54/13.7$.328/8.33	1.95/49.5	.032/0.81	.055/1.40

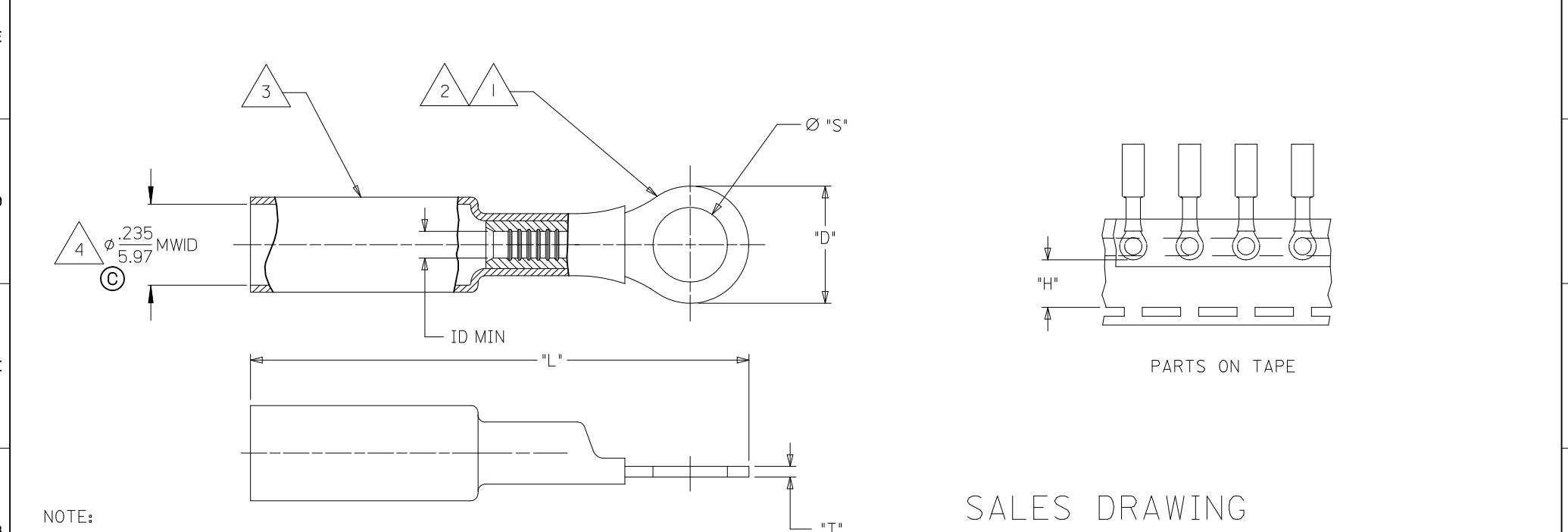

- NOTE:
- 1. TERMINAL MATERIAL: COPPER ALLOY
 - 2. FINISH: ELECTRO TIN PLATE.
 - 3. INSULATION MATERIAL: HEAT SHRINKABLE TUBING WITH HOTMELT ADHESIVE INNER LINER. COLOR: RED.
 - 4. MWID = MAXIMUM WIRE INSULATION DIAMETER.

SALES DRAWING

CHANGED MWID EC NO: ETC2006-0154 DRAWN: ASAYDEH 2005/12/21 CHKD: JLOMASTRO 2005/12/21 APPR: JPAMLICK 2005/12/21	DESCRIPTION RING TONGUE TERMINAL PERMA-SEAL NIAC 22-18 AWG	QUALITY SYMBOLS	GENERAL TOLERANCES (UNLESS SPECIFIED)	DIMENSION STYLE	SCALE	DESIGN UNITS	THIRD ANGLE PROJECTION																																	
		$\nabla=0$ $\nabla E=0$	<table border="1"> <tr> <th></th> <th>mm</th> <th>INCH</th> </tr> <tr> <td>4 PLACES</td> <td>\pm---</td> <td>\pm---</td> </tr> <tr> <td>3 PLACES</td> <td>± 0.13</td> <td>$\pm .005$</td> </tr> <tr> <td>2 PLACES</td> <td>± 0.25</td> <td>$\pm .010$</td> </tr> <tr> <td>1 PLACE</td> <td>\pm---</td> <td>\pm---</td> </tr> </table>		mm	INCH	4 PLACES	\pm ---	\pm ---	3 PLACES	± 0.13	$\pm .005$	2 PLACES	± 0.25	$\pm .010$	1 PLACE	\pm ---	\pm ---	<table border="1"> <tr> <th>IN/MM</th> <th>DRAWN BY</th> <th>DATE</th> </tr> <tr> <td></td> <td>BENDERLE</td> <td>2005/5/14</td> </tr> <tr> <td></td> <th>CHECKED BY</th> <th>DATE</th> </tr> <tr> <td></td> <td>HBEITZEL</td> <td>2005/5/14</td> </tr> <tr> <td></td> <th>APPROVED BY</th> <th>DATE</th> </tr> <tr> <td></td> <td>RDEROSS</td> <td>2005/5/14</td> </tr> </table>	IN/MM	DRAWN BY	DATE		BENDERLE	2005/5/14		CHECKED BY	DATE		HBEITZEL	2005/5/14		APPROVED BY	DATE		RDEROSS	2005/5/14	---	INCH	
			mm	INCH																																				
		4 PLACES	\pm ---	\pm ---																																				
3 PLACES	± 0.13	$\pm .005$																																						
2 PLACES	± 0.25	$\pm .010$																																						
1 PLACE	\pm ---	\pm ---																																						
IN/MM	DRAWN BY	DATE																																						
	BENDERLE	2005/5/14																																						
	CHECKED BY	DATE																																						
	HBEITZEL	2005/5/14																																						
	APPROVED BY	DATE																																						
	RDEROSS	2005/5/14																																						
DRAFT WHERE APPLICABLE MUST REMAIN WITHIN DIMENSIONS		MATERIAL NO. SEE CHART SIZE B	DOCUMENT NO. SD-19164-006 MOLEX INCORPORATED	SHEET NO. 1 OF 1																																				