

13	12	11	10	9	8	7	6	5	4	3	2	1					
UNPLATED MATERIAL NUMBER	UNPLATED ENG. NUMBER	UNPLATED MAT. NO. ON TAPE	UNPLATED ENG. NO. ON TAPE	PLATED MATERIAL NUMBER	PLATED ENGINEERING NUMBER	PLATED MAT. NO. ON TAPE	PLATED ENG. NO ON TAPE	SEE DETAIL	STUD SIZE	WIRE RANGE	"S"	"L"	"W"	"C"	"B"	"T"	
J	192210408	BCL-810	190820012	BCL-810T	192210223	BCL-810-PL	190820011	BCL-810-PLT	A	10/4.8mm	8 AWG/10mm ²	.214/5.45	1.187/30.15	.438/11.13	.376/9.55	.185/4.70	.070/1.78
	192210409	BCL-814	190820014	BCL-814T	192210224	BCL-814-PL	190820013	BCL-814-PLT	A	1/4"/M6	8 AWG/10mm ²	.278/7.06	1.187/30.15	.438/11.13	.376/9.55	.185/4.70	.070/1.78
	192210562	BCL-814-WP	---	---	192210563	BCL-814-WP-PL	---	---	---	1/4"/M6	8 AWG/10mm ²	.278/7.06	1.313/33.35	.594/15.09	.376/9.55	.185/4.70	.070/1.78
	192210411	BCL-8516	190820017	BCL-8516T	192210225	BCL-8516-PL	---	---	A	5/16"/M8	8 AWG/10mm ²	.340/8.63	1.187/30.15	.438/11.13	.376/9.55	.185/4.70	.070/1.78
	192210482	BCL-8516-WP	---	---	192210483	BCL-8516-WP-PL	190820016	BCL-8516-PLT	B (L1)	5/16"/M8	8 AWG/10mm ²	.340/8.63	1.313/33.35	.594/15.09	.422/10.72	.185/4.70	.070/1.78
	192210410	BCL-838-WP	190820015	BCL-838-WPT	192210226	BCL-838-WP-PL	192210566	BCL-838-WP-PLT	B (L1)	3/8"/M9	8 AWG/10mm ²	.400/10.16	1.313/33.35	.594/15.09	.422/10.72	.185/4.70	.070/1.78
I	192210481	BCL-838-XWP	---	---	192210484	BCL-838-XWP-PL	---	---	---	3/8"/M9	8 AWG/10mm ²	.400/10.16	1.469/37.31	.766/19.46	.394/10.01	.185/4.70	.070/1.78
	192210415	BCL-812-XWP	---	---	192210414	BCL-812-XWP-PL	---	---	---	1/2"/M12	8 AWG/10mm ²	.520/13.21	1.469/37.31	.766/19.46	.394/10.01	.185/4.70	.070/1.78
	192210425	BCL-610	---	---	192210424	BCL-610-PL	190820003	BCL-610-PLT	B	10/4.8mm	6 AWG/16mm ²	.214/5.45	1.281/32.54	.438/11.13	.345/8.75	.232/5.89	.075/1.90
	192210406	BCL-614-WP	190820006	BCL-614T	192210227	BCL-614-WP-PL	190820005	BCL-614-PLT	B	1/4"/M6	6 AWG/16mm ²	.278/7.06	1.406/35.72	.594/15.09	.430/10.92	.232/5.89	.080/2.03
	192210494	BCL-614	---	---	192210495	BCL-614-PL	192210498	BCL-614-PLT	B	1/4"/M6	6 AWG/16mm ²	.278/7.06	1.281/32.54	.438/11.13	.345/8.75	.232/5.89	.075/1.90
	192210407	BCL-6516-WP	---	---	192210228	BCL-6516-WP-PL	190820009	BCL-6516-PLT	B	5/16"/M8	6 AWG/16mm ²	.340/8.63	1.406/35.72	.594/15.09	.352/8.94	.232/5.89	.080/2.03
	192210493	BCL-6516	190820010	BCL-6516T	192210492	BCL-6516-PL	192210499	BCL-6516-PLT	B	5/16"/M8	6 AWG/16mm ²	.340/8.63	1.281/32.54	.438/11.13	.345/8.75	.232/5.89	.075/1.90
H	192210384	BCL-638-WP	190820008	BCL-638T	192210229	BCL-638-WP-PL	190820007	BCL-638-PLT	B	3/8"/M9	6 AWG/16mm ²	.400/10.16	1.406/35.72	.594/15.09	.352/8.94	.232/5.89	.080/2.03
	192210569	BCL-638-XWP	---	---	192210568	BCL-638-XWP-PL	---	---	---	3/8"/M9	6 AWG/16mm ²	.400/10.16	1.563/39.70	.766/19.46	.422/10.72	.232/5.89	.080/2.03
	192210417	BCL-612-XWP	---	---	192210416	BCL-612-XWP-PL	190820004	BCL-612-PLT	B	1/2"/M12	6 AWG/16mm ²	.520/13.21	1.563/39.70	.766/19.46	.352/8.94	.232/5.89	.080/2.03

(L1) (L1)

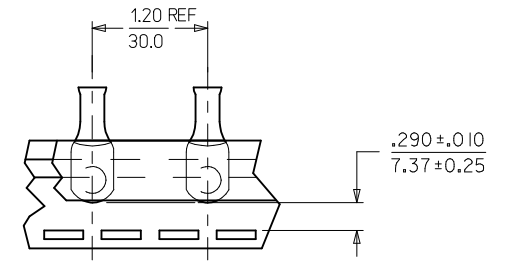
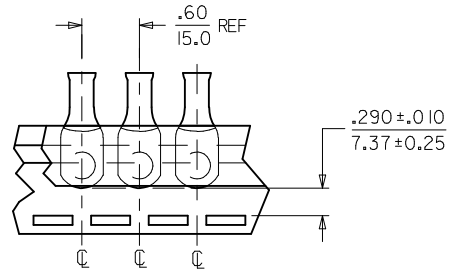
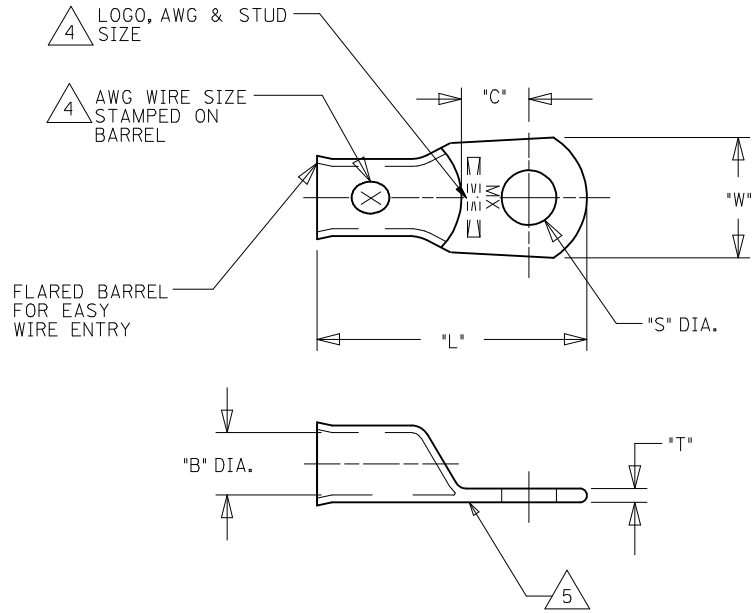

DETAIL A

DETAIL B

SALES DRAWING

- NOTES:
- FOR INSPECTION SIGHT HOLE, PLEASE CONSULT FACTORY.
 - OTHER STUD SIZES MAY BE AVAILABLE, PLEASE CONSULT FACTORY.
 - MATERIAL: COPPER
PLATING: TIN
 - MARKINGS CAN BE AT EITHER LOCATION SHOWN.
 - IF TONGUE IS TO BE BENT AT ANY ANGLE, IT MUST BE BENT AROUND A RADIUS ONE HALF THE TONGUE THICKNESS.
 - ALL PARTS ARE ROHS COMPLIANT.

TOLS. METRIC WIRE+STUD EC NO: IPG2013-0474 DRAWN:THRODAHL 2012/02/21 CHKD:JMACNEIL 2012/02/21 APPR:JMACNEIL 2013/05/01	QUALITY SYMBOLS ▽=0 ▽=0	GENERAL TOLERANCES (UNLESS SPECIFIED)		DIMENSION STYLE IN/MM		SCALE ---	DESIGN UNITS INCH	THIRD ANGLE PROJECTION			
		4 PLACES ± ---	3 PLACES ± ---	2 PLACES ± ---	1 PLACE ± ---	ANGULAR ± ---°	DRAWN BY DMYRICK		DATE 2005/5/3	TITLE EYELET STYLE COPPER TERMINALS 8 AND 6 AWG LUGS	
L1	REV	DRAFT WHERE APPLICABLE MUST REMAIN WITHIN DIMENSIONS		MATERIAL NO. SEE CHART		APPROVED BY RDEROSS		DATE 2005/5/3		MOLEX INCORPORATED	
				SD-19221-001		SHEET NO. 1 OF 1		THIS DRAWING CONTAINS INFORMATION THAT IS PROPRIETARY TO MOLEX INCORPORATED AND SHOULD NOT BE USED WITHOUT WRITTEN PERMISSION			

	10	9	8	7	6	5	4	3	2	1		
	MATERIAL NUMBER	ENGINEERING NUMBER	AWG RANGE	COLOR CODE	STUD SIZE	"S"	"L"	"W"	"P"	"X"	"D"	"T"
F	192210212	HDC-810-CC	8	RED	10	.214	1.125	.343	.531	.250	.250	.078
F	192210215	HDC-610-CC	6	BLUE	10	.214	1.187	.406	.562	.250	.281	.078
F	192210213	HDC-614-CC	6	BLUE	1/4	.278	1.187	.406	.562	.250	.281	.078
F	192210216	HDC-410-CC	4	GRAY	10	.214	1.343	.500	.640	.296	.359	.109
F	192210214	HDC-414-CC	4	GRAY	1/4	.278	1.343	.500	.640	.296	.359	.109
F	192210217	HDC-4516-CC	4	GRAY	5/16	.340	1.500	.500	.781	.296	.359	.109
F	192210218	HDC-214-CC	2	BROWN	1/4	.278	1.343	.609	.671	.296	.437	.125
F	192210219	HDC-2516-CC	2	BROWN	5/16	.340	1.343	.609	.671	.296	.437	.125
E	192210220	HDC-238-CC	2	BROWN	3/8	.400	1.750	.609	.968	.390	.437	.125
E	192210221	HDC-114-CC	1	GREEN	1/4	.278	1.640	.687	.750	.343	.484	.140
E	192210271	HDC-1516-CC	1	GREEN	5/16	.340	1.640	.687	.750	.343	.484	.140
E	192210272	HDC-138-CC	1	GREEN	3/8	.400	1.890	.687	1.000	.453	.484	.140
E	192210273	HDC-112-CC	1	GREEN	1/2	.520	1.890	.687	1.000	.453	.484	.140
D	192210274	HDC-1014-CC	1/0	PINK	1/4	.278	1.796	.765	.781	.375	.531	.140
D	192210275	HDC-10516-CC	1/0	PINK	5/16	.340	1.796	.765	.781	.375	.531	.140
D	192210276	HDC-1038-CC	1/0	PINK	3/8	.400	2.046	.765	1.031	.453	.531	.140
D	192210277	HDC-1012-CC	1/0	PINK	1/2	.520	2.046	.765	1.031	.453	.531	.140
D	192210278	HDC-2014-CC	2/0	BLACK	1/4	.278	1.953	.828	.828	.375	.578	.140
D	192210105	HDC-20516-CC	2/0	BLACK	5/16	.340	1.953	.828	.828	.375	.578	.140
D	192210106	HDC-2038-CC	2/0	BLACK	3/8	.400	2.203	.828	1.078	.453	.578	.140
D	192210107	HDC-2012-CC	2/0	BLACK	1/2	.520	2.203	.828	1.078	.453	.578	.140
D	192210108	HDC-3014-CC	3/0	ORANGE	1/4	.278	2.093	.906	.843	.375	.625	.140
D	192210109	HDC-30516-CC	3/0	ORANGE	5/16	.340	2.093	.906	.843	.375	.625	.140
D	192210110	HDC-3038-CC	3/0	ORANGE	3/8	.400	2.343	.906	1.093	.453	.625	.140
C	192210355	HDC-3012-CC	3/0	ORANGE	1/2	.520	2.343	.906	1.093	.453	.625	.140
C	192210356	HDC-4014-CC	4/0	PURPLE	1/4	.278	2.250	1.015	.875	.375	.703	.156
C	192210357	HDC-40516-CC	4/0	PURPLE	5/16	.340	2.250	1.015	.875	.375	.705	.156
C	192210358	HDC-4038-CC	4/0	PURPLE	3/8	.400	2.500	1.015	1.125	.453	.703	.156
C	192210359	HDC-4012-CC	4/0	PURPLE	1/2	.520	2.500	1.015	1.125	.453	.703	.156
B	192210360	HDC-25038-CC	250MCM	YELLOW	3/8	.400	2.609	1.140	1.140	.500	.781	.187
B	192210361	HDC-25012-CC	250MCM	YELLOW	1/2	.520	2.609	1.140	1.140	.500	.781	.187
B	192210362	HDC-30038-CC	300MCM	WHITE	3/8	.400	2.734	1.218	1.140	.500	.843	.187
B	192210363	HDC-30012-CC	300MCM	WHITE	1/2	.520	2.796	1.218	1.203	.546	.843	.187
B	192210364	HDC-30058-CC	300MCM	WHITE	5/8	.660	2.796	1.218	1.203	.546	.843	.187
B	192210365	HDC-35012-CC	350MCM	RED	1/2	.520	2.984	1.312	1.250	.546	.906	.203
B	192210366	HDC-35058-CC	350MCM	RED	5/8	.660	2.984	1.312	1.250	.546	.906	.203
B	192210367	HDC-40012-CC	400MCM	BLUE	1/2	.520	3.093	1.578	1.281	.546	.968	.218
B	192210368	HDC-40058-CC	400MCM	BLUE	5/8	.660	3.093	1.578	1.281	.546	.968	.218
B	192210369	HDC-50012-CC	500MCM	BROWN	1/2	.520	3.453	1.578	1.296	.546	1.093	.250
B	192210370	HDC-50058-CC	500MCM	BROWN	5/8	.660	3.453	1.578	1.406	.546	1.093	.250
A												
A												
A												

- NOTES:
1. MATERIAL: COPPER
2. PLATING: TIN
3. OTHER STUD SIZES MAY BE AVAILABLE, PLEASE CONSULT FACTORY.
4. UL, CSA, AND WIRE GAUGE PRINTED ON TERMINAL.
5. ALL DIMENSIONS ARE REFERENCE ONLY.

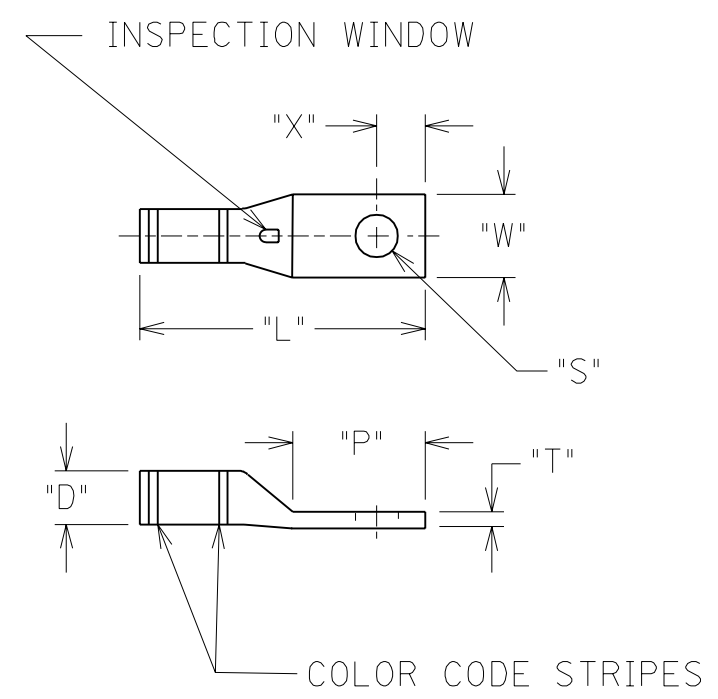

CUSTOMER DRAWING

A	RELEASE CUSTOMER DRAWING 05/11 ETC2000-0227 JH
LTR.	REVISIONS

DIMENSIONS SHOWN (METRIC) INCH		REVISE ONLY ON CAD SYSTEM																			
UNLESS OTHERWISE SPECIFIED TOLERANCES: ANGULAR ± 1/2°		TITLE HEAVY DUTY COMPRESSION SITE HOLE TERMINALS STANDARD BARREL ONE HOLE																			
<table border="1"> <thead> <tr> <th></th> <th>INCH</th> <th>METRIC</th> </tr> </thead> <tbody> <tr> <td>3 PLACE</td> <td>± ---</td> <td>± ---</td> </tr> <tr> <td>2 PLACE</td> <td>± ---</td> <td>± ---</td> </tr> <tr> <td>1 PLACE</td> <td>± ---</td> <td>± ---</td> </tr> </tbody> </table>			INCH	METRIC	3 PLACE	± ---	± ---	2 PLACE	± ---	± ---	1 PLACE	± ---	± ---	<table border="1"> <tr> <td>moLEX ETC INC.</td> <td>SHEET NO.</td> <td>DATE</td> </tr> <tr> <td>PINELLAS PARK, FLA. 33781 U.S.A.</td> <td></td> <td>94/02/14</td> </tr> </table>		moLEX ETC INC.	SHEET NO.	DATE	PINELLAS PARK, FLA. 33781 U.S.A.		94/02/14
	INCH	METRIC																			
3 PLACE	± ---	± ---																			
2 PLACE	± ---	± ---																			
1 PLACE	± ---	± ---																			
moLEX ETC INC.	SHEET NO.	DATE																			
PINELLAS PARK, FLA. 33781 U.S.A.		94/02/14																			
DRAFT WHERE APPLICABLE MUST REMAIN WITHIN DIMENSIONS		PART NO. SEE CHART																			
DRWG. BY JH		DRWG. NO. SD-19221-003																			
APP'D. BY RWD		FILE NAME 19221003 DGN																			
CHK'D. BY RWD		THIS DRAWING CONTAINS INFORMATION THAT IS PROPRIETARY TO MOLEX-ETC INC. AND SHOULD NOT BE USED WITHOUT WRITTEN PERMISSION.																			
SCALE NO:NE		DIV. B																			