

### Industrial 16mm Size Conductive Plastic Precision Rotary Sensor

#### Features

- Robust Construction
- 2 Million Cycle Life
- 2% Precision Linearity
- Water Resistant (IP54, IP67)
- Wide Temperature Range
- Solder Lug, Faston, PC Terminal
- Continuous Rotation Available
- RoHS Compliant



### Electrical and Mechanical Specifications

#### Resistance Range

1 K through 500 K ohms, linear  
Consult CTS for audio taper

#### Resistance Tolerance

± 10%, ± 20%

#### Power Rating

0.25 watts @ 55°C

#### Dielectric Strength

750 VDC for 1 minute

#### Maximum Operating Voltage

500 VDC

#### Insulation Resistance

1000 Megohms minimum @ 500 VDC

#### Angle of Rotation

250°, 300°, 360°

(Refer to Resistance Tapers for detail)

#### Rotational Torque

20 – 180 gf-cm

#### Stop Strength

9 kgf-cm minimum

#### Push-Pull Strength of Shaft

13.6 kg for 10 seconds

#### Mounting Information

Bushing Mount

#### Rotational Life

2 M cycles

#### Linearity

± 2%

#### Temperature

Operating: -40°C to 125°C

Storage: -55°C to 150°C

#### Solder Heat Resistance

350°C for 5 seconds

#### Ingress Protection Rating

IP54, IP67

#### Vibration

15G, 10 to 2000 Hz

## 282S Metal Shaft, Bushing Mount, Solder Lug (Faston) Terminal Formed to Rear

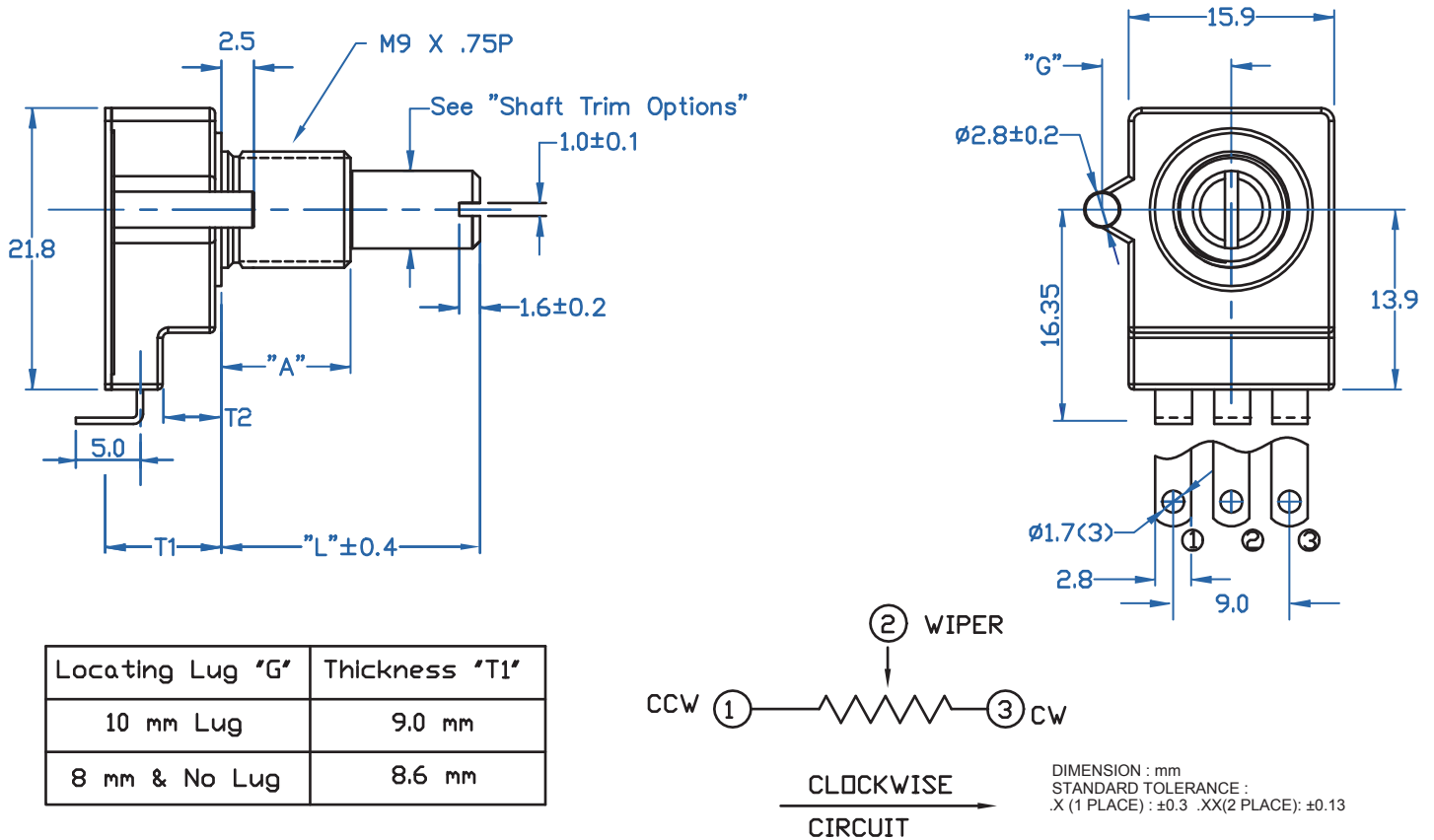

## 282U Metal Shaft, Bushing Mount, PC Terminal Formed to Front

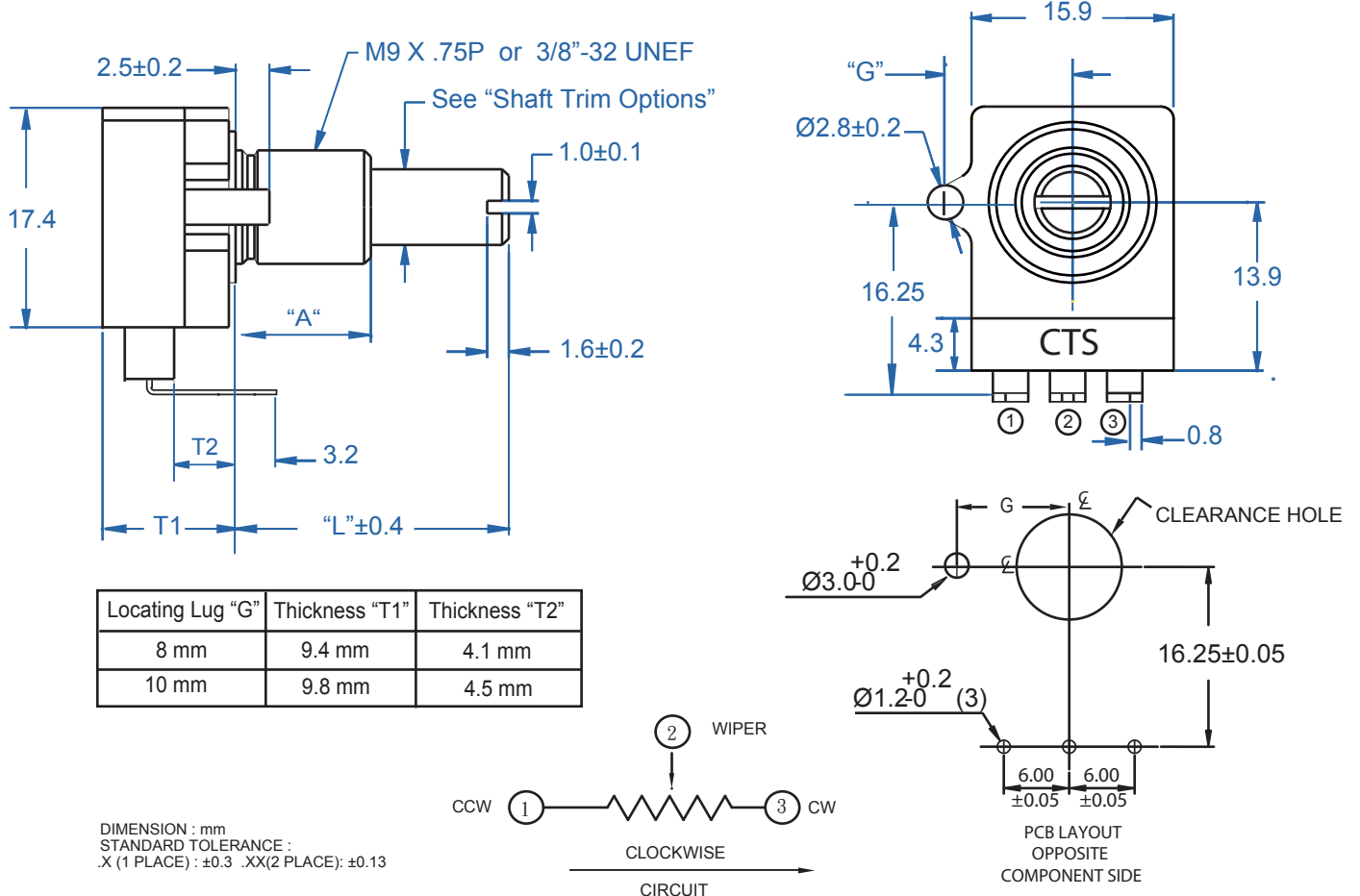

# 282T Metal Shaft, Bushing Mount, Solder Lug (Faston) Terminal

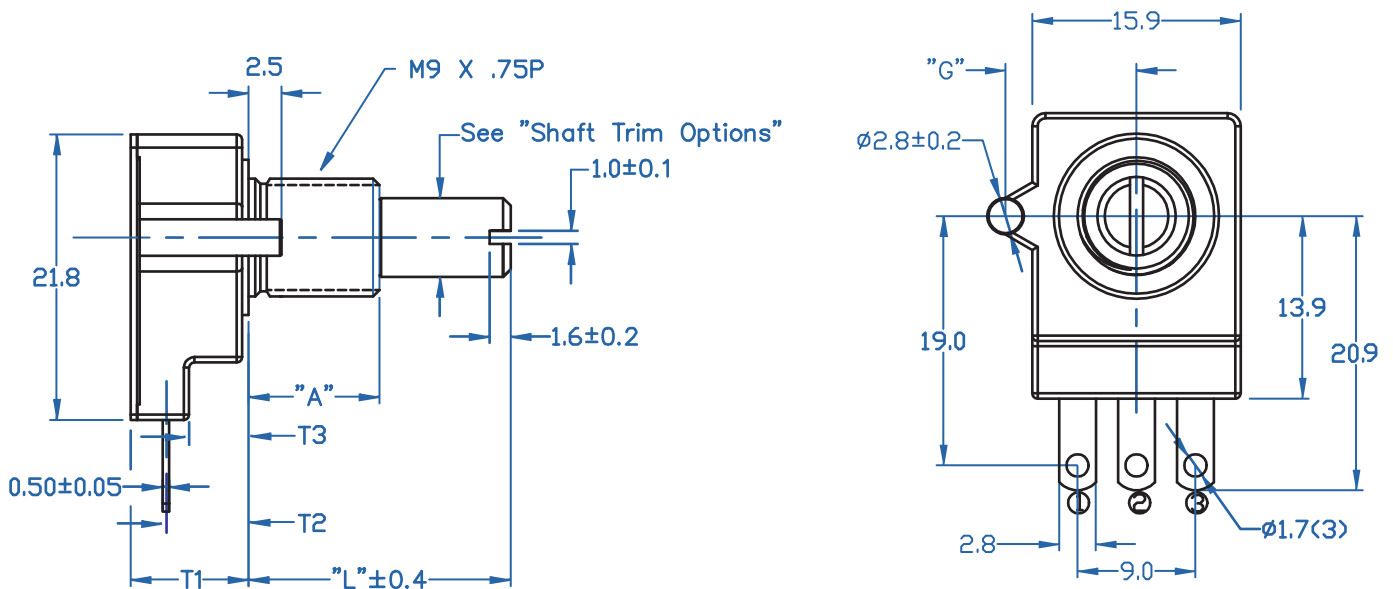

Locating Lug "G"	Thickness "T1"
10 mm Lug	9.0 mm
8 mm & No Lug	8.6 mm

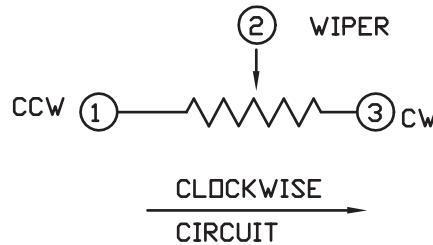

DIMENSION : mm  
STANDARD TOLERANCE :  
.X (1 PLACE) : ±0.3 .XX(2 PLACE) : ±0.13

## Shaft Trim Options

ROUND

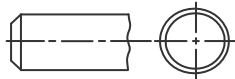

Shaft Trim	Diameter
R	.236" (6.00 mm)
O	.250" (6.35 mm)

FLATTED

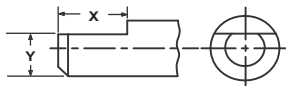

Shaft Trim	Diameter	X	Y
F	.236" (6.00 mm)	.375" (9.52 mm)	.156" (3.96 mm)
L	.250" (6.35 mm)	.440" (11.18 mm)	.217" (5.50 mm)

SD SLOT



Shaft Trim	Diameter	X	Y
S	.236" (6.00 mm)	.063" (1.6mm)	.039" (1.0mm)
D	.250" (6.35 mm)	.063" (1.6mm)	.039" (1.0mm)

KNURLED & SLOTTED

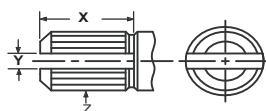

Shaft Trim	Diameter	X	Y	Z
K	.236" (6.00 mm)	.344" (8.74 mm)	.063" (1.60 mm)	24 Teeth

# Resistance Tapers

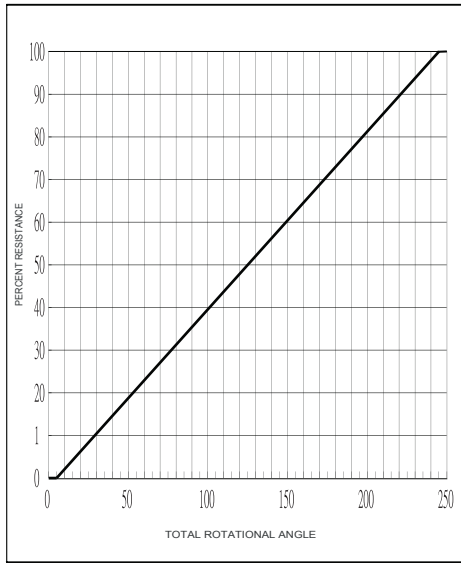

TOTAL ROTATIONAL ANGLE: 250

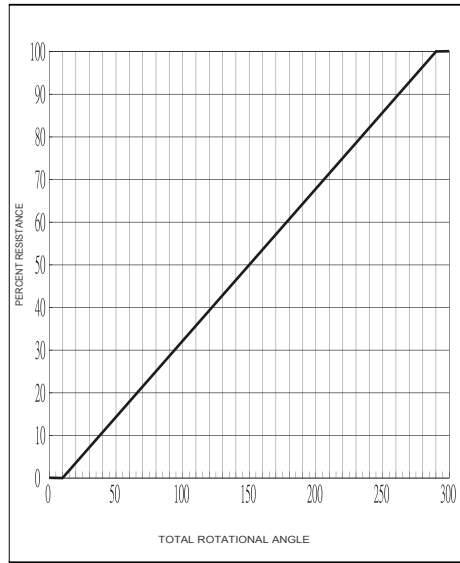

TOTAL ROTATIONAL ANGLE: 300°

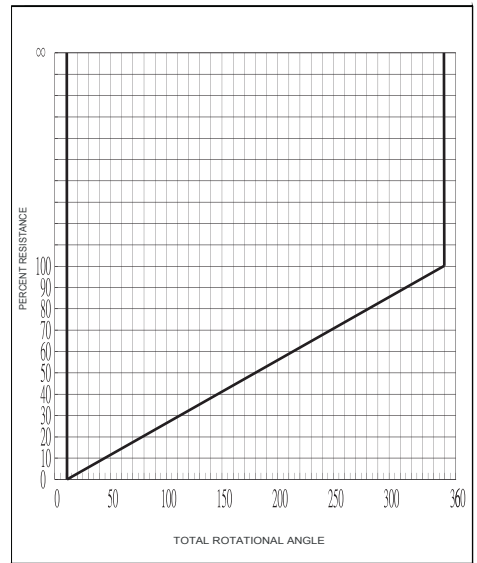

TOTAL ROTATIONAL ANGLE: 360°

# Ordering Information

**282 T A A R 103 A 2 5 B 1**

**TERMINAL STYLE**

T- Solder Lug(Faston)  
S- Solder Lug Formed to Rear  
U- PC Terminals Formed to Front

**SHAFT LENGTH "L"**

Examples:

mm	inch
A - 10 mm	1 - .625"
B - 15 mm	2 - .750"
C - 20 mm	3 - .875"
D - 25 mm	4 - 1.000"
E - 30 mm	5 - 1.125"

Note:  
Incremental length : 5mm or .125"

**RESISTANCE CODE EXAMPLES**

CODE	RESISTANCE
102	1K
103	10K
503	50K
104	100K
504	500K

**LINEARITY**

2 - ± 2%

**LOCATING LUG "G"**

1 - Left, 10mm  
2 - Left, 8mm  
3 - No Lug

**BUSHING MOUNT "A"**

Bushing Length	
mm	inch
A - 5.0 mm	2 - .250"
B - 7.5 mm	3 - .375"
C - 10.0 mm	4 - .500"

Notes:  
Incremental Length : 2.5mm or .125"  
Bushing Dia. & Thread:  
M9 X .75P (metric)  
3/8" - 32 UNEF (imperial)

**SHAFT TRIM OPTIONS**

**Shaft Diameter 6mm (.236")**

R - Round  
F - Flatted .375" X .156"  
K - Knurled 24 Teeth  
S - SD Slot .039"W X .063" D

**Shaft Diameter 6.35mm (.250")**

O - Round  
L - Flatted .440" X .217"  
D - SD Slot .039" W X .063" D

**RESIST TOL**

A - ± 10%  
B - ± 20%

**IP Rating**

5 - IP54  
6 - IP67

**ROTATION ANGLE**

	Total	Effective
A -	250°	240°
B -	300°	280°
C -	360°	340

Please consult factory for other mounting options or custom features not listed.

Standard Part - 282T33L502A25A2, 282T33L502A25C2, 282TCBS103A25B1  
282T33L502A26A2, 282T33L502A26C2, 282TCBS103A26B1