

SPECIFICATIONS:

1. MATERIAL:
 - (1) BODY: PA66 (UL 94V-0).
 - (2) COVER: PBT (UL 94V-0).
 - (3) LONG TERMINAL: BRASS.
 - (4) SHORT TERMINAL: BRASS.
2. ELECTRICAL RATING: 300V, 15A.
3. DIELECTRIC WITHSTAND: AC 2500V FOR 1 MINUTE.
4. BREAKDOWN VOLTAGE: 4000V.
5. INSULATION RESISTANCE: DC 1000V, 1000 MEGOHMS.
6. OPERATING TEMPERATURE: -40°C TO +105°C.
7. NUMBER OF CIRCUIT POSITIONS AVAILABLE= 4 THROUGH 48, EVEN NUMBERED CIRCUIT SIZES ONLY.
8. ALL COMPONENTS ARE ROHS COMPLIANT.

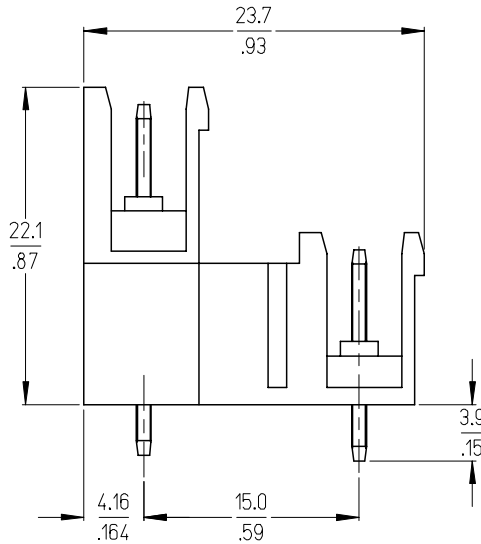
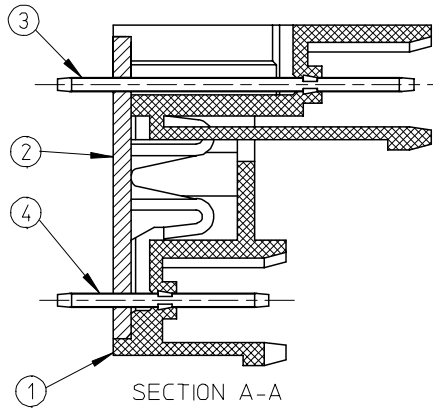
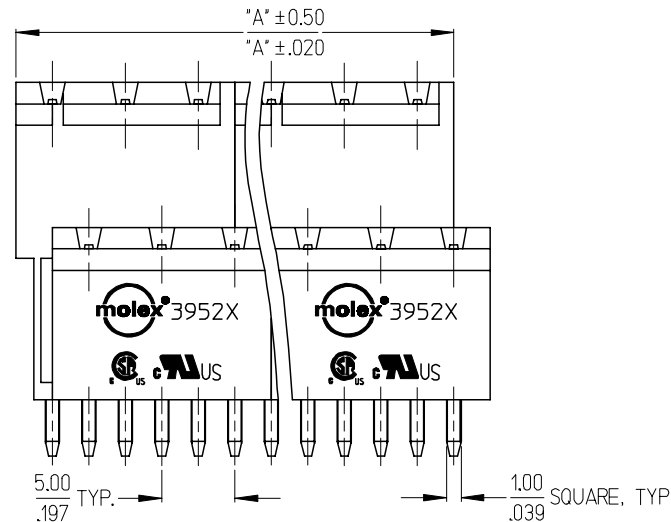
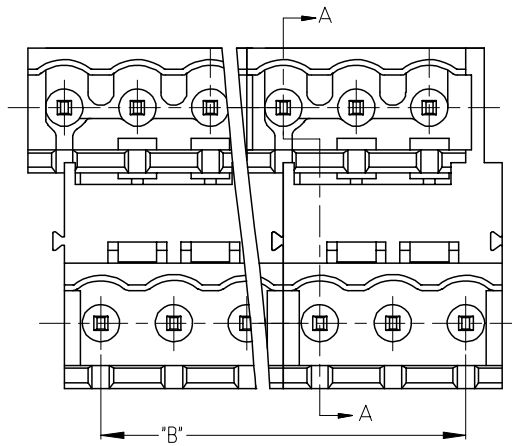

INITIAL RELEASE EC NO: ETC2007-0020 DRWN: CYORK 2006/07/25 CHKD: JPWLICKI 2006/07/25 APPR: JPWLICKI 2006/07/26	QUALITY SYMBOLS ▽=0 ▽=0	GENERAL TOLERANCES (UNLESS SPECIFIED)		DIMENSION STYLE		SCALE	DESIGN UNITS	THIRD ANGLE PROJECTION
				MM/IN		3:1	INCH	
				DRAWN BY DATE		TITLE		
				CHECKED BY DATE		MOLEX INCORPORATED		
		APPROVED BY DATE		MATERIAL NO.		DOCUMENT NO.		SHEET NO.
		ANGULAR ± 2 °		SEE SHT. 2		SD-39528-003		
		DRAFT WHERE APPLICABLE MUST REMAIN WITHIN DIMENSIONS		SIZE B		THIS DRAWING CONTAINS INFORMATION THAT IS PROPRIETARY TO MOLEX INCORPORATED AND SHOULD NOT BE USED WITHOUT WRITTEN PERMISSION		

F
E
D
C
B
A

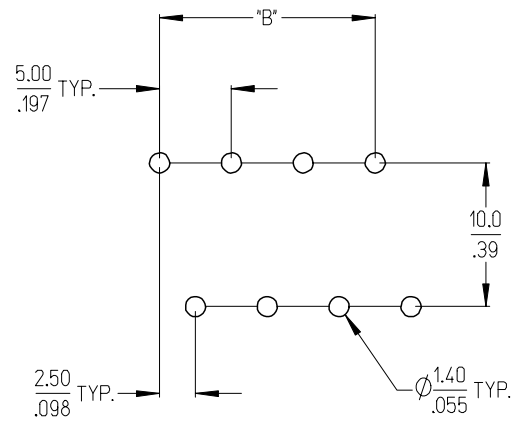

RECOMMENDED PCB LAYOUT

Circuit size	Material Numbers				Dimensional Information			
	Black		Green		Dim. A		Dim B	
	100% Tin	30 u" Gold	100% Tin	30 u" Gold	mm	inch	mm	inch
4	395282004	395282504	395287004	395287504	10.00	0.394	5.00	0.197
6	395282006	395282506	395287006	395287506	15.00	0.591	10.00	0.394
8	395282008	395282508	395287008	395287508	20.00	0.787	15.00	0.591
10	395282010	395282510	395287010	395287510	25.00	0.984	20.00	0.787
12	395282012	395282512	395287012	395287512	30.00	1.181	25.00	0.984
14	395282014	395282514	395287014	395287514	35.00	1.378	30.00	1.181
16	395282016	395282516	395287016	395287516	40.00	1.575	35.00	1.378
18	395282018	395282518	395287018	395287518	45.00	1.772	40.00	1.575
20	395282020	395282520	395287020	395287520	50.00	1.969	45.00	1.772
22	395282022	395282522	395287022	395287522	55.00	2.165	50.00	1.969
24	395282024	395282524	395287024	395287524	60.00	2.362	55.00	2.165
26	395282026	395282526	395287026	395287526	65.00	2.559	60.00	2.362
28	395282028	395282528	395287028	395287528	70.00	2.756	65.00	2.559
30	395282030	395282530	395287030	395287530	75.00	2.953	70.00	2.756
32	395282032	395282532	395287032	395287532	80.00	3.150	75.00	2.953
34	395282034	395282534	395287034	395287534	85.00	3.346	80.00	3.150
36	395282036	395282536	395287036	395287536	90.00	3.543	85.00	3.346
38	395282038	395282538	395287038	395287538	95.00	3.740	90.00	3.543
40	395282040	395282540	395287040	395287540	100.00	3.937	95.00	3.740
42	395282042	395282542	395287042	395287542	105.00	4.134	100.00	3.937
44	395282044	395282544	395287044	395287544	110.00	4.331	105.00	4.134
46	395282046	395282546	395287046	395287546	115.00	4.528	110.00	4.331
48	395282048	395282548	395287048	395287548	120.00	4.724	115.00	4.528

SEE SHEET 1 EC NO: ETC2007-0020 DRWN: CYORK 2006/07/25 CHKD: JPWLICKI 2006/07/25 APPR: JPWLICKI 2006/07/26	QUALITY SYMBOLS ▽=0 ▽=0	GENERAL TOLERANCES (UNLESS SPECIFIED)		DIMENSION STYLE MM/IN	SCALE 3:1	DESIGN UNITS INCH	THIRD ANGLE PROJECTION
		4 PLACES ± --- ± --- 3 PLACES ± --- ± .005 2 PLACES ± 0.13 ± .01 1 PLACE ± 0.3 ± --- ANGULAR ± 2 °	DRAWN BY C. YORK 2006/07/24	DATE 2006/07/24	TITLE 5.0MM, EURO DUAL HEADER, VERTICAL, OPEN END, STACKABLE		
		DRAFT WHERE APPLICABLE MUST REMAIN WITHIN DIMENSIONS	CHECKED BY J. PAWLICKI 2006/07/24	DATE 2006/07/24	MOLEX INCORPORATED		
		MATERIAL NO. SEE CHART	APPROVED BY J. PAWLICKI 2006/07/24	DATE 2006/07/24	DOCUMENT NO. SD-39528-003	SHEET NO. 2 OF 2	