

THIS DRAWING IS UNPUBLISHED. RELEASED FOR PUBLICATION .19 .  
 © COPYRIGHT 19 BY AMP INCORPORATED. ALL RIGHTS RESERVED.

LOC	DIST	REVISIONS			
P	LTR	DESCRIPTION	DATE	DWN	APVD
AJ	16	D	REV PER 0U20-0410-00	13SEP00	MO KW

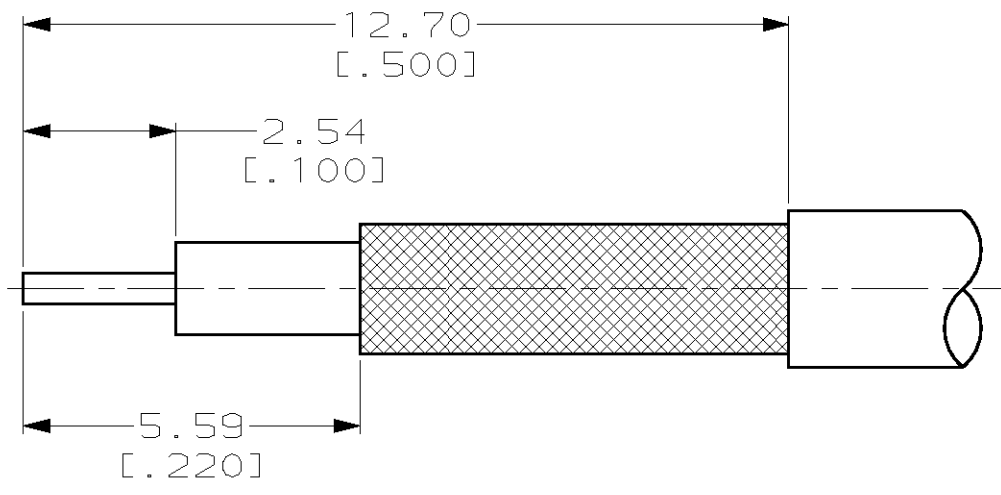

RECOMMENDED STRIP LENGTHS

- 1 CRIMP CONTACT USING MIL HAND TOOL M22520/2-01 WITH DANIELS POSITIONER K1041, SET AT POSITION NUMBER 4.
- 2 CRIMP CABLE BRAID USING MIL HAND TOOL M22520/5-02 WITH DANIELS DIE SET HX4-1607 (.128 INCH HEX) OR USE AMP PRO-CRIMPER II WITH DIE SET NUMBER 58489-1.
- 3 CRIMP CABLE BRAID USING MIL HAND TOOL M22520/5-01 WITH DANIELS DIE SET Y138 (.151 INCH HEX) OR USE AMP PRO-CRIMPER II WITH DIE SET NUMBER 58425-3.
- 4 SEE DRAWING 414948-1 FOR INFORMATION SPECIFIC TO THIS PART NUMBER.

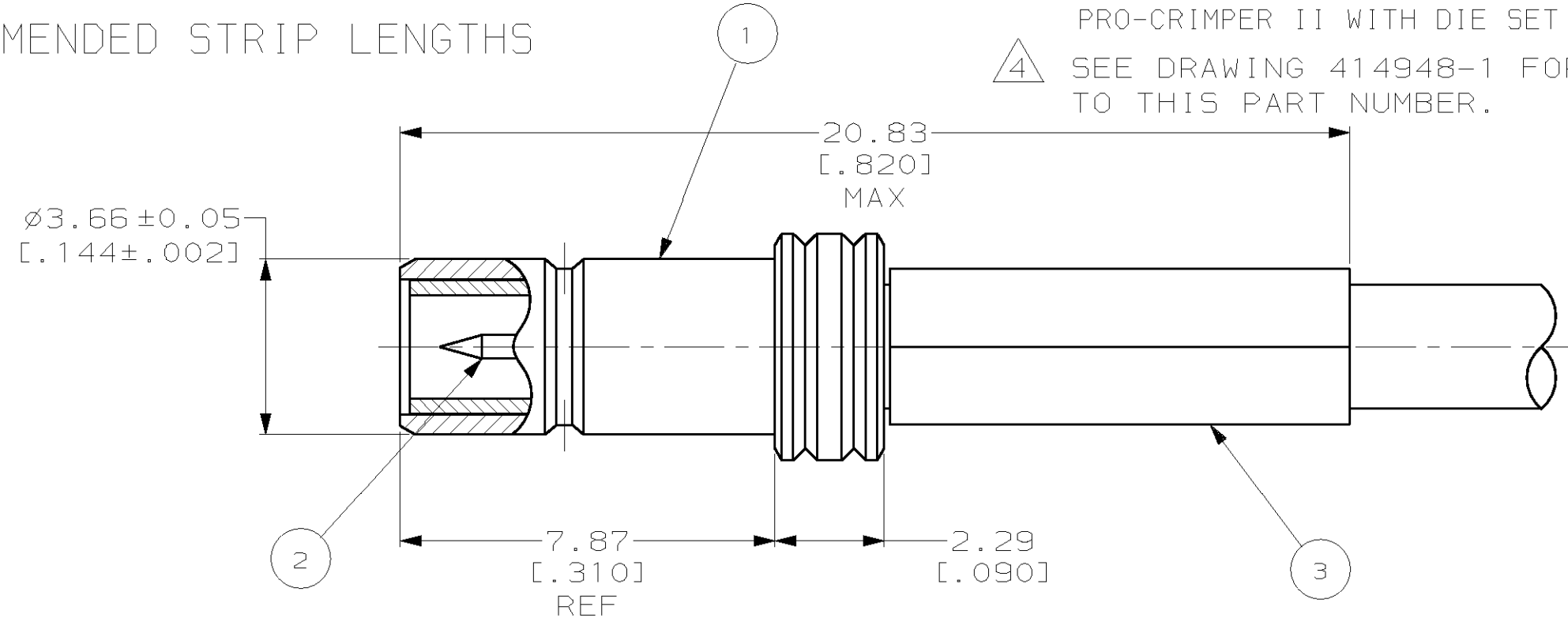

3	1	RD-188, & -316	1-413889-4	414187-2	414960-1	414948-3
2	1	RG-179, & -187/U	1-413889-3	414187-4	414960-1	414948-2
4	-	-	-	-	-	414948-1
BRAID CRIMP	CONTACT CRIMP	CABLE	3 FERRULE QTY=1	2 CONTACT QTY=1	1 JACK ASSY QTY=1	PART NUMBER

THIS DRAWING IS A CONTROLLED DOCUMENT.

DWN	B. MOYER	090CT96	<b>AMP</b> AMP Incorporated Harrisburg, PA 17105-3608		
CHK	J. CABARLO	100CT96			
APVD	J. CABARLO	100CT96			
NAME	CABLE JACK, STRAIGHT, 50 OHM, SMB				
DIMENSIONS:	TOLERANCES UNLESS OTHERWISE SPECIFIED:		SIZE	CAGE CODE	DRAWING NO
mm [INCHES]	0 PLC ±-		A3	00779	C-414948
	1 PLC ±-		WEIGHT	SCALE 8:1 SHEET 1 OF 1 REV D	
	2 PLC ±0.25 [.010]		CUSTOMER DRAWING		
	3 PLC ±-				
	4 PLC ±-				
	ANGLES ±-				
MATERIAL	FINISH				