

DATE CODE, MOLEX, PART NUMBER

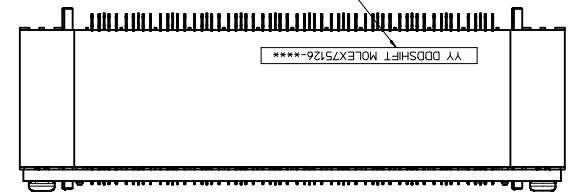

NOTES:

1. MATERIALS FOR INTERPOSER AND HIGH SPEED DOCKING CONNECTOR:  
HOUSING: LIQUID CRYSTAL POLYMER (LCP), GLASS FILLED, 94 V-0.  
WAFER: LIQUID CRYSTAL POLYMER (LCP), 94 V-0, BLACK.  
CONTACTS: COPPER ALLOY  
HEXAGONAL THREADED INSERT: CARBON STEEL  
MACHINE SCREW: CARBON STEEL
2. THIS ASSEMBLY CONFORMS TO PRODUCT SPECIFICATION PS-75018-001.
3. THIS ASSEMBLY TO BE PACKAGED PER PK-75126-001.
4. THIS ASSEMBLY CONFORMS TO CLASS C COSMETIC SPEC. PS-45499-002.
5. RECOMMENDED DRILL SIZE: 0.66±0.03 TO YIELD FINISHED PLATED THROUGH HOLE OF 0.55±0.05.
6. USE APPLICATION TOOL 62202XXXX WHEN INSERTING INTO PCB.
7. RECOMMENDED SCREW LENGTH TO MOUNT TO PCB TO BE 5mm, PLUS MOTHER BOARD THCKNESS MIN. TORQUE REQUIREMENT: 2 IN-LBS MIN. 5 IN-LBS MAX.

CONVERT TO LEAD-FREE EC NO: UCP2013-1884 2012/11/12 DRAWN BY: BARRA CHKD: JJJ APPR: MILLER 2013/01/04	QUALITY SYMBOLS	GENERAL TOLERANCES (UNLESS SPECIFIED)	DIMENSION STYLE	SCALE	DESIGN UNITS	THIRD ANGLE PROJECTION
	▽=0	mm INCH	MM/IN	2:1	METRIC	☉
	▽=0	4 PLACES ± --- ± --- 3 PLACES ± --- ± .010 2 PLACES ± 0.25 ± --- 1 PLACE ± --- ± --- 0 PLACE ± ±	DRAWN BY: KSTILES DATE: 7/16/2003 CHECKED BY: DATE: 7/16/2003 APPROVED BY: DATE: 7/16/2003 MBANKIS	TITLE	PLATEAU HS DOCK 8.74 CL INTERPOSER SALES DRAWING	
	▽=0	ANGULAR ±1/2° DRAFT WHERE APPLICABLE MUST REMAIN WITHIN DIMENSIONS	SEE TABLE	DOCUMENT NO.	SD-75126-002 SHEET NO. 1 OF 3	
MATERIAL NO. SD-75126-002 SIZE D THIS DRAWING CONTAINS INFORMATION THAT IS PROPRIETARY TO MOLEX INCORPORATED AND SHOULD NOT BE USED WITHOUT WRITTEN PERMISSION						

CIRCUIT SIZE	ITEM NUMBER	PLATEAU HS DOCK™	DIM 'A'	DIM 'B'	DIM 'C'	DIM 'D'	DIM 'E'	DIM 'F'	DIM 'G'	PLATING FINISH	CONNECTOR WAFER TYPE
108			90.50 3.563	81.50 3.209	89.00 3.504	75.62 2.977	99.40 3.913	71.00±0.08 2.795±.003	66.00±0.08 2.598±.003	FINISH 1	WELDED
144	75126-2001	75018-3023	111.50 4.390	102.50 4.035	110.00 4.331	96.62 3.804	120.40 4.740	92.00±0.08 3.622±.003	87.00±0.08 3.425±.003		
144	75126-2101	75018-3123	111.50 4.390	102.50 4.035	110.00 4.331	96.62 3.804	120.40 4.740	92.00±0.08 3.622±.003	87.00±0.08 3.425±.003	FINISH 2	
144	75126-4001	75018-3123	111.50 4.390	102.50 4.035	110.00 4.331	96.62 3.804	120.40 4.740	92.00±0.08 3.622±.003	87.00±0.08 3.425±.003		
144	75126-8101	75018-8123	111.50 4.390	102.50 4.035	110.00 4.331	96.62 3.804	120.40 4.740	92.00±0.08 3.622±.003	87.00±0.08 3.425±.003	FINISH 3	

1. PLATING FINISH:

FINISH 1: (PREVIOUSLY TIN-LEAD)

CONTACT INTERFACE

0.76 MICROMETERS/30 MICROINCHES MINIMUM SELECT GOLD  
NICKEL UNDERPLATE OVERALL

COMPLIANT INTERFACE

0.76 MICROMETERS/30 MICROINCHES MINIMUM SELECT MATTE-TIN OVER  
NICKEL UNDERPLATE OVERALL

HOUSING

0.10 MICROMETERS/4 MICROINCHES MAXIMUM GOLD OVER  
3.81 MICROMETERS/150 MICROINCHES MINIMUM NICKEL OVER  
COPPER UNDERPLATE OVERALL

FINISH 2:

CONTACT INTERFACE

0.76 MICROMETERS/30 MICROINCHES MINIMUM SELECT GOLD  
NICKEL UNDERPLATE OVERALL

COMPLIANT INTERFACE

0.76 MICROMETERS/30 MICROINCHES MINIMUM SELECT MATTE-TIN OVER  
NICKEL UNDERPLATE OVERALL

HOUSING

0.10 MICROMETERS/4 MICROINCHES MAXIMUM GOLD OVER  
3.81 MICROMETERS/150 MICROINCHES MINIMUM NICKEL OVER  
COPPER UNDERPLATE OVERALL

FINISH 3:

CONTACT INTERFACE

0.76 MICROMETERS/30 MICROINCHES MINIMUM SELECT GOLD  
NICKEL UNDERPLATE OVERALL

COMPLIANT INTERFACE

0.76 MICROMETERS/30 MICROINCHES MINIMUM SELECT MATTE-TIN OVER  
NICKEL UNDERPLATE OVERALL

HOUSING

3.81 MICROMETERS/150 MICROINCHES MINIMUM NICKEL OVER  
COPPER UNDERPLATE OVERALL

SEE SHEET 1 EEC NO: UCP2013-1884 DRAWN BY: J. BARRA CHKD: J. BARRA APPR: MILLER 2012/11/12 2013/01/04	QUALITY SYMBOLS	GENERAL TOLERANCES (UNLESS SPECIFIED)	DIMENSION STYLE	SCALE	DESIGN UNITS	THIRD ANGLE PROJECTION
	▽=0	4 PLACES ±.010	MM/IN	2:1	METRIC	
	▽=0	3 PLACES ±.025				
	▽=0	2 PLACES ±.050				
		ANGULAR ±1/2°	DRAWN BY: KSTILES	DATE: 7/16/2003	TITLE: PLATEAU HS DOCK 8.74 CL INTERPOSER SALES DRAWING	
		DRAFT WHERE APPLICABLE MUST REMAIN WITHIN DIMENSIONS	CHECKED BY: DSCHMIDG	DATE: 7/16/2003	molex	
			APPROVED BY: MBANKIS	DATE: 7/16/2003	DOCUMENT NO. SD-75126-002	
			MATERIAL NO.	DATE: 7/16/2003	SHEET NO. 2 OF 3	
			SIZE: D		THIS DRAWING CONTAINS INFORMATION THAT IS PROPRIETARY TO MOLEX INCORPORATED AND SHOULD NOT BE USED WITHOUT WRITTEN PERMISSION	

# KEEP OUT AREA FOR STAND-OFFS

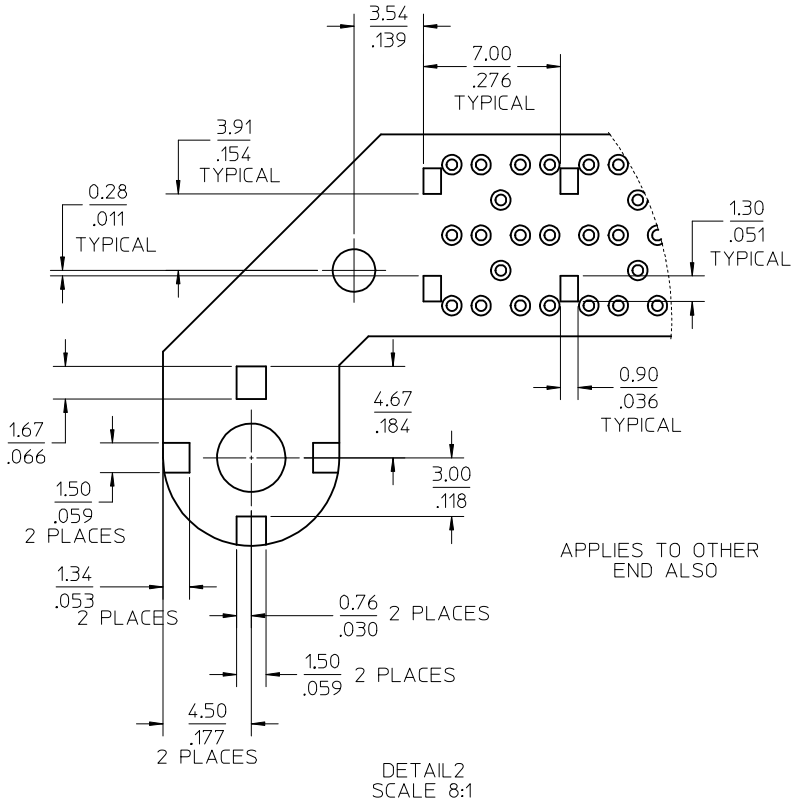

DETAIL2  
SCALE 8:1

NOTE: THE DIMENSIONS DEFINING THE LOCATION AND SIZE OF THE KEEP OUT AREAS DO NOT HAVE TOLERANCES. AT A MINIMUM THE POWER PLANE MUST NOT COME INSIDE THE AREAS DEFINED BY THESE DIMENSIONS.

APPLIES TO OTHER END ALSO

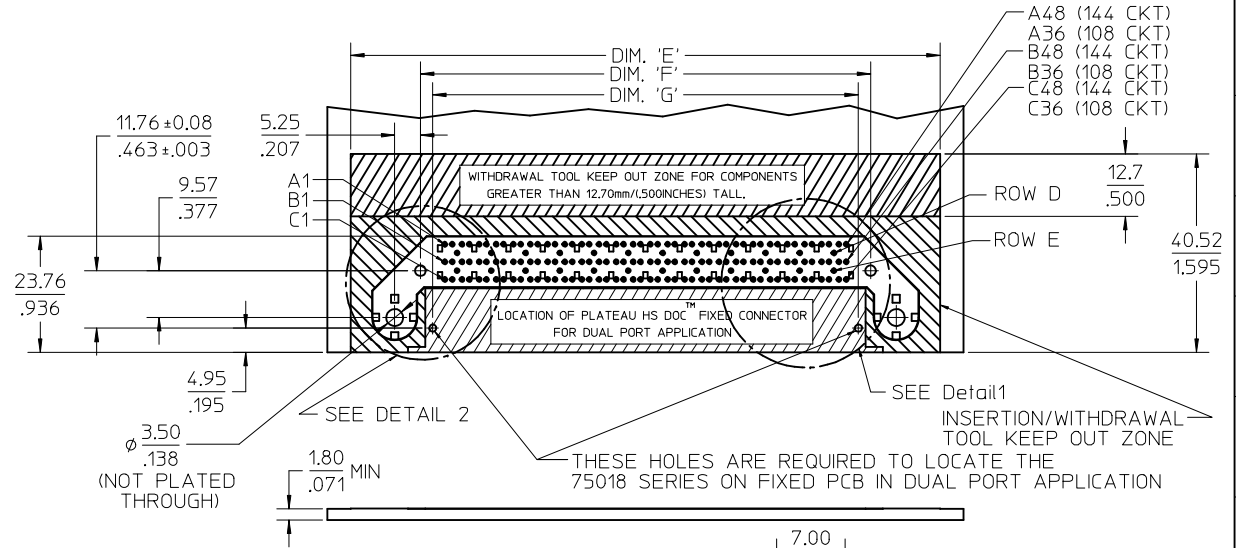

φ 3.50  
.138  
(NOT PLATED THROUGH)

SEE DETAIL 2

THESE HOLES ARE REQUIRED TO LOCATE THE 75018 SERIES ON FIXED PCB IN DUAL PORT APPLICATION

SEE Detail1  
INSERTION/WITHDRAWAL TOOL KEEP OUT ZONE

CIRCUIT DESIGNATION FOR HIGH SPEED DOCKING INTERPOSER CONNECTOR ASSEMBLY:

POWER CIRCUITS (15 AMPS PER INDICATED LINE):  
A2-A1: POWER/RETURN,  
A4-A3: POWER/RETURN,  
C2-C1: POWER/RETURN

ALL REMAINING ROWS ARE SUITABLE FOR DIFFERENTIAL PAIRS  
CURRENT CAPACITY: 300ma

GROUND CIRCUITS: ROWS D & E

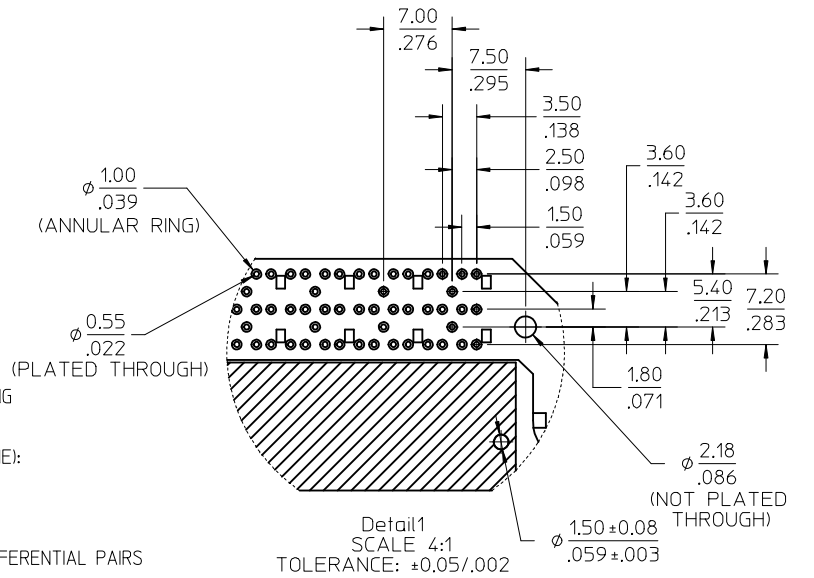

Detail1  
SCALE 4:1

TOLERANCE: ±0.05/1.002

SEE SHEET 1 IEC NO: UCP2013-1884 DRAWN: TIBARRA 2012/11/12 CHKD: APPROV: SMILLER 2013/01/04 DESCRIPTION	QUALITY SYMBOLS	GENERAL TOLERANCES (UNLESS SPECIFIED)	DIMENSION STYLE	SCALE	DESIGN UNITS	THIRD ANGLE PROJECTION
	▽=0	mm INCH	MM/IN	2:1	METRIC	☉
	▽=0	4 PLACES ± .010	DRAWN BY DATE			
	▽=0	3 PLACES ± .025	CHECKED BY DATE			
		1 PLACE ± .010	DSCM1DG 7/16/2003			
		0 PLACE ± .010	APPROVED BY DATE			
			MBANKIS 7/16/2003			
		ANGULAR ±1/2°	MATERIAL NO.			
		DRAFT WHERE APPLICABLE MUST REMAIN WITHIN DIMENSIONS	SEE TABLE			
			DOCUMENT NO.			
			SD-75126-002			
			SHEET NO.			
			3 OF 3			

PLATEAU HS DOCK  
8.74 CL INTERPOSER  
SALES DRAWING

**molex**

SD-75126-002

SHEET NO.  
3 OF 3

THIS DRAWING CONTAINS INFORMATION THAT IS PROPRIETARY TO MOLEX INCORPORATED AND SHOULD NOT BE USED WITHOUT WRITTEN PERMISSION