

MATERIAL NO.	KEY OPTION	TAIL PLATING
76105-0584	LEFT	TIN / LEAD
76105-0585	LEFT	TIN

OBSOLETE

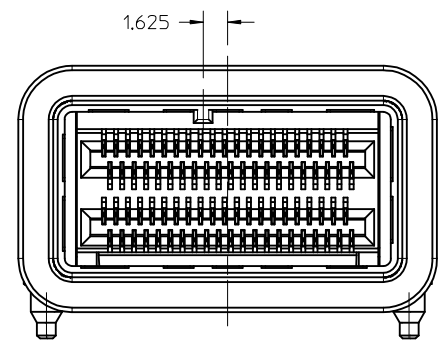
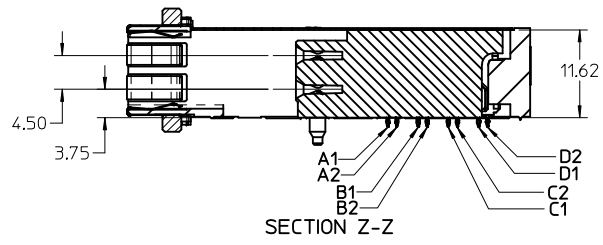
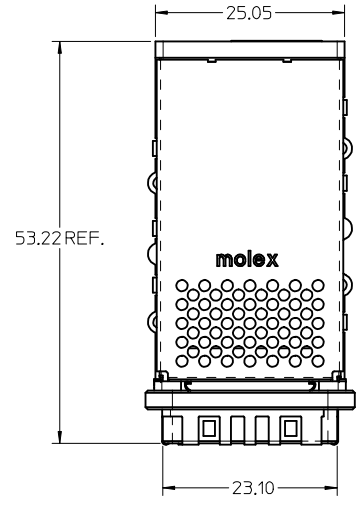
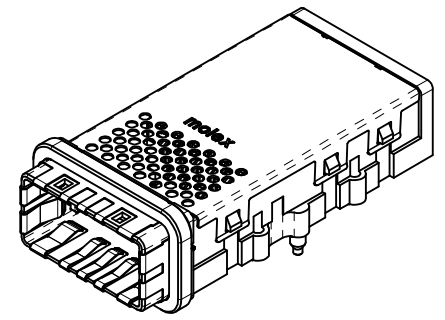

76105-0584
LEFT KEY

(EMI FINGERS REMOVED FOR CLARITY)

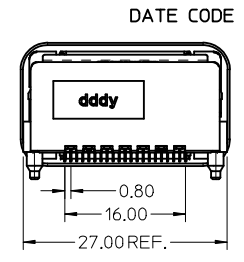
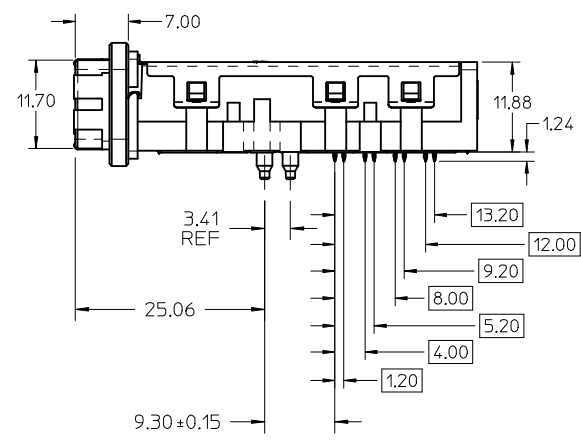
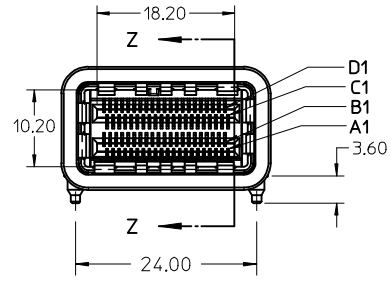

DATE CODE

- NOTES:
- MATERIALS:**
CONNECTOR HOUSING: HIGH TEMPERATURE THERMOPLASTIC
GLASS-FILLED, UL 94V-0
EMI HOUSING: NICKEL PLATED DIE CAST ALLOY
COVER: STAINLESS STEEL ALLOY
EMI GASKET: CONDUCTIVE POLYMER
TERMINALS: COPPER ALLOY
 - PLATING:**
CONTACT AREA: 0.76µm MIN. GOLD OVER 2.54µm MIN. NICKEL
TIN/LEAD TAIL AREA: 0.76µm - 1.52µm TIN/LEAD (90/10)
TIN TAIL AREA: 0.76µm - 1.52µm TIN
OVER 1.27µm MIN NICKEL
 - THIS CONNECTOR IS DESIGNED TO MATE WITH MOLEX CABLE SERIES TBD.
 - PACKAGING SPECIFICATION: TRAY PACK PER PK-76105-001.
 - MOUNTING HARDWARE REQUIRED: M2x0.4 CAP SCREWS (4)
MOUNTING SCREW LENGTH: BOARD THICKNESS + 4mm MAX

UPDATE VIEWS EC NO: UCP2013-0617 DRAWING PRATT 2012/08/28 CHKD: MBANAKI S 2012/08/29 APPR: MBANAKI S 2012/08/30	QUALITY SYMBOLS ▽=0 ▽=0	GENERAL TOLERANCES (UNLESS SPECIFIED)		DIMENSION STYLE MM ONLY		SCALE 2:1	DESIGN UNITS METRIC	THIRD ANGLE PROJECTION	
		4 PLACES ± --- ± --- 3 PLACES ± --- ± --- 2 PLACES ± 0.25 ± --- 1 PLACE ± 0.25 ± ---	mm INCH ± --- ± --- ± 0.25 ± --- ± 0.25 ± ---	DRAWN BY KLANG	DATE 2008/05/05	CHECKED BY KLANG	DATE 2008/05/05	TITLE IPASS PLUS HSC 84 HIGH SPEED CHANNEL 0.8MM I/O	
APPROVED BY MBANAKI S	DATE 2008/05/19	MATERIAL NO. SEE CHART		DOCUMENT NO. SD-76105-584		MOLEX INCORPORATED			
DRAFT WHERE APPLICABLE MUST REMAIN WITHIN DIMENSIONS		SIZE C		THIS DRAWING CONTAINS INFORMATION THAT IS PROPRIETARY TO MOLEX INCORPORATED AND SHOULD NOT BE USED WITHOUT WRITTEN PERMISSION					

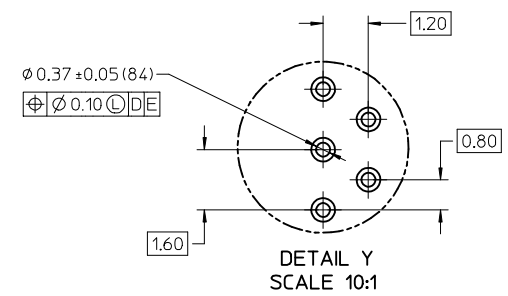
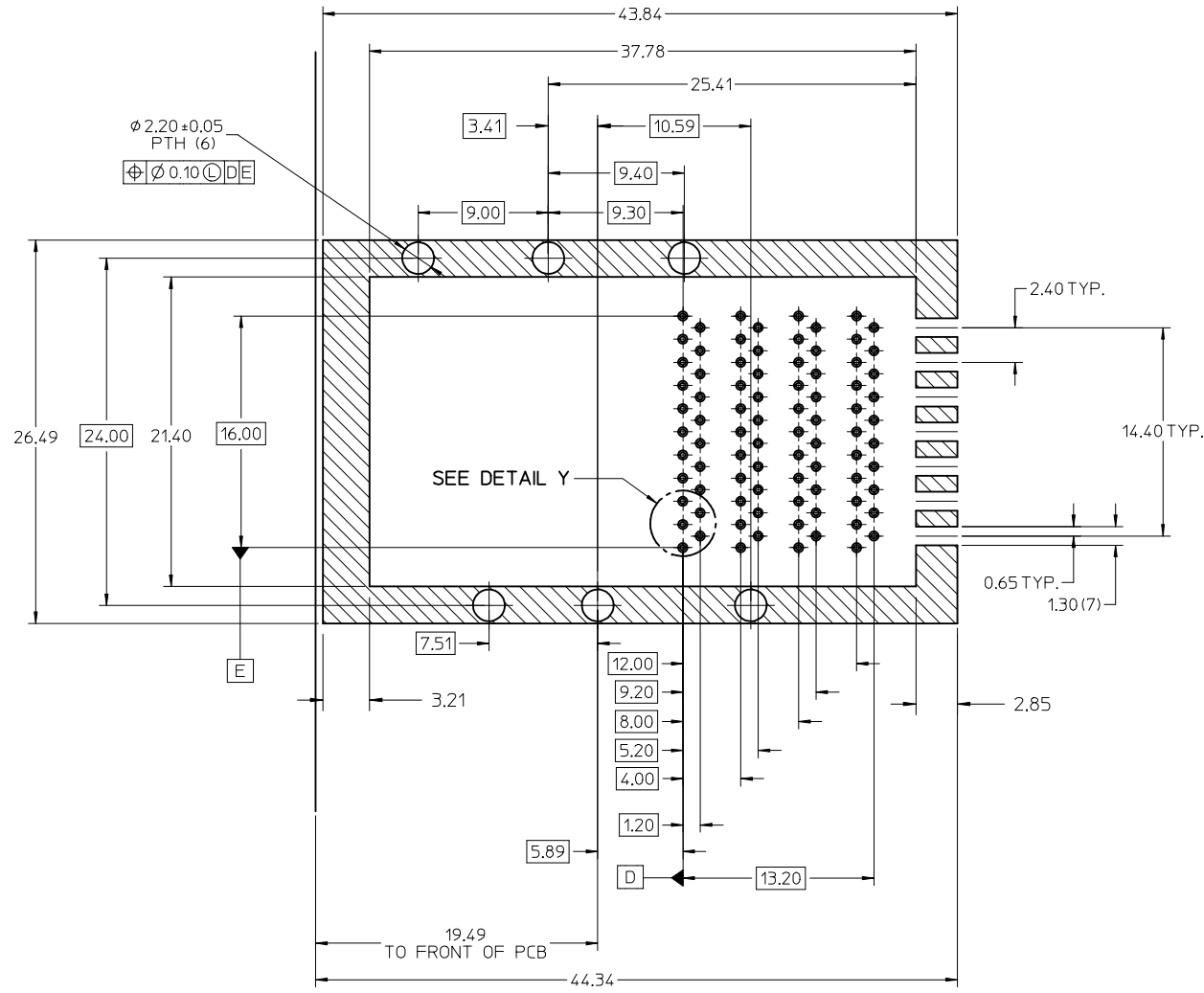

- NOTES:
- CROSS-HATCHED AREA TO BE CONDUCTIVE ON THE PCB.
 - CROSS-HATCHED AREA MUST BE INCORPORATED IN THE FLAT ROCK PRESS-FIT TOOLING.
 - RECOMMENDED DRILL SIZE FOR 0.37 ϕ FINISHED PTH IS 0.48-0.50 mm ϕ (.0189-.0200 in ϕ (#76 DRILL))
 - RECOMMENDED ANNULAR RING AROUND 0.37 ϕ FINISHED PTH IS 0.73 ϕ
 - MINIMUM RECOMMENDED SPACING: 26.50

RECOMMENDED PCB LAYOUT
COMPONENT SIDE SHOWN
PCB THICKNESS: 1.57mm MIN.

SEE SHEET 1 EC NO: UCP2013-0647 DRAWING PRATT 2012/08/28 CHKD: MBANAKI S 2012/08/29 APPR: MBANAKI S 2012/08/30	QUALITY SYMBOLS	GENERAL TOLERANCES (UNLESS SPECIFIED)	DIMENSION STYLE	SCALE	DESIGN UNITS	THIRD ANGLE PROJECTION	
	$\nabla=0$ $\nabla=0$	mm INCH	MM ONLY	4:1	METRIC		
		4 PLACES ± --- ± --- 3 PLACES ± --- ± --- 2 PLACES ± 0.25 ± --- 1 PLACE ± 0.25 ± ---	DRAWN BY DATE KLANG 2008/05/05	TITLE IPASS PLUS HSC 84 HIGH SPEED CHANNEL 0.8MM I/O			
		ANGULAR ±1/2°	CHECKED BY DATE KLANG 2008/05/05	APPROVED BY DATE MBANAKI S 2008/05/19			
	DRAFT WHERE APPLICABLE MUST REMAIN WITHIN DIMENSIONS	MATERIAL NO.	SEE SHEET 1		MOLEX INCORPORATED		
			SIZE C		DOCUMENT NO.	SHEET NO.	
					SD-76105-584	2 OF 4	
			THIS DRAWING CONTAINS INFORMATION THAT IS PROPRIETARY TO MOLEX INCORPORATED AND SHOULD NOT BE USED WITHOUT WRITTEN PERMISSION				

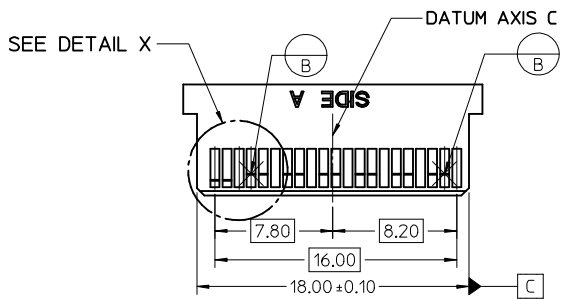
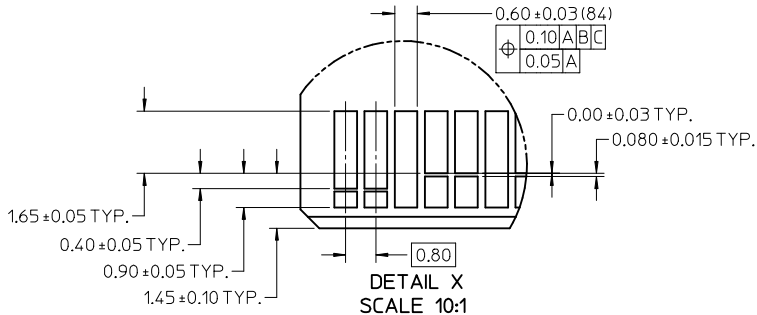
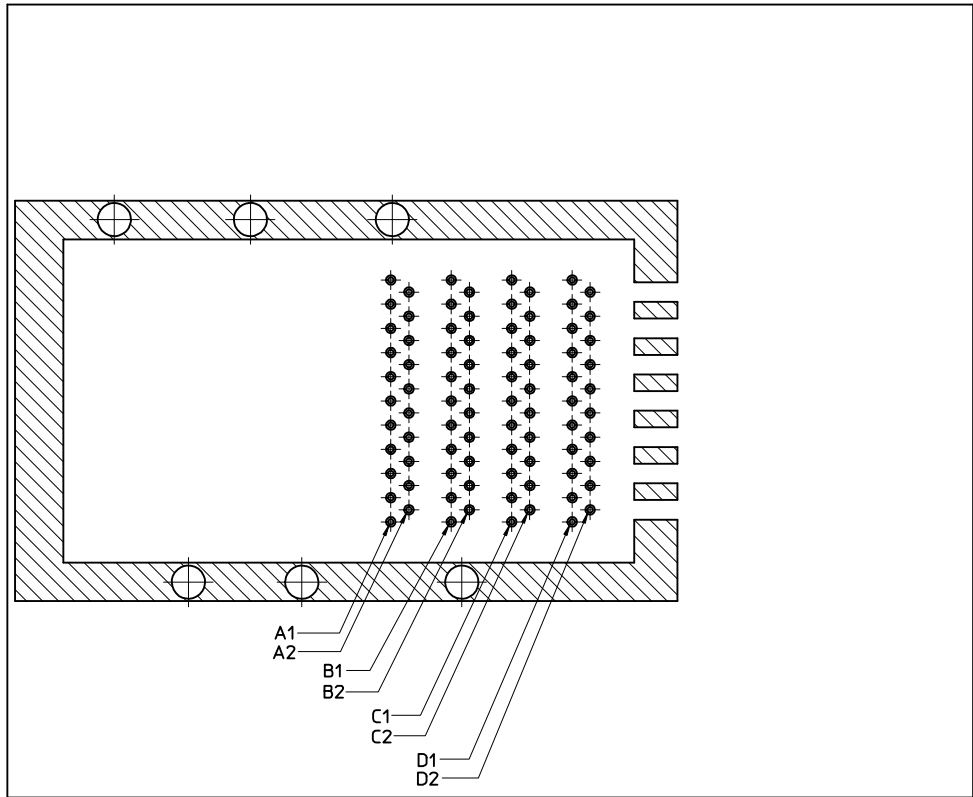
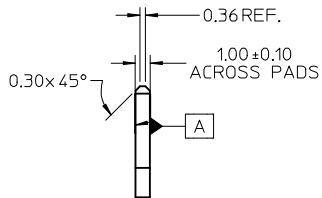
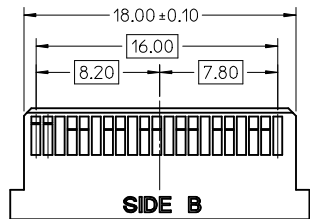

NOTES:

- 0.03 MINIMUM KEEP OUT FOR SOLDER MASK AROUND ALL PADS
- DATUM B TARGETS ARE DEFINED BY THE RESPECTIVE PAD CENTER LINES AND THE LEADING EDGE OF THE TARGET PADS

SEE SHEET 1 EC NO: UCP2013-0617 DRAWING PRATT 2012/08/28 CHKD: MBANAKIS 2012/08/29 APPR: MBANAKIS 2012/08/30	QUALITY SYMBOLS ▽=0 ▽=0	GENERAL TOLERANCES (UNLESS SPECIFIED) <table border="1"> <thead> <tr> <th></th> <th>mm</th> <th>INCH</th> </tr> </thead> <tbody> <tr> <td>4 PLACES</td> <td>± ---</td> <td>± ---</td> </tr> <tr> <td>3 PLACES</td> <td>± ---</td> <td>± ---</td> </tr> <tr> <td>2 PLACES</td> <td>± 0.25</td> <td>± ---</td> </tr> <tr> <td>1 PLACE</td> <td>± 0.25</td> <td>± ---</td> </tr> </tbody> </table>		mm	INCH	4 PLACES	± ---	± ---	3 PLACES	± ---	± ---	2 PLACES	± 0.25	± ---	1 PLACE	± 0.25	± ---	DIMENSION STYLE MM ONLY DRAWN BY DATE KLANG 2008/05/05 CHECKED BY DATE KLANG 2008/05/05 APPROVED BY DATE MBANAKIS 2008/05/19	SCALE 4:1 DESIGN UNITS METRIC THIRD ANGLE PROJECTION	TITLE IPASS PLUS HSC 84 HIGH SPEED CHANNEL 0.8MM I/O
		mm	INCH																	
	4 PLACES	± ---	± ---																	
	3 PLACES	± ---	± ---																	
2 PLACES	± 0.25	± ---																		
1 PLACE	± 0.25	± ---																		
DRAFT WHERE APPLICABLE MUST REMAIN WITHIN DIMENSIONS	MATERIAL NO. SEE CHART	MOLEX INCORPORATED DOCUMENT NO. SD-76105-584	SHEET NO. 3 OF 4																	
SIZE C	THIS DRAWING CONTAINS INFORMATION THAT IS PROPRIETARY TO MOLEX INCORPORATED AND SHOULD NOT BE USED WITHOUT WRITTEN PERMISSION																			

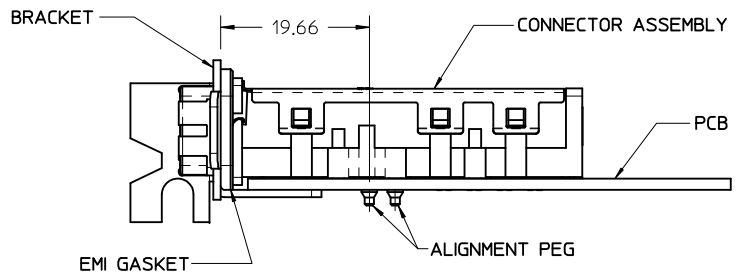
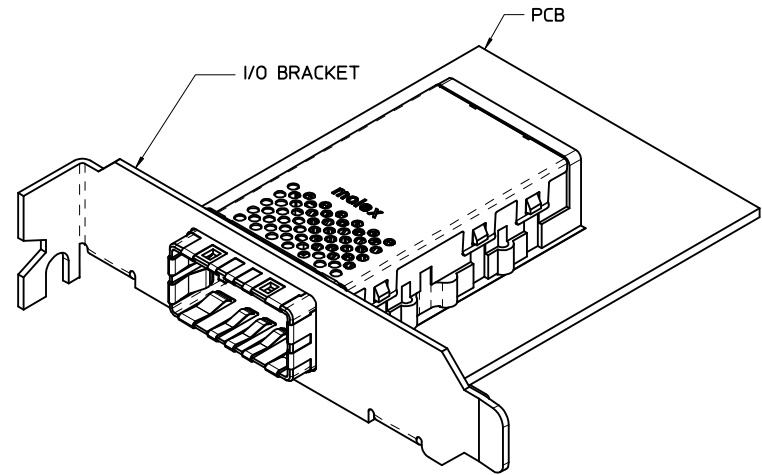

ASSEMBLED VIEW

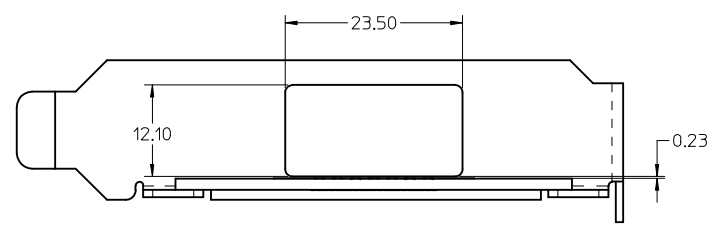

I/O BRACKET CUT-OUT
(NOT SUPPLIED)

SEE SHEET 1 EC NO: UCP2013-0617 DRAWING: GPRATT 2012/08/28 CHKD: MBANAKIS 2012/08/29 APPR: MBANAKIS 2012/08/30	DESCRIPTION REV	QUALITY SYMBOLS ▽=0 ▽=0	GENERAL TOLERANCES (UNLESS SPECIFIED)		DIMENSION STYLE MM ONLY	SCALE 2:1	DESIGN UNITS METRIC	THIRD ANGLE PROJECTION		
			mm	INCH	DRAWN BY KLANG	DATE 2008/05/05	TITLE IPASS PLUS HSC 84 HIGH SPEED CHANNEL 0.8MM I/O			
		4 PLACES ± --- ± --- 3 PLACES ± --- ± --- 2 PLACES ± 0.25 ± --- 1 PLACE ± 0.25 ± ---			CHECKED BY KLANG	DATE 2008/05/05				
				ANGULAR ±1/2°	DRAFT WHERE APPLICABLE MUST REMAIN WITHIN DIMENSIONS		APPROVED BY MBANAKIS	DATE 2008/05/19	MOLEX INCORPORATED	
			SEE SHEET 1		MATERIAL NO.	DOCUMENT NO. SD-76105-584	THIS DRAWING CONTAINS INFORMATION THAT IS PROPRIETARY TO MOLEX INCORPORATED AND SHOULD NOT BE USED WITHOUT WRITTEN PERMISSION			