

NOTES:

- MATERIALS: HOUSING - LIQUID CRYSTAL POLYMER (LCP)
GLASS-FILLED, UL94V-0
TERMINALS - HIGH PERFORMANCE COPPER ALLOY
- FINISH: 30μ MIN GOLD IN CONTACT AREA.
SELECTIVE TIN ON PCB TAILS,
NICKEL OVERALL.
- REFER TO MOLEX PRODUCT SPECIFICATION PS-76060-999 FOR PERFORMANCE SPECIFICATIONS AND ADDITIONAL PCB INFORMATION.
- THIS PART CONFORMS TO CLASS B REQUIREMENTS OF MOLEX COSMETIC SPEC PS-45499-002.
- PARTS PACKAGED PER PK-70873-7704.
- SEE SHEETS 2 & 3 FOR PART NUMBERS AND BOARD RELATIONSHIPS.
- MATES WITH IMPACT DC SERIES NO. 76460.
- REFER TO MOLEX PCB ROUTING GUIDE AS-76060-990 FOR ANTIPAD AND ROUTING RECOMMENDATIONS.
- *THESE DIMENSIONS REPRESENT THE AREA NEEDED TO ACCOMMODATE CONNECTOR INSERTION AND REPAIR ON THE PC BOARD. THIS IS REFERRED TO AS THE "CONNECTOR KEEP OUT ZONE" AND DOES NOT REPRESENT THE ACTUAL PERIMETER OF THE CONNECTOR. WHEN LAYING OUT A PC BOARD FOR CONNECTORS STACKED TOGETHER, USE A 1.9mm PROGRESSION.*

CONVERT TO LEAD-FREE EC NO: UCP2013-2078 DRWNT:IBARRA 2012/12/17 CHKD:JBINGHAM 2012/12/18 APPR:SMILLER 2012/12/31	QUALITY SYMBOLS ▽=0 ▽=0 ▽=0	GENERAL TOLERANCES (UNLESS SPECIFIED)		DIMENSION STYLE MM ONLY	SCALE 4:1	DESIGN UNITS METRIC	THIRD ANGLE PROJECTION	
		4 PLACES ± --- ± ---	DRAWN BY MSANDBERG	DATE 2008/03/11	IMPACT 2 PAIR HEADER UNGUIDED ASSEMBLY SALES DRAWING			
		3 PLACES ± --- ± ---	CHECKED BY TELO	DATE 2008/03/11				
		2 PLACES ± 0.13 ± ---	APPROVED BY JLAURX	DATE 2010/10/15	molex		DOCUMENT NO. SD-76455-001	SHEET NO. 1 OF 3
1 PLACE ± 0.25 ± ---		ANGULAR ±1/2°		SEE TABLE				
0 PLACE ± --- ± ---		DRAFT WHERE APPLICABLE MUST REMAIN WITHIN DIMENSIONS		THIS DRAWING CONTAINS INFORMATION THAT IS PROPRIETARY TO MOLEX. INCORPORATED AND SHOULD NOT BE USED WITHOUT WRITTEN PERMISSION				

PART NUMBER TABLE

MATERIAL NUMBER	# OF COLUMNS	# OF DIFF PAIR	DIM "A"	DIM "B"	DUAL END WALL OPTION
76455-*12*	10	20	21.7	17.10	
76455-*62*	16	32	33.1	28.50	

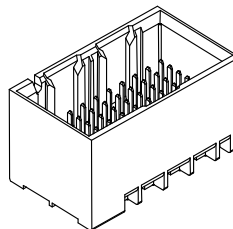

DUAL END
WALL OPTION

MATERIAL NUMBER	# OF COLUMNS	# OF DIFF PAIR	DIM "A"	DIM "B"	LEFT END WALL OPTION
76455-*11*	10	20	20.3	17.10	
76455-*61*	16	32	31.7	28.50	

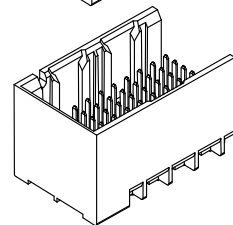

LEFT END
WALL OPTION

MATERIAL NUMBER	# OF COLUMNS	# OF DIFF PAIR	DIM "A"	DIM "B"	RIGHT END WALL OPTION
76455-*13*	10	20	20.3	17.10	
76455-*63*	16	32	31.7	28.50	

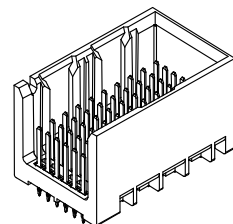

RIGHT END
WALL OPTION

MATERIAL NUMBER	# OF COLUMNS	# OF DIFF PAIR	DIM "A"	DIM "B"	OPEN WALL OPTION
76455-*10*	10	20	18.9	17.10	
76455-*60*	16	32	30.3	28.50	

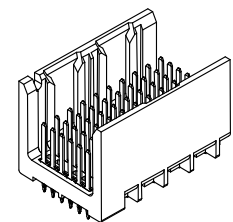

OPEN
WALL OPTION

PART NUMBER LOGIC

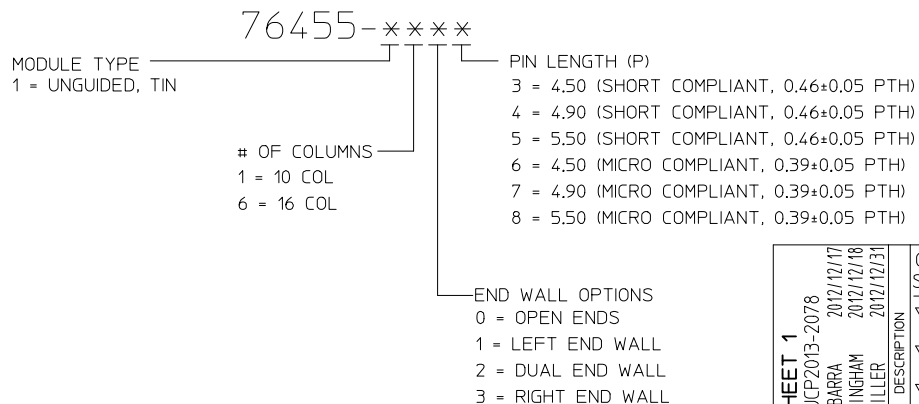

SEE SHEET 1 EC NO: UCP2013-2078 DRWN: TIBARRA 2012/12/17 CHKD: BINGHAM 2012/12/18 APPR: SMILLER 2012/12/31	QUALITY SYMBOLS	GENERAL TOLERANCES (UNLESS SPECIFIED)		DIMENSION STYLE MM ONLY	SCALE 2.5:1	DESIGN UNITS METRIC	THIRD ANGLE PROJECTION
		mm	INCH	DRAWN BY MSANDBERG	DATE 2008/03/11	TITLE IMPACT 2 PAIR HEADER UNGUIDED ASSEMBLY SALES DRAWING	
		4 PLACES ± ---	± ---	CHECKED BY TELO	DATE 2008/03/11	molex DOCUMENT NO. SD-76455-001	
		3 PLACES ± ---	± ---	APPROVED BY JLAURX	DATE 2010/10/15		
	2 PLACES ± 0.13	± ---	DRAFT WHERE APPLICABLE MUST REMAIN WITHIN DIMENSIONS		THIS DRAWING CONTAINS INFORMATION THAT IS PROPRIETARY TO MOLEX. INCORPORATED AND SHOULD NOT BE USED WITHOUT WRITTEN PERMISSION		
	1 PLACE ± 0.25	± ---					
	0 PLACE ± ---	± ---					

IMPACT 2 PAIR
BOARD RELATIONSHIPS

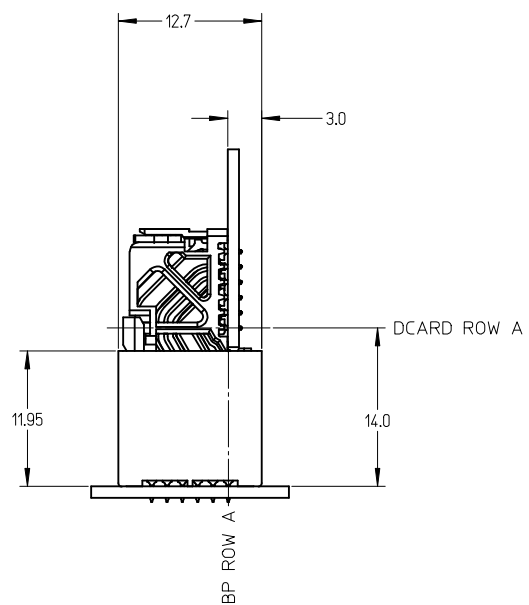
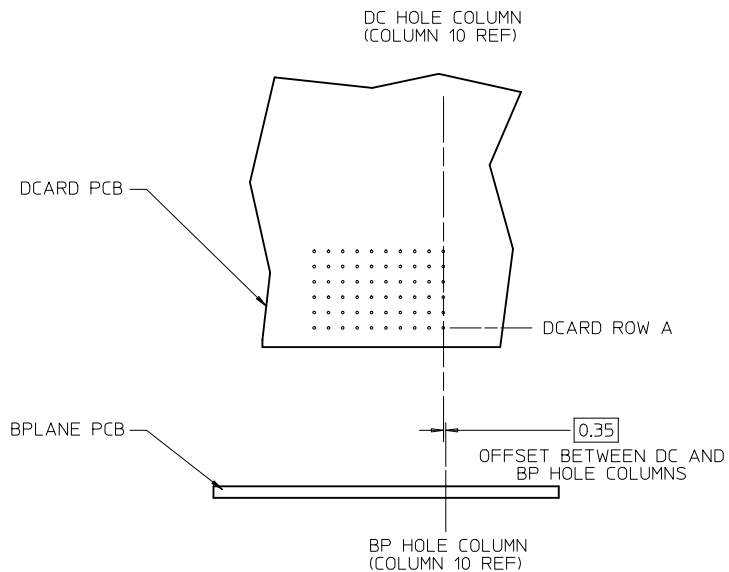
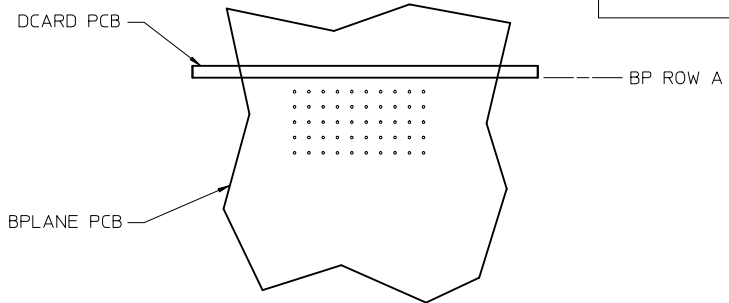

SEE SHEET 1 EC NO: UCP2013-2078 DRWN: TIBARRA 2012/12/17 CHKD: JB INGHAM 2012/12/18 APPR: SMILLER 2012/12/31	QUALITY SYMBOLS ▽=0 ▽=0 ▽=0	GENERAL TOLERANCES (UNLESS SPECIFIED) <table border="1"> <tr> <th></th> <th>mm</th> <th>INCH</th> </tr> <tr> <td>4 PLACES</td> <td>± ---</td> <td>± ---</td> </tr> <tr> <td>3 PLACES</td> <td>± ---</td> <td>± ---</td> </tr> <tr> <td>2 PLACES</td> <td>± 0.13</td> <td>± ---</td> </tr> <tr> <td>1 PLACE</td> <td>± 0.25</td> <td>± ---</td> </tr> <tr> <td>0 PLACE</td> <td>± ---</td> <td>± ---</td> </tr> </table>		mm	INCH	4 PLACES	± ---	± ---	3 PLACES	± ---	± ---	2 PLACES	± 0.13	± ---	1 PLACE	± 0.25	± ---	0 PLACE	± ---	± ---	DIMENSION STYLE MM ONLY DRAWN BY DATE MSANDBERG 2008/03/11 CHECKED BY DATE TELO 2008/03/11 APPROVED BY DATE JLAURX 2010/10/15	SCALE 2:1 DESIGN UNITS METRIC THIRD ANGLE PROJECTION	TITLE IMPACT 2 PAIR HEADER UNGUIDED ASSEMBLY SALES DRAWING molex
		mm	INCH																				
	4 PLACES	± ---	± ---																				
	3 PLACES	± ---	± ---																				
2 PLACES	± 0.13	± ---																					
1 PLACE	± 0.25	± ---																					
0 PLACE	± ---	± ---																					
MATERIAL NO. SEE TABLE	DOCUMENT NO. SD-76455-001	SHEET NO. 3 OF 3																					
DRAFT WHERE APPLICABLE MUST REMAIN WITHIN DIMENSIONS	SIZE C	THIS DRAWING CONTAINS INFORMATION THAT IS PROPRIETARY TO MOLEX INCORPORATED AND SHOULD NOT BE USED WITHOUT WRITTEN PERMISSION																					