

NOTES:

- PLATING FINISH :
 - 0 - 0.38um/15u" MIN. GOLD IN CONTACT AREA
1.90um/75u" MIN. TIN/LEAD
IN SOLDER TAIL AREA BOTH OVER
1.27um/50u" MIN. NICKEL OVERALL
 - 1 - 0.76um/30u" MIN. GOLD IN CONTACT AREA
1.90um/75u" MIN. TIN/LEAD
IN SOLDER TAIL AREA BOTH OVER
1.27um/50u" MIN. NICKEL OVERALL
- COPLANARITY IS TO BE MEASURED BY RESTING THE SOLDER TAIL ON A GAUGE SURFACE.
- PRODUCT SPECIFICATION PS-87049 APPLIES.
- RECOMMENDED PC BOARD THICKNESS IS 1.60 ± 0.10mm.

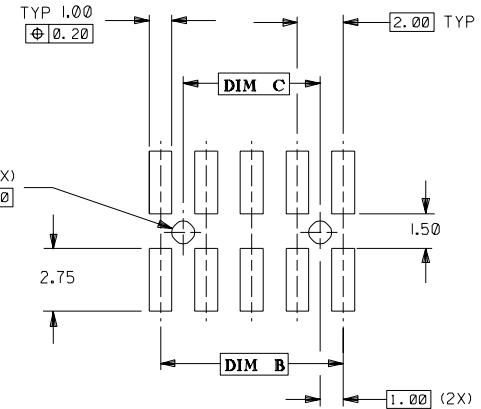
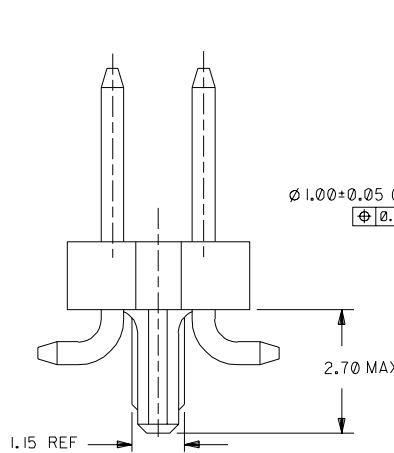
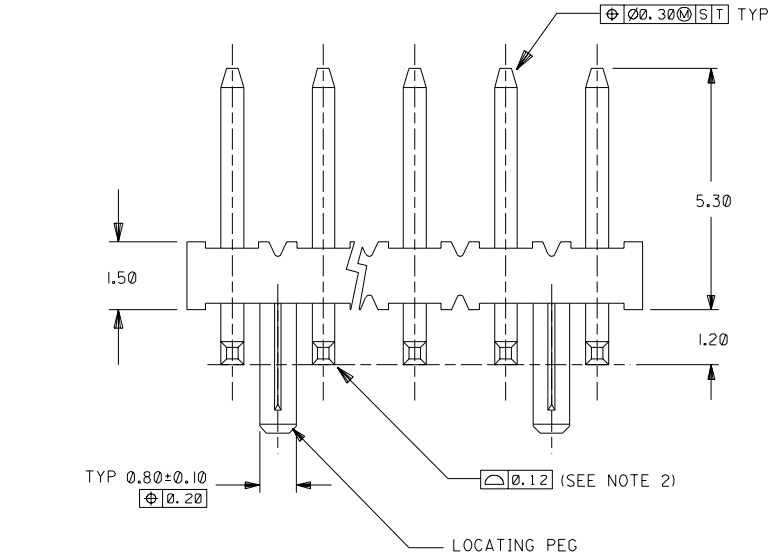

RECOMMENDED PCB PATTERN
(SCALE 5 : 1)

PART NO.	CKT SIZE	DIM A	DIM B	DIM C
		MM	MM	MM
87267 - 085*	8	7.90	6.00	4.00
87267 - 105*	10	9.90	8.00	6.00
87267 - 125*	12	11.90	10.00	8.00
87267 - 145*	14	13.90	12.00	10.00
87267 - 165*	16	15.90	14.00	12.00
87267 - 185*	18	17.90	16.00	14.00
87267 - 205*	20	19.90	18.00	16.00
87267 - 225*	22	21.90	20.00	18.00
87267 - 245*	24	23.90	22.00	20.00
87267 - 265*	26	25.90	24.00	22.00
87267 - 285*	28	27.90	26.00	24.00
87267 - 305*	30	29.90	28.00	26.00
87267 - 325*	32	31.90	30.00	28.00
87267 - 345*	34	33.90	32.00	30.00
87267 - 365*	36	35.90	34.00	32.00
87267 - 385*	38	37.90	36.00	34.00
87267 - 405*	40	39.90	38.00	36.00
87267 - 425*	42	41.90	40.00	38.00
87267 - 445*	44	43.90	42.00	40.00
87267 - 465*	46	45.90	44.00	42.00
87267 - 485*	48	47.90	46.00	44.00
87267 - 505*	50	49.90	48.00	46.00

PART NUMBER LEGEND

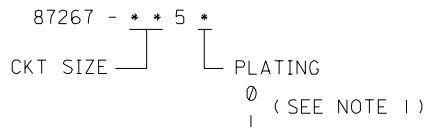

E4	CHG COPLANAR FROM 0.15 TO 0.12. (ECN* S1999-0469)	-	SEE	990604	MATERIAL : HOUSING : HIGH TEMP. NYLON, 94V-0 COLOR - BALCK PIN : 0.5MM SQ. PHOSPHOR BRONZE 510	MOLEX SINGAPORE PTE LTD SHEET 1 OF 1	GENERAL TOLERANCES ± 0.20/0.008 DWG. NO.: SD 87267-**-50	REV C4
C3	CHG 1.15±0.10 TO 1.15 REF (B4)	S70290	SEE	961212				
C2	REVISED PER ECN*	S40411	JACK TAY	930709	FINISH : SEE NOTE 1	DRAWN BY MAX LAI 920323	CHK'D BY G.W. ANG 920324	TITLE : "MILLI-GRID" 2mm DUAL ROW SMT HEADER (WITH PEG)
C1	REVISED PER ECN*	S30411	WENG TAY	930224				
C	REVISED PER ECN*	S30046	JACK TAY	920610	SCALE 10 : 1	APPR'D BY R. WONG 920324	SCALE 10 : 1	
B	RTM PER ECN*	S2523	MAX ANG	920506				
A	REL TO TOOLING PER ECN*	S2456	MAX ANG	920323				
LTR	REVISION RECORD	ECN	DR	CHK	DATE			

REVISE ONLY ON CAD SYSTEM