

EMC Series

- **UL1412 recognised***
- **Failsafe 240V mains fusing**
- **Good pulse handling capability**
- **Small size for power rating**
- **UL94-V0 flameproof protection**

* Values 22R and above. UL file number E234469

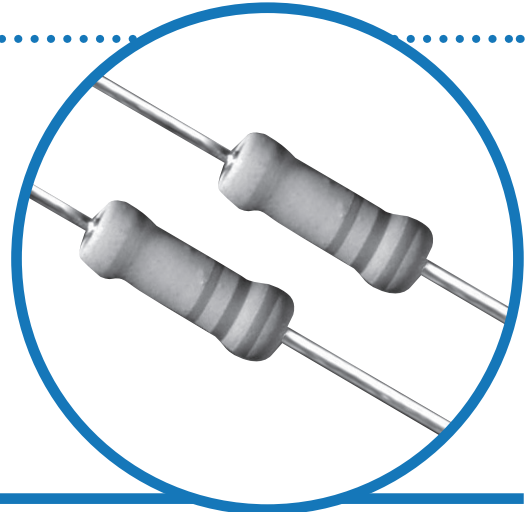

Electrical Data

| | | EMC2 |
|---------------------------|---------|-------------|
| Power rating at 70°C | Watts | 2 |
| Resistance range | Ohms | 4R7 – 68R |
| TCR (25 to 75°C) | ppm/°C | 100 |
| Isolation Voltage | Volts | 500 |
| Resistance Tolerance | % | 10, 20 |
| Standard Values | | E12 |
| Thermal Impedance | °C/Watt | 82 |
| Ambient temperature range | °C | -55 to +155 |

Physical Data

| Dimensions (mm) & Weight (g) | | | | | | | | |
|------------------------------|-------|-------|-------|-------|-------------------|-----------------|---------|--|
| Type | L max | D max | f min | d nom | PCB mount centres | Min bend radius | Wt. nom | |
| EMC2 | 10 | 4 | 27 | 0.8 | 18.4 | 1.2 | 0.55 | |

Construction

The metal film is deposited onto a high purity ceramic rod. End caps are force fitted and termination wires are welded to the end caps. Finally, a cement protection is applied to the resistor body prior to marking with indelible ink. The cement protection is applied in a manner that leaves the terminations completely clear. This permits a well-defined body length (clean lead to clean lead dimension L).

Terminations

Material: Solder-coated copper wire

Strength: The terminations meet the requirements of IEC 68.2.21

Solderability: The terminations meet the requirements of IEC 115-1 Clause 4.17.3.2

Solvent Resistance

The body protection and marking are resistant to all normal industrial cleaning solvents suitable for printed circuits.

General Note

TT electronics reserves the right to make changes in product specification without notice or liability. All information is subject to TT electronics' own data and is considered accurate at time of going to print.

Flammability

The resistor coating is UL94-V0 rated and will not burn or emit incandescent particles under any condition of applied temperature or power overload.

Marking

EMC resistors are colour coded with five bands. Four of the bands indicate value and tolerance in accordance with IEC62. Parts with 20% tolerance have no fourth band. A fifth yellow band denotes constant voltage fusibility.

Performance Data

| | | |
|---|-----|---------------|
| | | Maximum |
| Load at Rated Power: 1000hrs @ 70°C | ΔR% | 5 |
| Shelf life: 12 months at room temperature | ΔR% | 2 |
| Derating from rated power at 70°C | | Zero at 155°C |
| Climatic | ΔR% | 3 |
| Climatic Category | | 50/155/56 |
| Temperature rapid change | ΔR% | 0.5 |
| Resistance to solder heat | ΔR% | 0.5 |

Pulse Performance

IEC61000-4-5 1.2/50μs Pulse

Single Rectangular Pulse

Fusing Performance

EMC resistors fuse open circuit at overload powers exceeding 60W within the time indicated on the Fusing Characteristic. Their fusing performance at lower overload powers is not specified.

EMC resistors fuse safely in the event of a 115Vrms / 240Vrms overload (line / mains short circuit condition) without burning or emitting incandescent particles.

After fusing, the resistance is at least 100 times greater than the original nominal value.

Fusing Characteristic (Constant Voltage)

General Note

TT electronics reserves the right to make changes in product specification without notice or liability. All information is subject to TT electronics' own data and is considered accurate at time of going to print.

Application Notes

1. If the resistors are to dissipate full rated power, it is recommended that the terminations should not be soldered closer than 4mm from the body.
2. Due to operating temperature limits imposed by some PCB materials, derating may be necessary. An estimate of the temperature rise to be expected can be calculated using the thermal impedance figures given under Electrical Data.
3. To protect against fire under all conditions of overload, a positive clearance of at least 13mm should be provided between the body of the resistor and any combustible materials.
4. EMC resistors can also be supplied loose packed with radial, goalpost or lancet pre-formed leads, tape packed with radial pre-formed leads, or in blister tape with Z-formed leads for SMD mounting. Consult factory for details.

Packaging

Our standard packaging for EMC is taped and boxed. The critical dimensions are shown in Figure 1. The component wires will not protrude beyond the outside edge of the tapes. Alternative packaging is available by request.

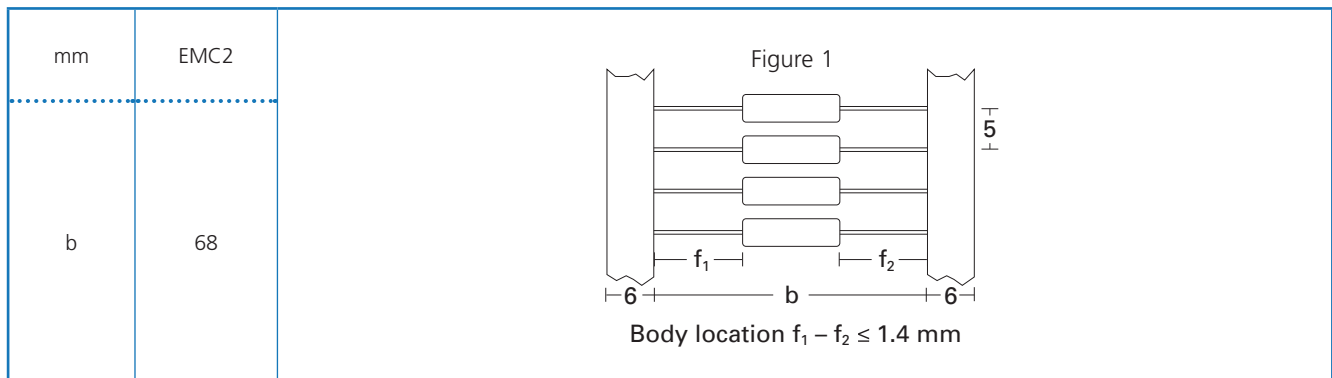

Standard Quantities Per Package

| | |
|-----------|------|
| Type | EMC2 |
| Ammo Pack | 2000 |

Ordering Procedure

Specify type reference, value and tolerance as shown in this example of EMC2 at 33Ω, 20%:

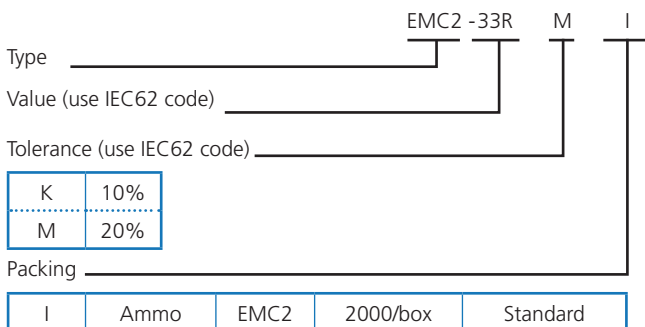

General Note

TT electronics reserves the right to make changes in product specification without notice or liability. All information is subject to TT electronics' own data and is considered accurate at time of going to print.