



# Evaluation Board For ADF4360-8 Integrated VCO & Frequency Synthesizer

EVAL-ADF4360-8EB1

## FEATURES

- Self-Contained Board for generating RF frequencies
- Flexibility for Reference Input, Output frequency, PFD Spacing & Loop Bandwidth
- Accompanying Software allows complete control of synthesizer functions from PC
- Battery Operated: 9V supplies
- Typical Phase Noise Performance of  $-141\text{dBc/Hz}$  @ 3MHz offset
- Typical Spurious Performance of  $-75\text{dBc/Hz}$  @ 1MHz offset.

## GENERAL DESCRIPTION

This ADF4360-8EB1 Evaluation board is designed to allow the user to evaluate the performance of the ADF4360-8 Frequency Synthesizers for PLL's (Phase Locked Loops). The block diagram of the board is shown below. It contains the ADF4360-8, a PC connector, plus SMA connectors for the power supplies, Reference Input, and RF outputs. It also contains a loop filter to complete the PLL. The eval board can be setup as necessary for the customer's PLL requirements. A cable is included with the board to connect to a PC printer port to allow software programmability.

The package also contains windows software to allow easy programming of the synthesizer.

## BLOCK DIAGRAM

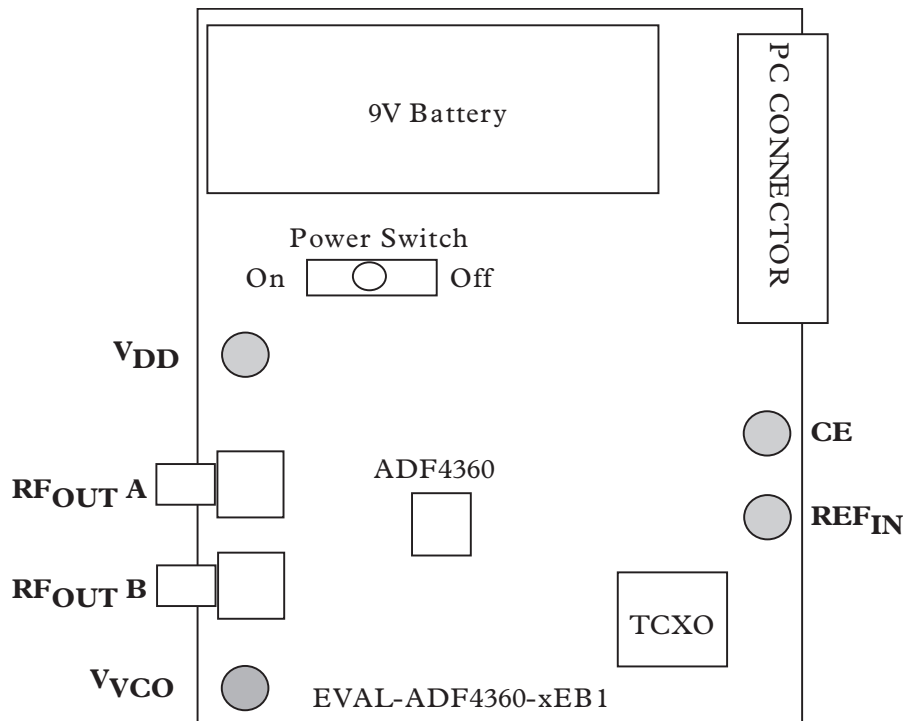

REV.PrA 04/04

© Analog Devices, Inc., 1999

Information furnished by Analog Devices is believed to be accurate and reliable. However, no responsibility is assumed by Analog Devices for its use, nor for any infringements of patents or other rights of third parties which may result from its use. No license is granted by implication or otherwise under any patent or patent rights of Analog Devices.

One Technology Way, P.O. Box 9106, Norwood, MA 02062-9106, U.S.A.  
Tel: 781-329-4700 Fax: 781-326-8703

## Hardware Description

The evaluation board comes with a cable for connecting to the printer port of a PC. The silk screen and cable diagram for the evaluation board are shown below. The board schematic is shown on pages 3 and 4.

If the version of version of ADIsimPLL that you are using is not configured for the ADF4360-8, then you can design the loop filter by selecting the ADF4001 as a synthesizer and inserting all other relevant parameters from the ADF4360-8 datasheet. Be careful to note that the charge pump current is half that of the ADF4001.

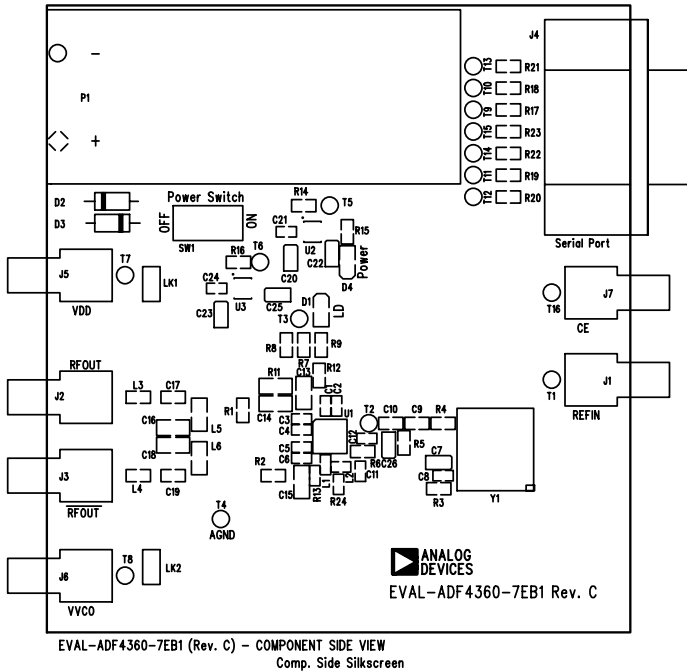
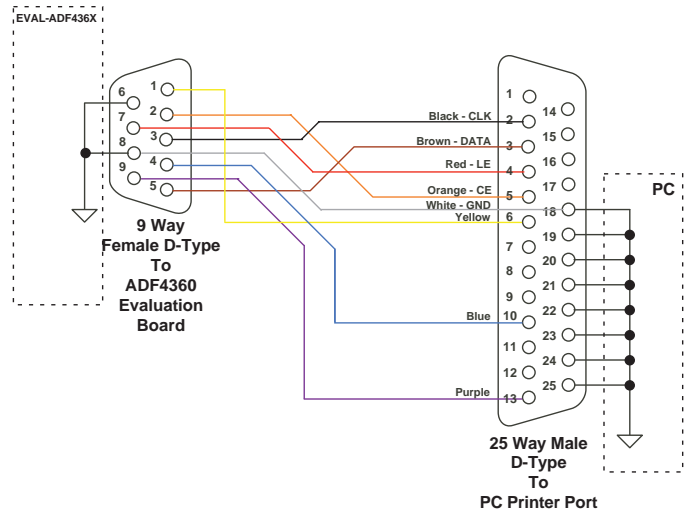

Figure 1. Evaluation Board Silkscreen

The board is powered from a single 9V battery. All components necessary for LO generation are catered for on-board, with some exceptions (listed on this page). A 10MHz TCXO from Fox provides the necessary Reference Input. Otherwise an External Reference signal can be connected via SMA1. The PLL comprises the ADF4360-7 and a passive loop filter. The VCO outputs are available at RF<sub>OUTA</sub> through a standard SMA connector, plus the complementary VCO output is available from RF<sub>OUTB</sub> complementary connector. If the user wishes they may use their own power supplies and reference input, they can use the SMA connectors as shown on the silkscreen and block diagram. Control of the Chip Enable pin can be achieved by inserting J7, and removing R12. The on board filter is a Third Order, Passive Low Pass Filter. This contains three capacitors, (C13, C14 & C15), plus two resistors (R10 & R11). To save Board space, The footprint for R10 is located on the underside of the board. For design of the loop filter, It is designed for a centre frequency of 120MHz, and a channel spacing of 1000kHz. It's bandwidth is 50kHz. To design a filter for different setups, Please use ADIsimPLL.



ADF4360-x CABLE CONNECTIONS

Figure 2. PC Cable Diagram

## EXTERNAL INDUCTOR OPTIONS

The ADF4360-8 uses External Inductors (L1 & L2) to setup the LC tank circuit of the VCO, The Eval board has a footprint for placement of these. A value of 220nH is inserted on the board giving a VCO centre frequency of 120MHz. To choose inductor values for other frequencies, please consult the part datasheet.

## RF OUTPUT STAGES

The output stage of the board is populated with a 330nH inductor to V<sub>vco</sub>, plus a dc-bypass capacitor (1nF). A footprint for a series L exists to provide better matching. If the user wishes, the board can be fitted with a shunt resistor to V<sub>vco</sub>, which results in less power but a more broadband circuit. Please consult the part datasheet for more information.

## ADI SimPLL

A copy of ADIsimPLL is also included on the eval kit CD. This software package designs, simulates and analyses the entire frequency domain and time domain response. You can use it to design an appropriate filter for the PLL. Various passive and active filter architectures are allowed.

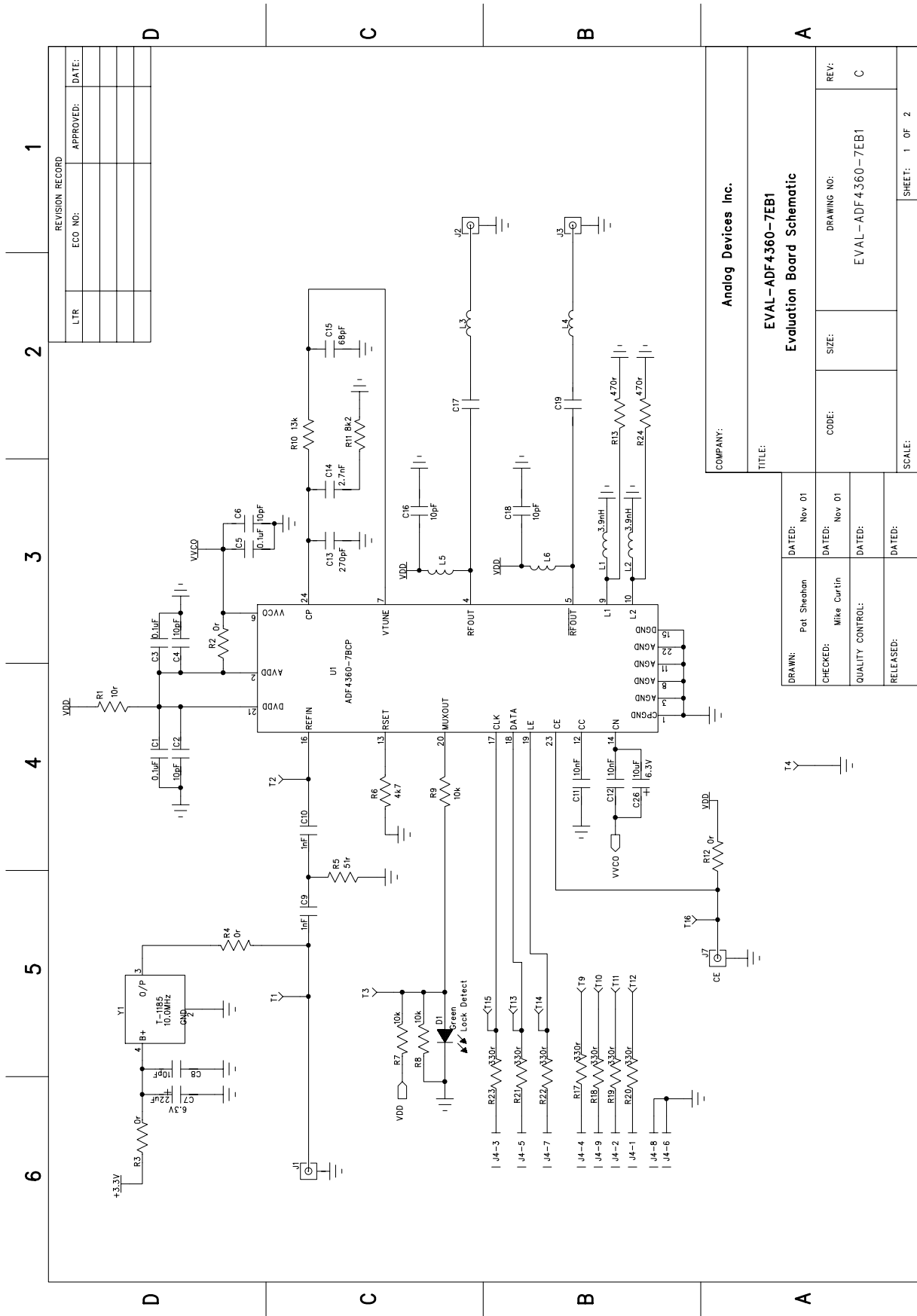

REVISION RECORD			
LTR	ECO NO:	APPROVED:	DATE:

COMPANY: Analog Devices Inc.			
TITLE: EVAL-ADF4360-7EB1 Evaluation Board Schematic			
DRAWN: Pat Sheehan	DATED: Nov 01	CODE:	REV: C
CHECKED: Mike Curtin	DATED: Nov 01	SIZE:	DRAWING NO: EVAL-ADF4360-7EB1
QUALITY CONTROL:	DATED:	SCALE:	SHEET: 1 OF 2
RELEASED:	DATED:		

Figure 3. Evaluation Board Circuit Diagram (Page 1)

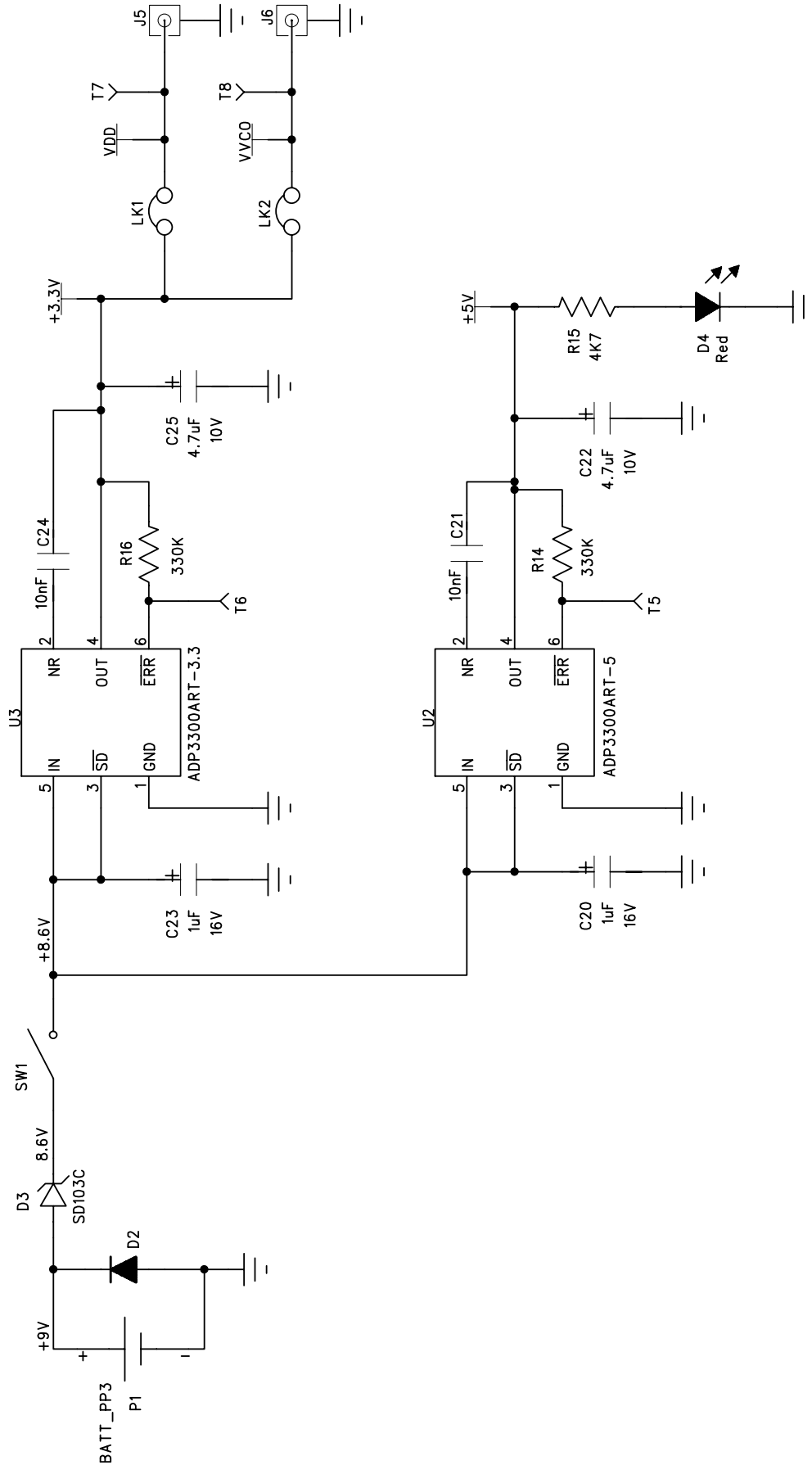

Figure 4. Evaluation Board Circuit Diagram (Page 2)

**Software Description**

The software comes on a CD. If the user double clicks on “setup.exe”, then the install wizard installs the software. Follow the on-screen directions. The software will be installed in a default directory called “C:/Program Files/ Analog Devices/ADF4360”. To run the software, simply double-click on “ADF4360.exe”.

Before the main software screen appears, the Device window appears, which will ask the user to choose which device is being evaluated. Choose the appropriate version of the ADF4360 and click OK. The Main Interface window will now appear. (See Figure 5).

**Programmable Software Settings**

Click on RF VCO Output Frequency, and the Output Frequency window will appear. Enter the desired output frequency (in MHz) and also the desired PFD frequency (in kHz) and click OK. Click on Reference Frequency and Insert the desired frequency in MHz, Again click OK.

Click on Charge Pump Current Setting 2 or Charge Pump Current Setting 1 and the Current Setting window will appear. Grab the pointer to set the Charge Pump Current Setting to the appropriate setting based on the loop design.

It may be necessary to adjust the core power current and the output power current to give optimum operation. These settings are clearly marked in the window shown below.

Click on the RF PD Polarity button to set the RF PD Polarity bit positive.

The part should now be now set up, and other features can now be examined by the user. To examine the contents written to each register, the Registers button can be selected below. As stated on the part's datasheet, The Correct sequence of Register writes is to the R Counter, The Function Latch and finally the N Counter Latch.

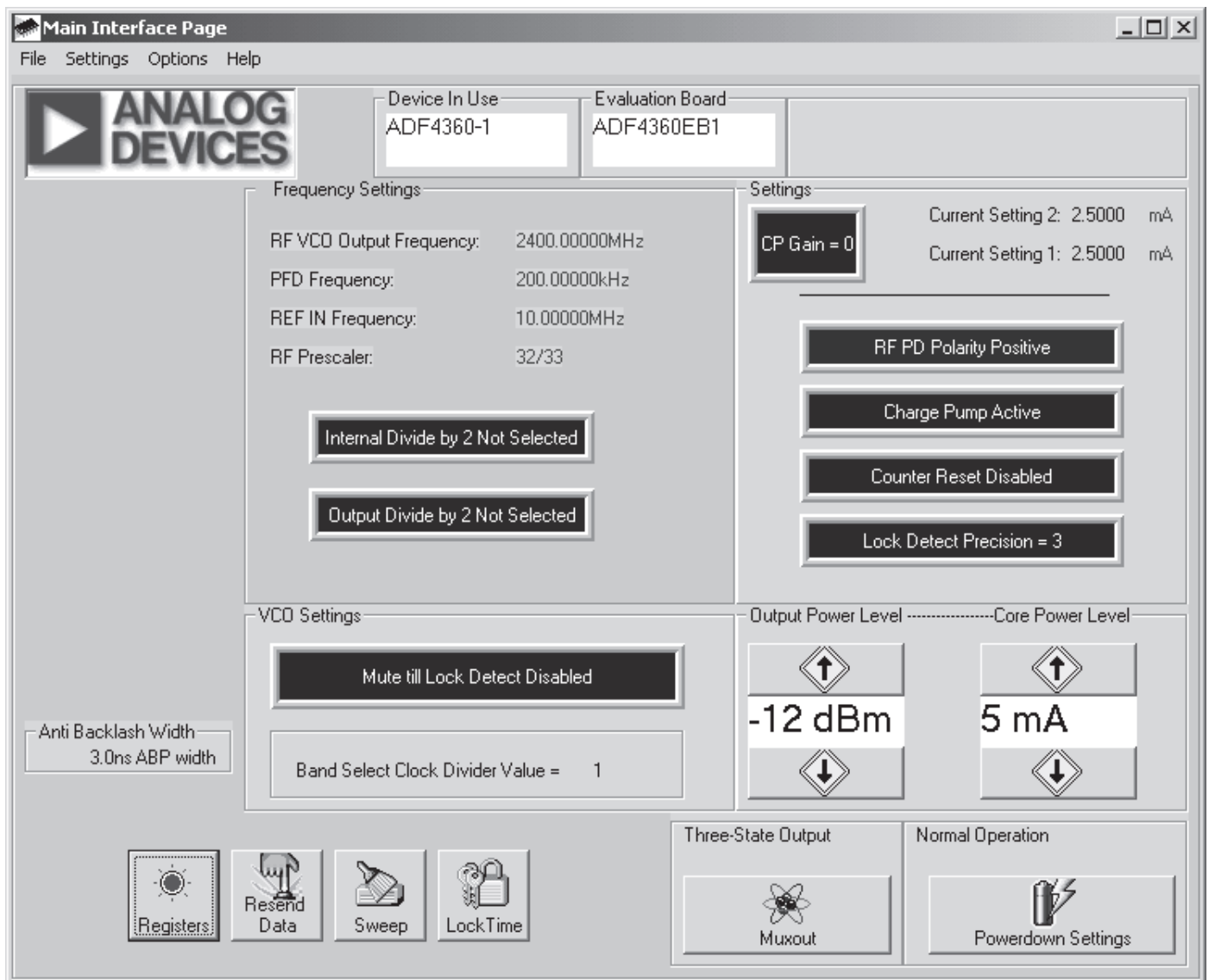

Figure 5. Software Front Panel

Table 1. Bill of Materials for the EVAL-ADF4360-8EB1

Item	Qty	Reference	Part Description	VALUE	PCB DECAL	STOCK NO
1	3	C1 C3 C5	CAP	0.1uF	0402 Case	FEC 301-9482
2	4	C2 C4 C6 C8	CAP	10pF	0402 Case	FEC 301-9160
3	1	C7	CAP+	22uF	CAPTAJ_A	FEC 197-038
4	2	C9 C10	Multilayer Ceramic Capacitor	1nF	0603 Case	FEC 317-202
5	4	C11 C12 C21 C24	Multilayer Ceramic Capacitor	10nF	0402 Case	FEC 301-9421
6	1	C13	Multilayer Ceramic Capacitor	120pF	0805 Case	FEC 301-9603
7	1	C14	Multilayer Ceramic Capacitor	1.5nF	0805 Case	FEC 722-182
8	1	C15	Multilayer Ceramic Capacitor	47pF	0805 Case	FEC 722-042
9	2	C16 C18	Multilayer Ceramic Capacitor	10pF	0805 Case	FEC 499-158
10	2	C17 C19	Multilayer Ceramic Capacitor	100pF	0603 Case	FEC 722-080
11	2	C20 C23	6.3V Tantalum Capacitor	1uF	CAPTAJ_A	FEC 498-701
12	2	C22 C25	6.3V Tantalum Capacitor	4.7uF	CAPTAJ_A	FEC 498-598
13	1	C26	6.3V Tantalum Capacitor	10uF	CAPTAJ_A	FEC 197-014
14	1	D1	Green Low Power LED		LED	FEC 515-620
15	1	D2	IN4001		D035	FEC 365-117
16	1	D3	SD103C Schottky Diode		DO35	SD103C
17	1	D4	Red Low Power LED		LED	FEC 515-607
18	2	J2 J3	Gold 90° 50□ SMA Socket		SMA_90DEG	Pasternack PE4118
19	4	J1 J5 J6 J7	Gold 90° 50□ SMA Socket		SMA_90DEG	Not Inserted
20	1	J4	90° 9 pin D-Type Male Connector		DB9-HM	FEC 150-750
21	2	L1 L2	Inductor	220nH	0402 Case	Coilcraft 0603CS-R22XJBW
22	2	L3 L4	1% Resistor (Surface Mount)	0r	0603 Case	FEC 772-227
23	2	L5 L6	1% Resistor (Surface Mount)	330nH	0805	Coilcraft 0805CS-330XJBW
24	2	LK1 LK2	2 pin header		SIP-2P	FEC 512-035
25	2	LK1 LK2	Shorting Shunt			FEC 150-410
26	1	P1	Pair PCB snap-on battery connector		BATT_PP3	FEC 723-988
27	1	R1	1% Resistor (Surface Mount)	10r	0603 Case	FEC 910-995
28	1	R10	1% Resistor (Surface Mount)	5.1k	0805 Case	FEC 321-8144
29	1	R11	1% Resistor (Surface Mount)	12k	0805 Case	FEC 911-987
30	2	R14 R16	1% Resistor (Surface Mount)	330K	0603 Case	FEC 911-537
31	7	R17 R18 R19 R20 R21 R22 R23	1% Resistor (Surface Mount)	330r	0603 Case	FEC 911-173
32	4	R2 R3 R4 R12	1% Resistor (Surface Mount)	0r	0603 Case	FEC 772-227
33	1	R5	1% Resistor (Surface Mount)	51r	0603 Case	FEC 357-1245
34	2	R6 R15	1% Resistor (Surface Mount)	4k7	0603 Case	FEC 911-318
35	2	R7 R8	1% Resistor (Surface Mount)	10k	0603 Case	FEC 911-355
36	1	R9	1 % Resistor	100r	0603 Case	FEC 612-364
37	2	R13 R24	5% Resistor	470r	0402 Case	FEC 194-922
38	1	SW1	SPDT Switch - (Washable)		SW_SIP-3P	FEC 150-559
39	16	T1-T16	Testpoint		TESTPOINT	FEC 240-345
40	1	U1	ADF4360-8BCP		LFCSP-24	ADI Free Issue
41	1	U2	ADP3300ART-5		SOT23-6	ADI Free Issue
42	1	U3	ADP3300ART-3		SOT23-6	ADI Free Issue
43	1	Y1	10 MHz TCXO (Fox-801)	10.0 MHz	OSC_TCXO	ADI Free Issue
44	4		Rubber Stick-On Feet	3M		FEC 148-922
45	1	Bare Board	Eval-ADF4360-8EB1 (Rev. 0) PCB	ADI		
46	1	P1	9V PP3 Battery	Duracell		FEC 908-526
			BC Tel No. 44-1236-730595			