

FEATURES

Operates from dual ± 12 V and +5 V supplies
On-board reference and output amplifiers
Direct hookup to the printer port of a PC
PC software for control of the DAC

GENERAL DESCRIPTION

This data sheet describes the evaluation board for the AD5444/AD5446 DACs. The AD5444/AD5446 are, respectively, CMOS 12-/14-bit current output, digital-to-analog converters (DACs). They operate from a +2.5 V to +5.5 V power supply, making them suited to battery-powered and other applications.

These DACs use data readback, allowing the user to read the contents of the DAC register via the DB pins. On power-up, the internal register and latches are filled with zeros and the DAC output is at zero scale.

Because the DACs are manufactured on a CMOS submicron process, they offer excellent four-quadrant multiplication characteristics.

The applied external reference input voltage (V_{REF}) determines the full-scale output current. An integrated feedback resistor (R_{FB}) provides temperature tracking and full-scale voltage output when combined with an external I-to-V precision amplifier.

Complete information about the DAC can be found in the AD5444/AD5446 data sheet that is available from Analog Devices, Inc.; it should be consulted in conjunction with this data sheet when using the evaluation board.

PACKAGE CONTENTS

The board consists of the AD5444/AD5446 and a current-to-voltage amplifier (AD8065). Included on the evaluation board is a 10 V reference (ADR01). Also, an external reference can be applied via an SMB input connector, and the SDO readback function can be enabled. The LDAC function is not available with the AD5444/AD5446.

Included in the evaluation kit is a CD ROM with self-installing software to control the DAC. The software allows the user to exercise all functions of the AD5444/AD5446.

FUNCTIONAL BLOCK DIAGRAM

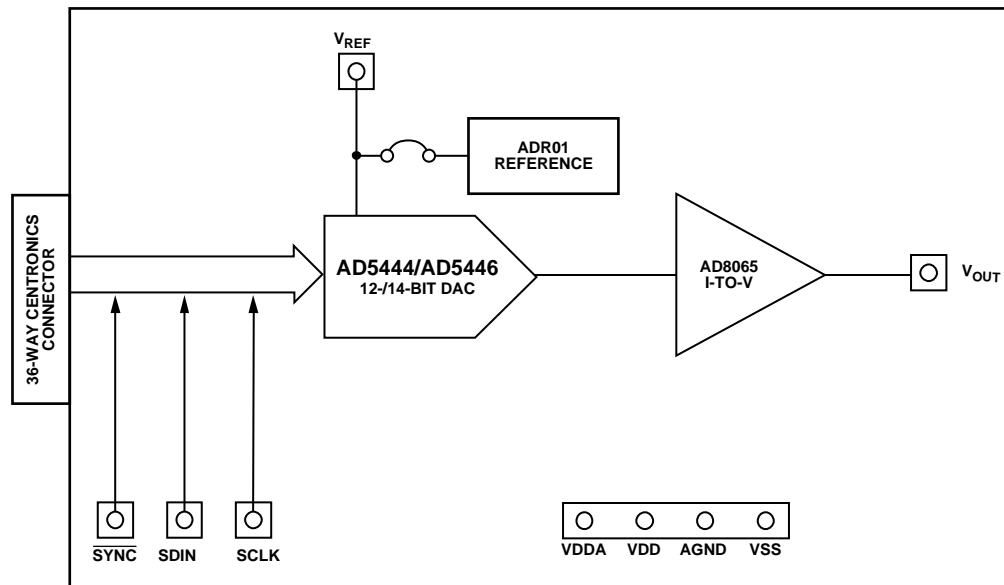

Figure 1.

Rev. 0

Evaluation boards are only intended for device evaluation and not for production purposes. Evaluation boards are supplied "as is" and without warranties of any kind, express, implied, or statutory including, but not limited to, any implied warranty of merchantability or fitness for a particular purpose. No license is granted by implication or otherwise under any patents or other intellectual property by application or use of evaluation boards. Information furnished by Analog Devices is believed to be accurate and reliable. However, no responsibility is assumed by Analog Devices for its use, nor for any infringements of patents or other rights of third parties that may result from its use. Analog Devices reserves the right to change devices or specifications at any time without notice. Trademarks and registered trademarks are the property of their respective owners. Evaluation boards are not authorized to be used in life support devices or systems.

TABLE OF CONTENTS

Features	1	Evaluation Board Software.....	3
General Description	1	Evaluation Board Schematics and Artwork	4
Package Contents.....	1	Ordering Information.....	7
Functional Block Diagram	1	Bill of Materials.....	7
Revision History	2	Ordering Guide	7
Evaluation Board Hardware and Software	3	ESD Caution.....	7
Evaluation Board Hardware.....	3		

REVISION HISTORY

2/08—Revision 0: Initial Version

EVALUATION BOARD HARDWARE AND SOFTWARE

EVALUATION BOARD HARDWARE

The board requires ± 12 V and +5 V supplies. The +12 V V_{DD} and the -12 V V_{SS} power the output amplifier, whereas the +5 V V_{DD1} powers the DAC. All supplies are decoupled to ground with 10 μ F tantalum and 0.1 μ F ceramic capacitors.

Link LK1 can be used to connect the on-board reference to the V_{REF} input, and Link LK2 can be used to enable the SDO readback function on-board.

EVALUATION BOARD SOFTWARE

Software Installation

The evaluation kit includes self-installing software on a CD ROM. The software is compatible with Windows® 95, Windows 97, Windows 2000, Windows NT, and Windows XP.

If the setup file does not run automatically when you insert the CD, run the **setup.exe** file directly from the CD.

Software Operation

1. Ensure that the Centronics cable connects the PC to the evaluation board.
2. From the **Analog Devices** menu, click **Start > All Programs > Analog Devices > AD5444_46 > AD5444_46 Evaluation Software**.

For older PCs, click **Start > Programs > Analog Devices > AD5444_46 > AD5444_46 Evaluation Software**.

The **AD5444/46 Evaluation Software** dialog box opens, as shown in Figure 2.

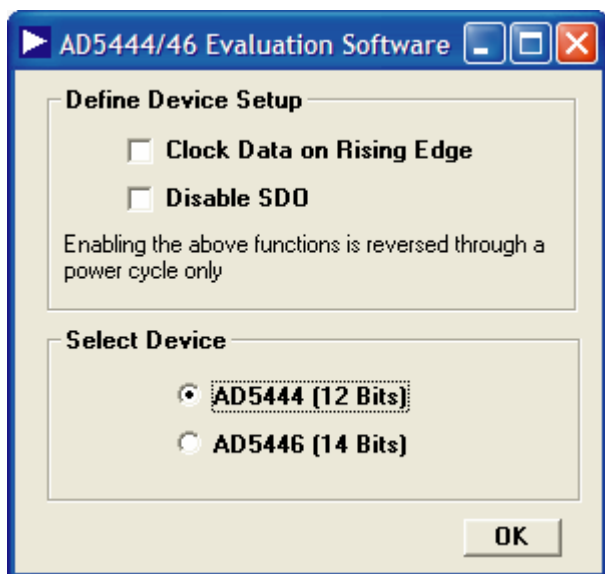

Figure 2. AD5444/46 Evaluation Software Dialog Box

3. To have the data clocked on the rising edge, select the **Clock Data on Rising Edge** check box. Deselect this option for the default setting (data is clocked on the falling edge).
4. To disable daisy chaining, select the **Disable SDO** check box. Deselect this option for the default setting (daisy chaining enabled).
5. To select the resolution of the part on the evaluation board, click the appropriate option button under **Select Device**.
6. Click **OK** to open the main window with drop-down menus (**File**, **Printer Port**, and **Help**), as shown in Figure 3.

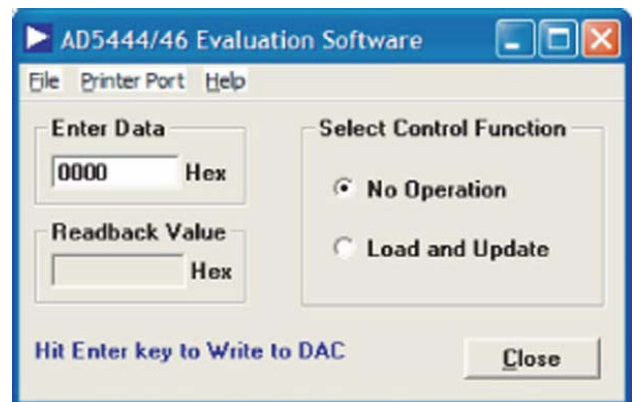

Figure 3. Main Window

The main window allows you to write a data-word to the DAC. You must enter the 12- or 14-bit word in hexadecimal. The main window also allows you to select the control functions of the AD5444/AD5446, as follows:

- **No Operation:** The DAC is not being used.
- **Load and Update:** Loads the DAC register with the entered data-word and displays the output in the **Readback Value** field, also in the main window.

The **Printer Port** menu allows you to select the printer port address to be used from a list of available addresses.

EVALUATION BOARD SCHEMATICS AND ARTWORK

900-61-550

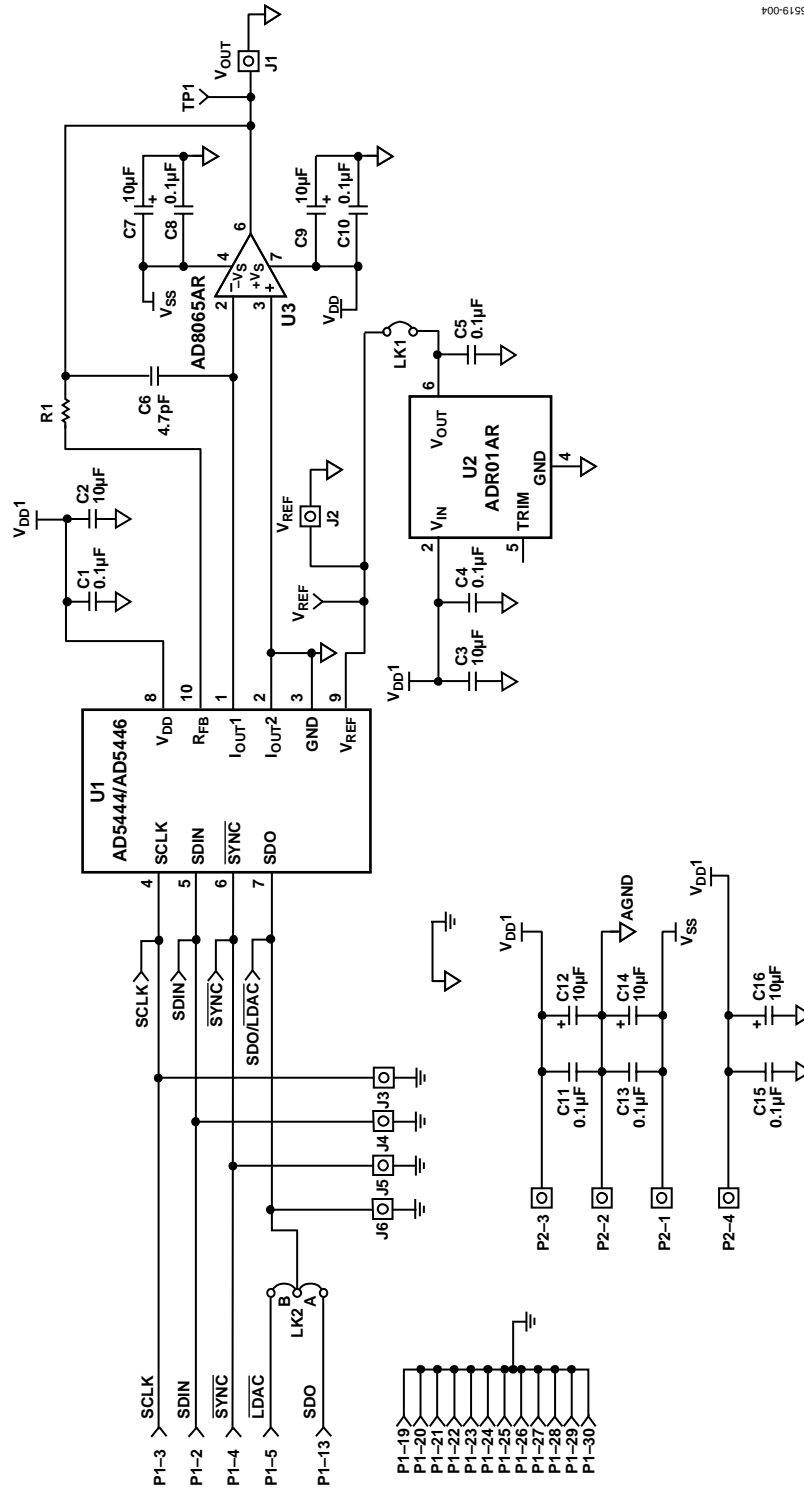

Figure 4. Evaluation Board Schematic

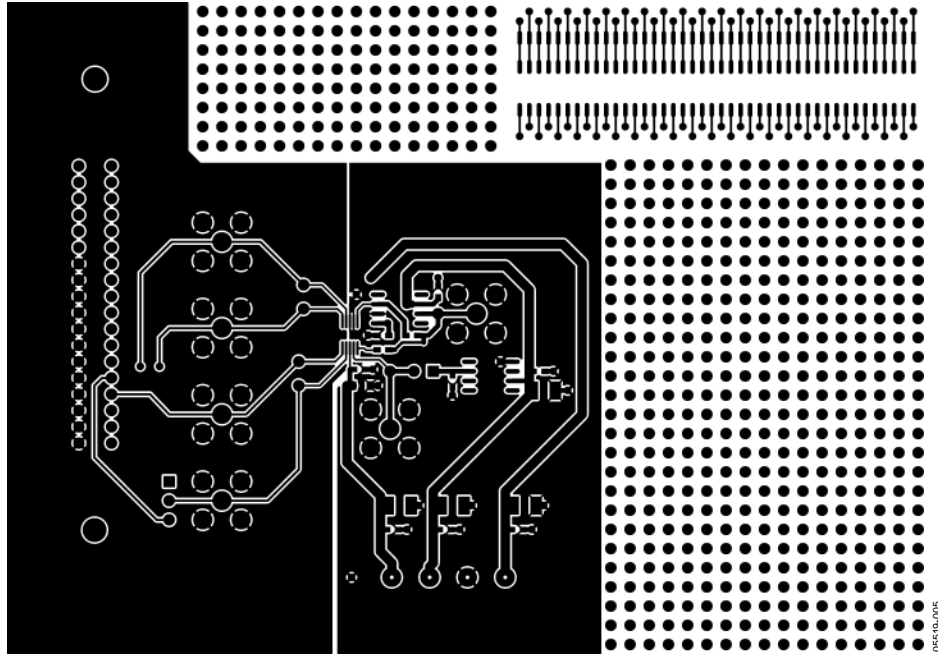

Figure 5. Component-Side Artwork

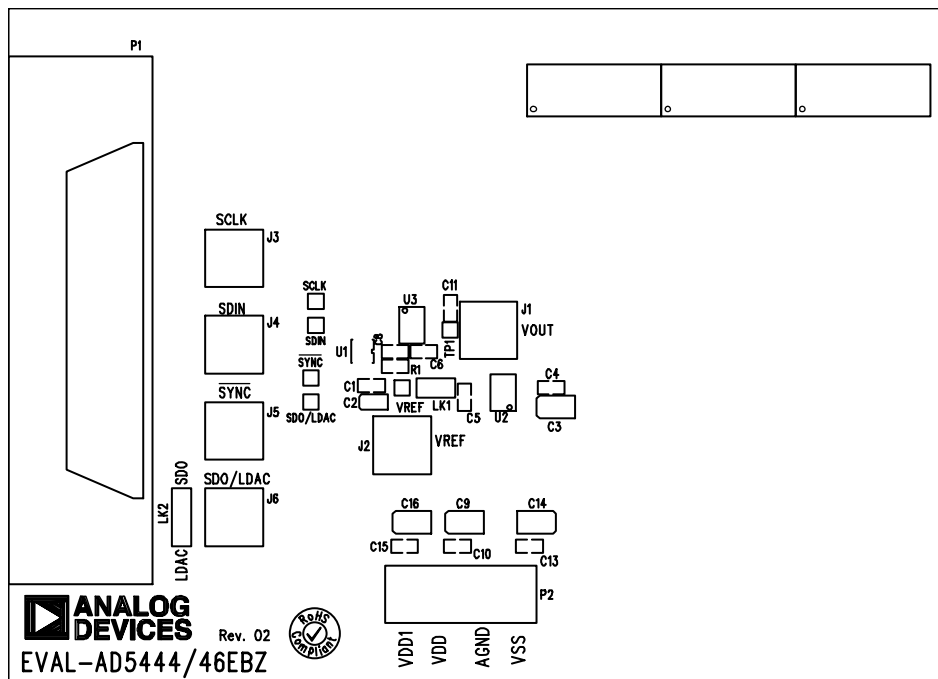

Figure 6. Silkscreen—Component-Side View (Top)

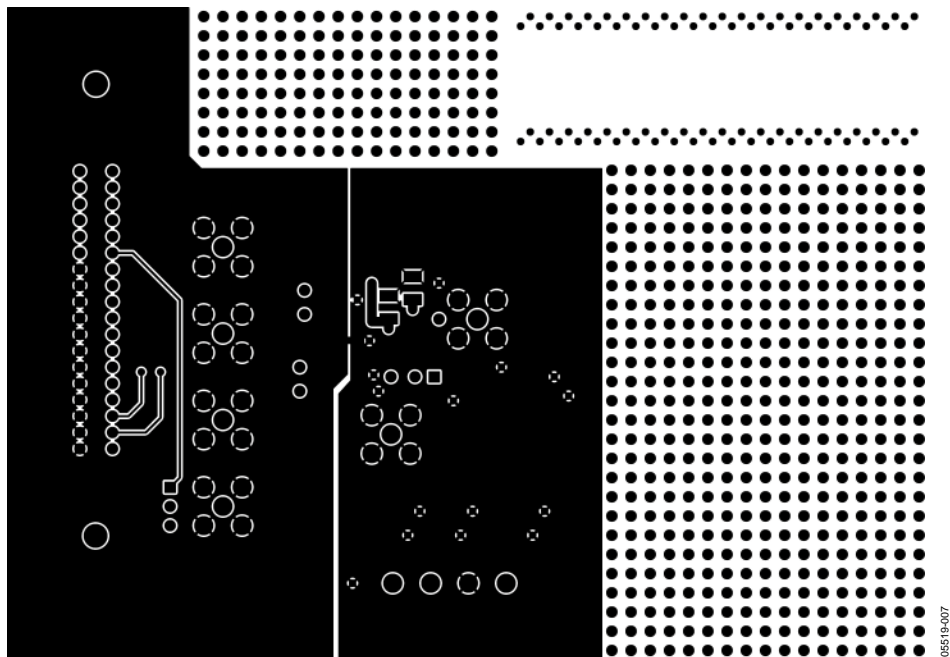

Figure 7. Solder-Side Artwork

05519-007

ORDERING INFORMATION

BILL OF MATERIALS

Table 1.

Qty.	Reference Designator	Part Description	PCB Decal	Supplier/Part Number ¹	SMD	Layer Name
8	C1, C4, C5, C8, C10, C11, C13, C15	0.1 μ F, 10%, X7R ceramic capacitor	0603	FEC 499-675	Yes	Top
1	C2	10 μ F, 10 V, 10% Tantalum capacitor, Taj series	CAP\TAJ_A	FEC 197-130	Yes	Top
6	C3, C7, C9, C12, C14, C16	10 μ F, 20 V, 10% Tantalum capacitor, Taj series	CAP\TAJ_B	FEC 197-427	Yes	Top
1	C6	4.7 pF, 10% NPO ceramic capacitor	0603	FEC 721-920	Yes	Top
6	J1 to J6	SMB socket	SMB	FEC 310-682	No	Top
1	LK1	2-pin header (2 \times 1)	SIP-2P	FEC 511-705 and FEC 140-411	No	Top
1	LK2	3-pin header (3 \times 1)	LINK-3P- NOTEXTSIP-2P	FEC 511-717 and FEC 140-411	No	Top
1	P1	36-pin Centronics connector	36WAY	FEC 147-753	No	Top
1	P2	4-pin terminal block	CON\POWER6	FEC151-791	No	Top
1	R1	0 Ω , 0.063 W resistor	0603	FEC 772-227	Yes	Top
6	SCLK, SDIN, SYNC, TP1, SDO, VREF	Red testpoint	TESTPOINT	FEC 240-345 (Pack)	No	Top
1	U1	AD5444/AD5446	MSO10	Analog Devices AD5444YRM/AD5446YRM	Yes	Top
1	U2	ADR01	SO8NB	Analog Devices ADR01AR	Yes	Top
11	U3	AD8065	SO8NB	Analog Devices AD8065AR	Yes	Top
	N/A	Rubber stick-on feet, each corner		FEC 148-922		

¹ FEC indicates the Farnell Electronic Components company.

ORDERING GUIDE

Model	Description
EVAL-AD5444EBZ ¹	AD5444 Evaluation Board
EVAL-AD5446EBZ ¹	AD5446 Evaluation Board

¹Z = RoHS Compliant Part.

ESD CAUTION



ESD (electrostatic discharge) sensitive device. Charged devices and circuit boards can discharge without detection. Although this product features patented or proprietary protection circuitry, damage may occur on devices subjected to high energy ESD. Therefore, proper ESD precautions should be taken to avoid performance degradation or loss of functionality.

EVAL-AD5444/AD5446

NOTES