

Customer Information Sheet

DRAWING No.: H3190-XX

SHEET 2 OF 2

IF IN DOUBT - ASK

©

NOT TO SCALE

THIRD ANGLE PROJECTION

ALL DIMENSIONS IN mm

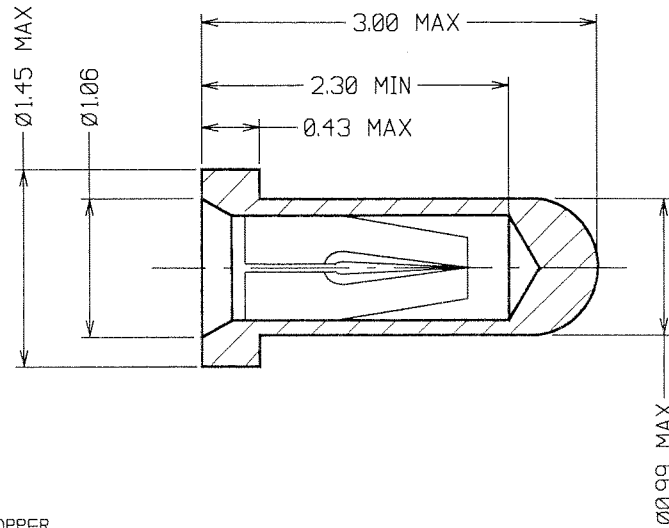

ORDER CODE:
H3190-XX
 FINISH: _____
 01 = GOLD CLIP, TIN SHELL
 05 = GOLD CLIP, GOLD SHELL
 46 = 100% TIN CLIP, 100% TIN SHELL

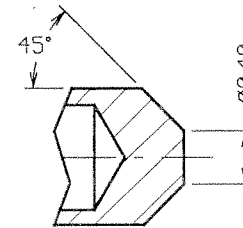

ALTERNATIVE END FORM (SEE NOTE 4)

SPECIFICATION:

MATERIAL:

CONTACT SHELL = BRASS
 CONTACT CLIP = BERYLLIUM COPPER

FINISH:

01 = 0.1µ GOLD CLIP, 4µ TIN SHELL
 05 = 0.1µ GOLD CLIP, 0.13µ GOLD SHELL
 46 = 1.3µ 100% TIN CLIP, 4µ 100% TIN SHELL

ELECTRICAL:

CURRENT RATING AT 25°C = 2A MAX
 CURRENT RATING AT 85°C = 1.75A MAX
 CONTACT RESISTANCE (INITIAL) = 15 MILLIOHMS MAX
 CONTACT RESISTANCE (AFTER CONDITIONING) = 25 MILLIOHMS MAX

MECHANICAL:

INSERTION FORCE (INITIAL) = 6N MAX, 2N MIN (Ø0.5mm GAUGE)
 WITHDRAWAL FORCE (INITIAL) = 1.5N MAX, 0.5N MIN (Ø0.5mm GAUGE)
 DURABILITY - 01, 05 = 500 OPERATIONS
 46 = 50 OPERATIONS

ENVIRONMENTAL:

OPERATING TEMPERATURE = -55°C TO +125°C

FOR COMPLETE SPECIFICATION, SEE COMPONENT SPECIFICATION C006XX (LATEST ISSUE)

NOTES:

1. RECOMMENDED PIN LENGTH = 2.40-2.30mm.
2. RECOMMENDED MOUNTING HOLE = Ø1.10-1.00mm.
3. RECOMMENDED PIN SIZE = Ø0.51-0.46mm.
4. FULL RADIUS OR CHAMFERED END FORM WILL BE SUPPLIED DEPENDING ON PRODUCTION BATCH.

MGP	6	13.06.07	9785
NAME	ISS.	DATE	C/NOTE
APPROVED: <i>[Signature]</i>			
CHECKED: <i>[Signature]</i>			
DRAWN: I SANDY			
CUSTOMER REF.:			
ASSEMBLY DRG.:			

HARWIN

HARWIN USA
 TEL: 603 893 5376
 FAX: 603 893 5396
 mis@harwin.com

HARWIN Europe (UK)
 TEL: 023 9231 4545
 FAX: 023 9231 4590
 mis@harwin.co.uk

HARWIN Asia
 TEL: +65 6 779 4909
 FAX: +65 6 779 3868
 mis@harwin.com.sg

THIS DRAWING AND ANY INFORMATION OR DESCRIPTIVE MATTER SET OUT HEREON ARE CONFIDENTIAL AND COPYRIGHT PROPERTY OF THE HARWIN GROUP AND MUST NOT BE DISCLOSED, LOANED, COPIED OR USED FOR MANUFACTURING, TENDERING OR FOR ANY OTHER PURPOSE WITHOUT THEIR WRITTEN PERMISSION.

TOLERANCES
 X. = ±1mm
 X.X = ±0.25mm
 X.XX = ±0.10mm
 X.XXX = ±0.01mm
 ANGLES = ±5°
 UNLESS STATED

MATERIAL:
 SEE ABOVE
FINISH:
 SEE ABOVE
S/AREA: mm²

TITLE:
 SUB-MINIATURE SOCKET ASSEMBLY
DRAWING NUMBER:
 H3190-XX
 SHT 2 OF 2