

LAN89218



High-Performance, Single-Chip 10/100 Ethernet Controller for Automotive Applications

Features

- Designed, fabricated, tested, characterized and qualified for automotive applications
- TrueAuto™ design, service and support
- Single-chip Ethernet controller
- Conforms with IEEE 802.3/802.3u standards
- Integrated Ethernet MAC and PHY
- 10BASE-T/100BASE-TX and HP Auto-MDIX support
- Supports reduced power modes
- Reduces dropped packets
- Flexible address filtering modes
- Integrated 1.8 V regulator
- High-performance 32-bit and 16-bit Host Bus Interface (HBI)
- Optional EEPROM interface
- Single 3.3 V power supply with 5.0 V tolerant I/O
- Low profile, 100-pin TQFP, lead-free RoHS-compliant package
- -40 °C to +85 °C automotive grade temperature support

Applications

- Diagnostic interface for dealership service bay
- Fast software download interface with an On Board Diagnostic (OBD) connector
- Gateway service interface for dealership, aftermarket, repair shop
- In-vehicle engineering development interface
- Vehicle manufacturing test interface for production plant assembly line
- Legislated inspections for emissions check and/or safety inspections

Description

The LAN89218 is a full-featured, single-chip 10/100 Ethernet controller which incorporates essential protocol requirements for operating an Ethernet/IEEE 802.3 10BASE-T and 802.3u 100BASE-TX node. It is specifically designed and tested for 16/32-bit automotive grade applications including diagnostic interface, system test interface, and fast software downloads where performance, flexibility, ease of integration and system cost control are required. ⇨



Ordering Information

The LAN89218 is available as:

LAN89218 Engineering Sample

Order No. B10247

LAN89218 Tape & Reel

Order No. B10246

In addition to an integrated Media Access Controller (MAC), SMSC's LAN89218 includes a physical interface (PHY) and an SRAM-like slave port, which is a simple, yet highly functional Host Bus Interface. This interface provides a glueless connection to most common 32-bit and 16-bit microprocessors and microcontrollers. Additionally, a programmable interrupt controller allows optimizing performance by selecting polarity, de-assertion interval, and an open-drain output configuration. A General Purpose (GP) timer can be used to generate periodic host interrupts.

The LAN89218 also includes deep transmit and receive data FIFOs interfacing the high-speed HBI to accommodate high-bandwidth and long-latency applications. The FIFOs act as a buffer between the HBI and MAC, passing all transmitted and received data and status information on separate paths.

Integrated checksum offload engines located in the MAC enable the automatic generation of the 16-bit checksum for received and transmitted Ethernet frames, offloading these tasks from the CPU. Memory buffer architecture allows the most efficient use of memory resources by optimizing packet granularity. The Ethernet MAC also supports features for reducing/eliminating packet loss. If the FIFO gets too full, the LAN89218 can automatically generate flow control packets to the remote node (when working in full-duplex mode) or assert back-pressure on the remote node (when working in half-duplex mode). Additionally, the MAC provides enhanced programmable features designed to minimize host supervision, bus utilization, and pre- or post-message processing. These

features include the ability to disable retries after a collision and checksum calculation for transmit and receive operations. With its internally separated transmit and receive data paths, the LAN89218 is optimized for high-performance applications, especially in full-duplex mode. The data paths manage both the payload and the status data.

The PHY, which interfaces to the MAC and LAN, can be configured for either 10 or 100 Mbps Ethernet operation in full- and half-duplex mode. It also supports HP Auto-MDIX for detection and correction of crossed Ethernet cabling.

SMSC automotive grade devices are specifically designed, fabricated, tested, characterized, qualified, and supported for use in automotive applications. TrueAuto robustness begins with proprietary design for reliability techniques within the silicon IC itself as well as in the design of the package.

Extensive technologies and processes, such as enhanced monitors, are used in fabrication of TrueAuto products in order to continuously drive improvements in accordance with SMSC's zero Defects per Million (DPM) goals.

Product qualification is focused on the most demanding customer expectations and exceeds many of the automotive reliability standards including AEC-Q100.

SMSC TrueAuto services are provided by a dedicated organization composed of sales, marketing, applications engineering, operations, quality, and product support personnel specialized in meeting the requirements of the automotive customer.

Internal Block Overview

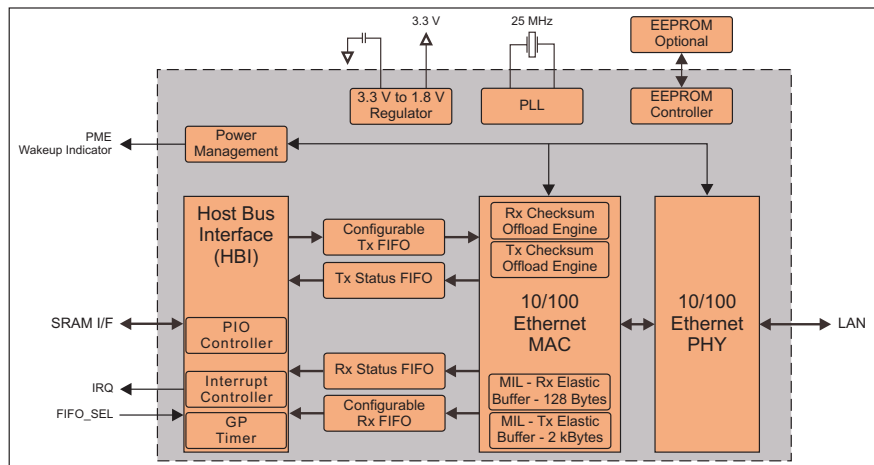

Copyright © 2008 - 2009 SMSC or its subsidiaries. All rights reserved. Although the information in this document has been checked and is believed to be accurate, no responsibility is assumed for inaccuracies. SMSC reserves the right to make changes to product descriptions and specifications at any time without notice. Contact your local SMSC sales office to obtain the latest product descriptions and specifications before placing your product order. The provision of this information does not convey any licenses under any patent rights or other intellectual property rights of SMSC or others. All sales are expressly conditional on your agreement to the terms and conditions of the most recently dated version of SMSC's standard Terms of Sale Agreement dated before the date of your order. Products may contain design defects or errors which may cause a product's functions to deviate from published product descriptions or specifications. Errata, listing these design defects or errors are available upon request. SMSC

products are not designed, intended, authorized or warranted for use in any life support or other application where product failure could cause or contribute to personal injury or severe property damage. Any and all such uses without prior written approval of an Officer of SMSC and further testing and/or modification will be fully at the risk of the customer. Copies of this document or other SMSC literature, as well as the Terms of Sale Agreement, may be obtained by visiting SMSC's website at <http://www.smsc.com>. SMSC, the SMSC logo, MOST and MediaLB are registered trademarks of Standard Microsystems Corporation ("SMSC"). Other names mentioned may be trademarks of their respective holders. All claims made herein speak as of the date of this material. The company does not undertake to update such statements. (12/08)

WEEE-Reg.-No. DE55114090