

DATE	REV.	DESCRIPTION	DR	CK	REL

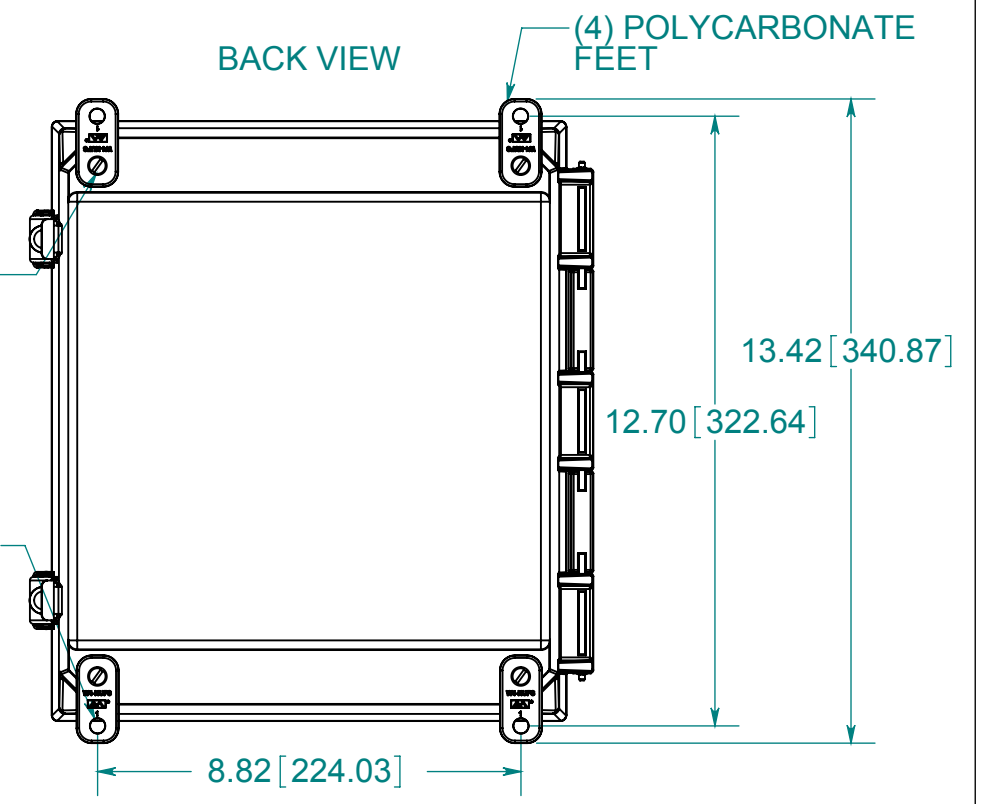
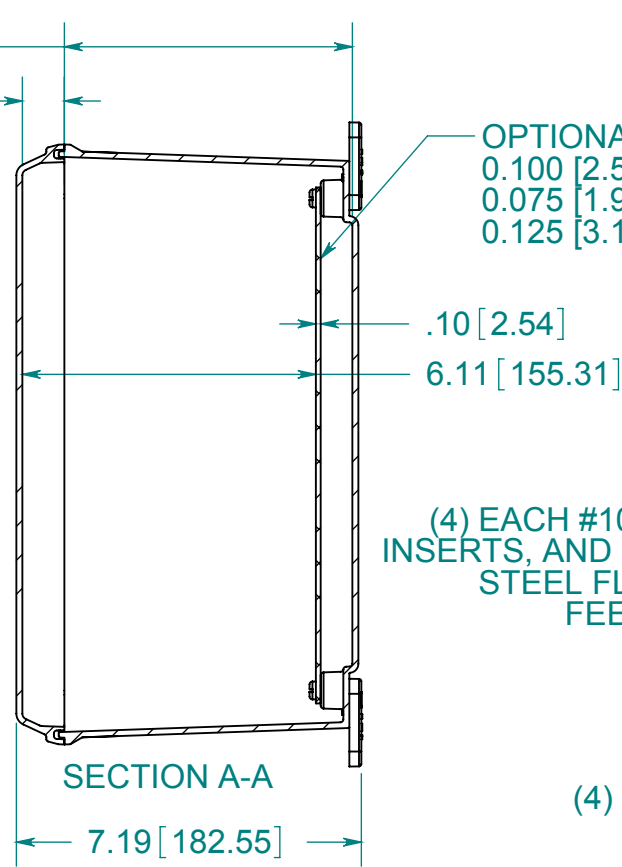
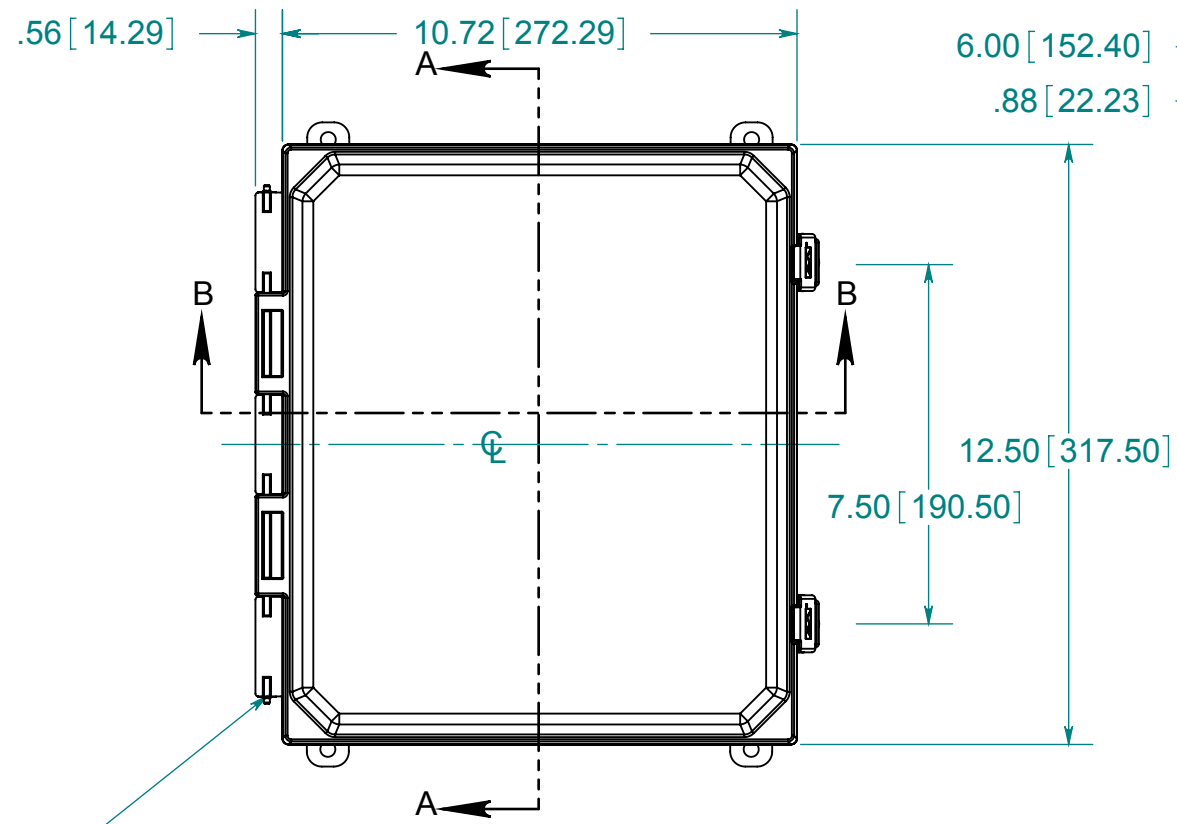

STAINLESS STEEL HINGE PIN AND (2) STAINLESS STEEL PUSH NUT FASTENERS

OPTIONAL BACK PANEL
 0.100 [2.54] TH'K- ALUMINUM
 0.075 [1.91] TH'K- WHITE STEEL & GALVANNEALED
 0.125 [3.18] TH'K- FIBERGLASS

(4) EACH #10-32 BRASS INSERTS, AND STAINLESS STEEL FLANGE AND FEET SCREWS

(4) ϕ .31 [7.95]

FRONT VIEW WITH COVER REMOVED AND BACK PANEL DISPLAYED

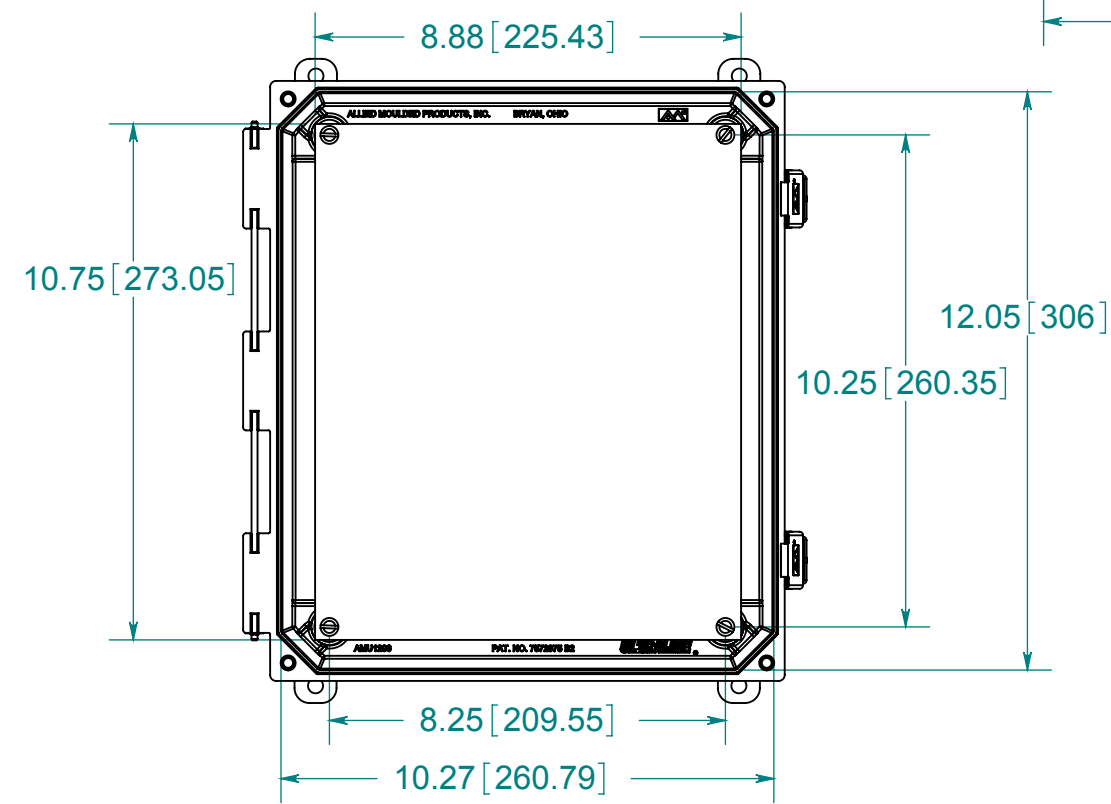

(2) STAINLESS STEEL LOCKABLE SNAP LATCHES

CLOSED CELL NEOPRENE GASKET

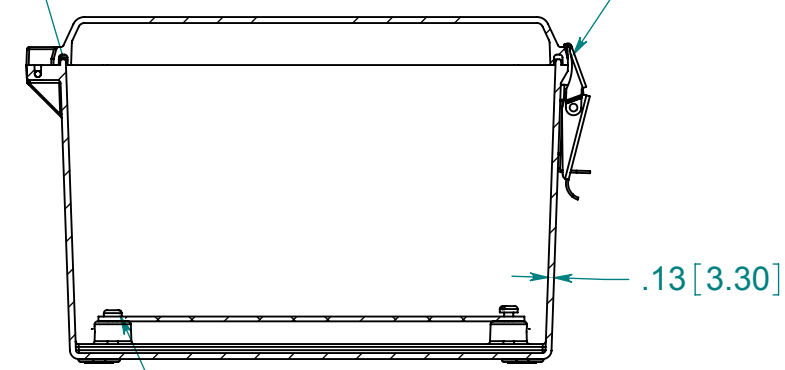

SECTION B-B

(4) EACH #10-32 BRASS INSERTS AND PLATED CARBON STEEL SCREWS

MATERIAL:
 BOX-COMPRESSION MOLDED FIBERGLASS REINFORCED POLYESTER
 COVER- COMPRESSION MOLDED FIBERGLASS REINGORCED POLYESTER
 CLEAR COVER AND WINDOWS- POLYCARBONATE

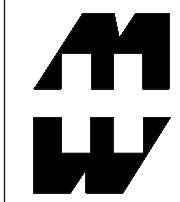

PART No. PJU1206L
 for more information visit
www.hammfg.com
 Data subject to change without notice
 Drawing Not to Scale