

▲ LED SPECIFICATIONS		
LED PARAMETER	UNITS	RED LED
FORWARD CURRENT	mA	20
FORWARD VOLTAGE	V	2.1 TYP, 2.6 MAX.
LUMINOUS INTENSITY	mcd	43 MIN- 100TYP

NOTE:

1. ALL DIMENSIONS IN MM [INCH]
2. GENERAL TOLERANCE: X.X=±0.4
X.XX=±0.25
3. TERMINAL NUMBERS FOR REF ONLY
4. CIRCUIT: SPST OFF-ON
5. CONTACT MATERIAL: Gold OVER SILVER
6. RATING: 100mA @ 24 VDC
7. ELECTRIC LIFE: 200,000 CYCLES AT FULL LOAD
8. CONTACT RESISTANCE: 100 milli-OHM max. (INITIAL)
9. INSULATION RESISTANCE: 1,000 MEGA-OHM min. @ 500VDC.
10. DIELECTRIC STRENGTH: 1,000 VAC rms.
- ▲ 11. OPERATING FORCE: 560 gf +/- 150 gf
12. OPERATING TEMPERATURE: -30°C TO +85°C.
13. CONTACT BOUNCE: 10ms MAX.
- ▲ 14. TRAVEL: 2.5±0.25mm
15. PANEL THICKNESS RANGE: 1.5 - 5.5 mm.
16. ▲ DENOTES CRITICAL PARAMETER.
17. 2002/95/EC (ROHS) COMPLIANT
18. MAX. MOUNTING TORQUE: 1.5Nm APPLIED TO THE HEX NUT
19. MOUNTING HARDWARE INCLUDED:
- T081101 LOCK WASHER (QTY 1)
- T081102 HEX NUT (QTY 1)
- T081103 O-RING (QTY 1) (B)
20. SEAL RATING: IP65 (B)

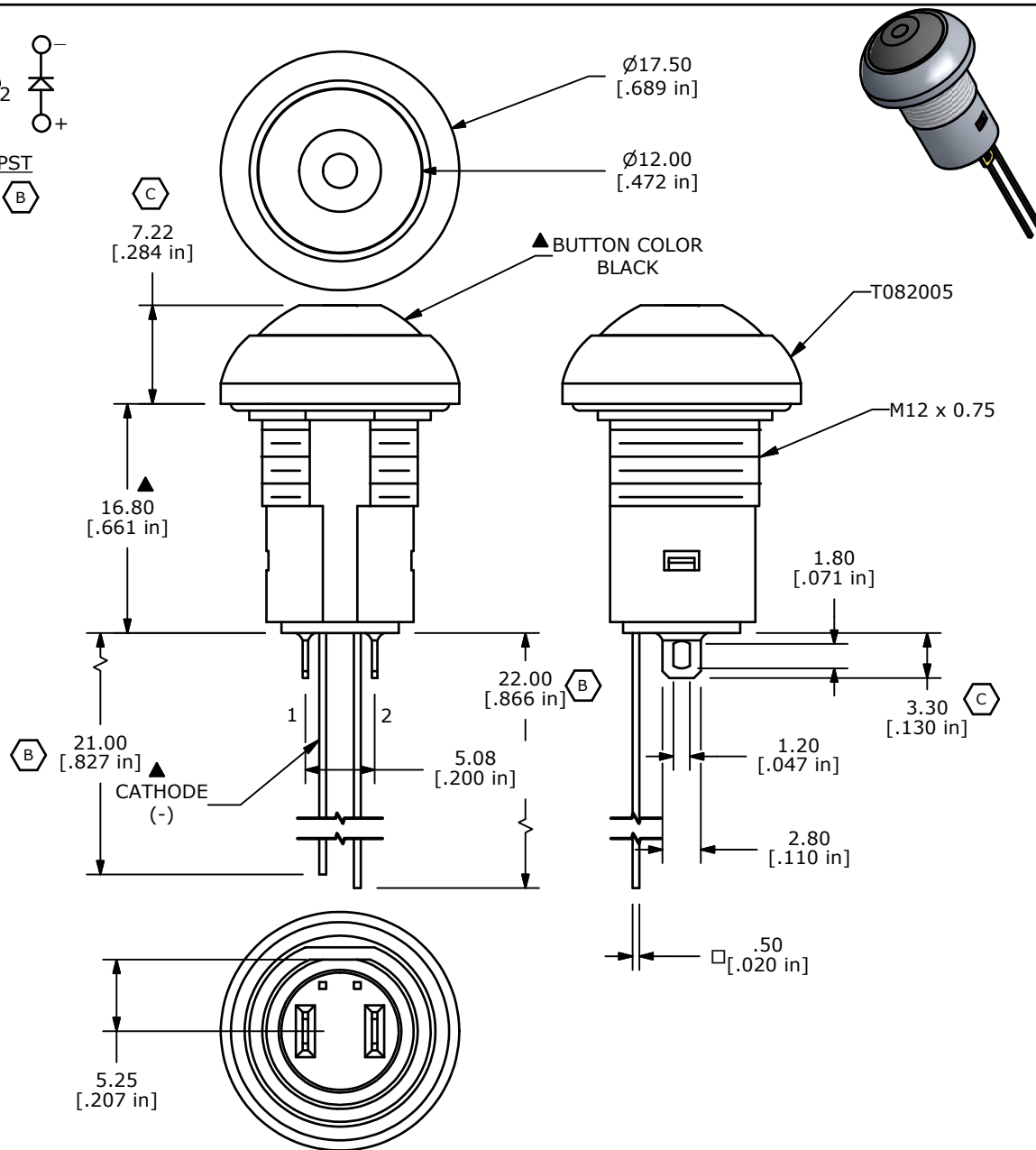

C	19895	DIMENSION CHANGES WAS 7.0 & 3.4	5/3/11	BGL
B	19358	MISC. DRAWING UPDATES	10/26/10	BMA
A	19126	NEW RELEASE	6/7/10	RC
REV	PCR NO	DESCRIPTION	DATE	BY



TITLE RP8200B2M1CEBLKBLKRED				
SCALE	DATE	DR	DWG	REV
2 : 1	6/7/2010	RC	ST082005	C

THE INFORMATION CONTAINED IN THIS DOCUMENT IS PROPRIETARY TO E-SWITCH AND IS NOT TO BE COPIED OR TRANSFERRED