

PANEL MOUNTING

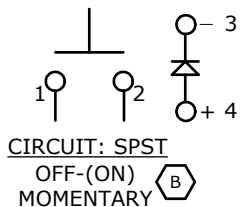

Ø13.60
[.535 in]

12.90
[.508 in]

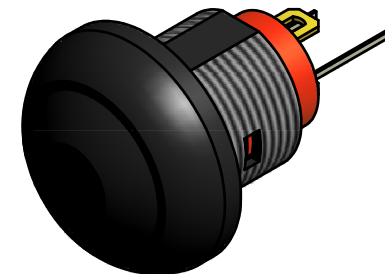
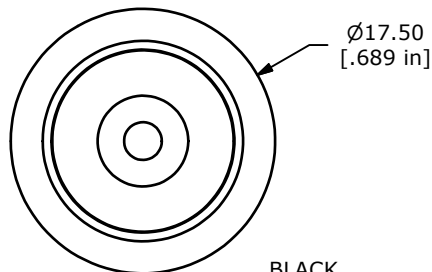

LED SPECS	UNITS	BLUE	
FORWARD CURRENT	mA	20 NOMINAL	
FORWARD VOLTAGE @20mA	V	3.2 TYP.	3.6 MAX.
LUMINOUS INTENSITY @ 20mA	mcd	150 TYP.	42 MIN.

NOTE:

1. ALL DIMENSIONS IN MM [INCH]
2. GENERAL TOLERANCE: X.X=±0.4
X.XX=±0.25
3. TERMINAL NUMBERS FOR REF ONLY
4. CIRCUIT: SPST OFF-MOMENTARY ON
5. CONTACT MATERIAL: Gold OVER SILVER
6. RATING: 500mA @ 48 VAC
200mA @ 50 VDC
200mA @ 250 VAC
7. ELECTRIC LIFE: 500,000 CYCLES AT FULL LOAD
8. CONTACT RESISTANCE: 50 MILLIOHM MAX. (INITIAL)
9. INSULATION RESISTANCE: 1,000 MEGA-OHM MIN. @ 500VDC.
10. DIELECTRIC STRENGTH: 1,500 VAC FOR 1 MINUTE.
11. OPERATING FORCE: 350 gf +/- 150 gf
12. OPERATING TEMPERATURE: -30°C TO +85°C.
13. CONTACT BOUNCE: 10ms MAX.
14. TRAVEL: 1.5±0.25MM
15. PANEL THICKNESS RANGE: 1.5 - 4.0 mm.
16. ▲ DENOTES CRITICAL PARAMETER.
17. 2002/95/EC (ROHS) COMPLIANT
18. MAX TORQUE APPLIED TO MOUNTING NUT: 1.5Nm
19. HARDWARE INCLUDED:
1) T081101 LOCK WASHER (QTY 1)
2) T081102 HEX NUT (QTY 1)
3) T081103 RUBBER O-RING (QTY 1)
20. SEAL RATING: IP65

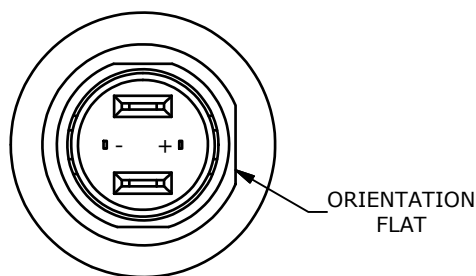
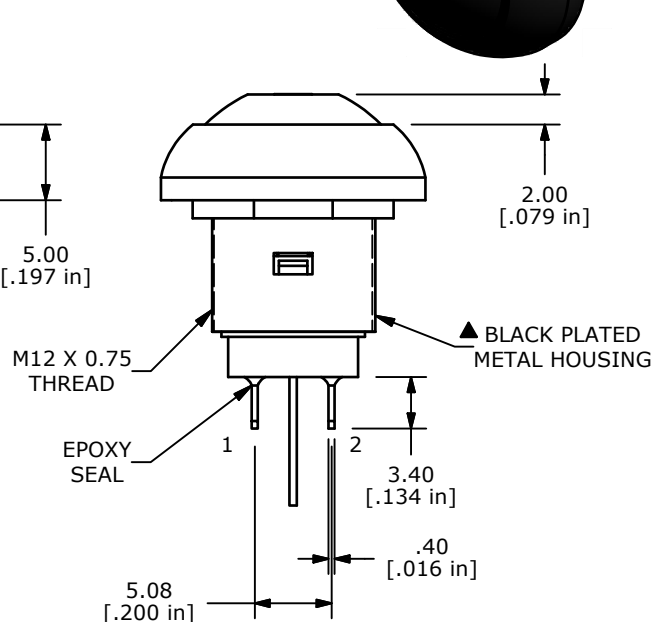
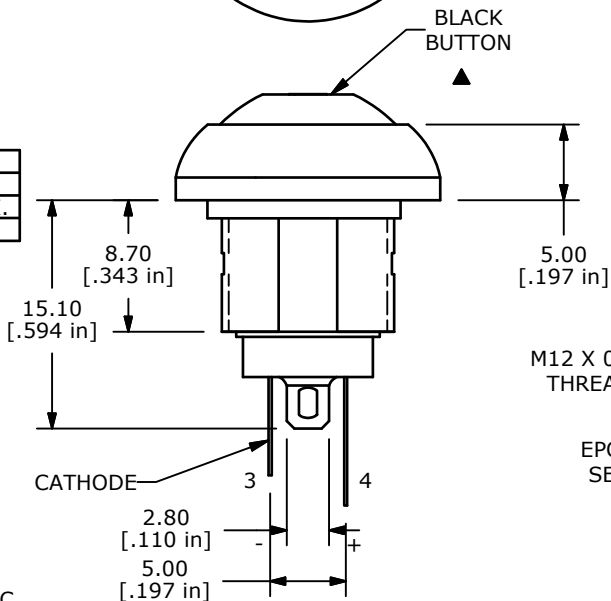

C	19683	UPDATE RATING	02/15/11	BMA
B	19358	MISC. DRAWING UPDATES	10/26/10	BMA
A	19294	NEW RELEASE	9/8/10	rc
REV	PCR NO	DESCRIPTION	DATE	BY

THE INFORMATION CONTAINED IN THIS DOCUMENT IS PROPRIETARY TO E-SWITCH AND IS NOT TO BE COPIED OR TRANSFERRED



TITLE RP8300B2M1CEBLKBLKBLU

SCALE	DATE	DR	DWG	REV
2:1	8/16/2010	rc	ST083003	C