

Description

The Si2128 is a universal analog TV tuner supporting all worldwide terrestrial and cable TV standards for analog TV reception. The Si2128 requires no external balun and offers the lowest-cost BOM for an analog TV tuner. By combining Silicon Labs' proven digital low-IF architecture with a 4th-generation RF front-end, the Si2128 maintains the highest performance that exceeds MOPLL-based tuners, including industry-leading 2nd-order distortion performance.

Compared with competing silicon TV tuners, the Si2128 delivers an unprecedented level of front-end integration, resulting in the lowest number of external BOM components. No external tracking filters, wire-wound inductors, LNAs, SAW filters or inductive power supply filtering components are needed. The Si2128 offers low power consumption as well as an option for single or dual power supply operation. Also included is an internal power-on reset circuit, eliminating the need for external brownout protection components or additional pins in module applications.

As with prior-generation Silicon Labs TV tuners, the Si2128 delivers superior picture quality and a higher number of received stations when compared to other silicon tuners and discrete MOPLL-based tuners. Incorporating worldwide field testing experience from three previous tuner generations in high-volume production, the Si2128 delivers the highest tolerance to real-world field reception conditions. The Si2128 also incorporates a harmonic-rejection mixer that delivers excellent immunity to Wi-Fi and LTE interference across the full RF input frequency range, with no need for external filtering components.

Features

- Worldwide analog TV tuner
 - NTSC, PAL/SECAM
 - 42–870 MHz frequency range
- Industry-leading margin to EN55020 and OpenCable™ specifications
- Lowest BOM for a silicon analog TV tuner
 - No balun at RF input
 - No external SAW filters or wire-wound inductors
 - Integrated LNAs and complete tracking filters
- Best-in-class real-world reception
 - Exceeds discrete MOPLL-based tuners
 - High immunity to Wi-Fi and LTE interference
- Low power consumption
 - 3.3 V and 1.8 V power supplies
 - Single-supply option for 3.3 V-only operation
- Integrated power-on reset circuit
- Low-IF output to SoC or external analog demodulator
- Standard CMOS process technology
- 4x4 mm, 28-pin QFN package
- RoHS compliant

Applications

- Analog tuner module
- TV with on-board analog front-end
- Analog portable TV and portable DVD player
- PC-TV accessories

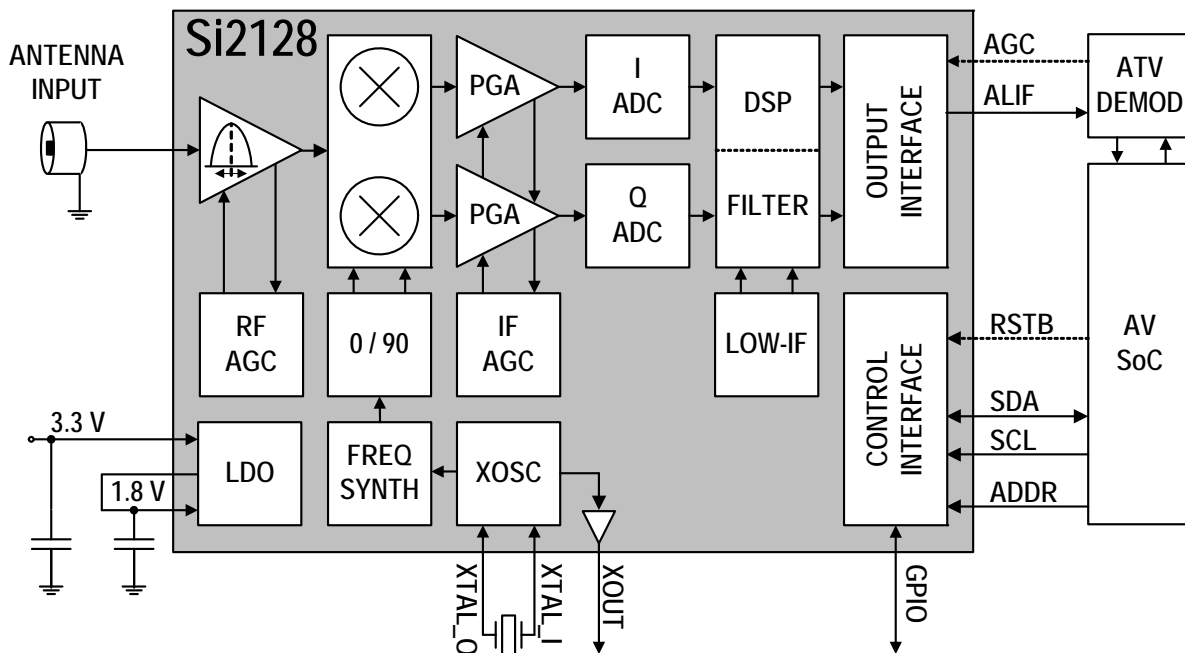

Application Example: Analog TV

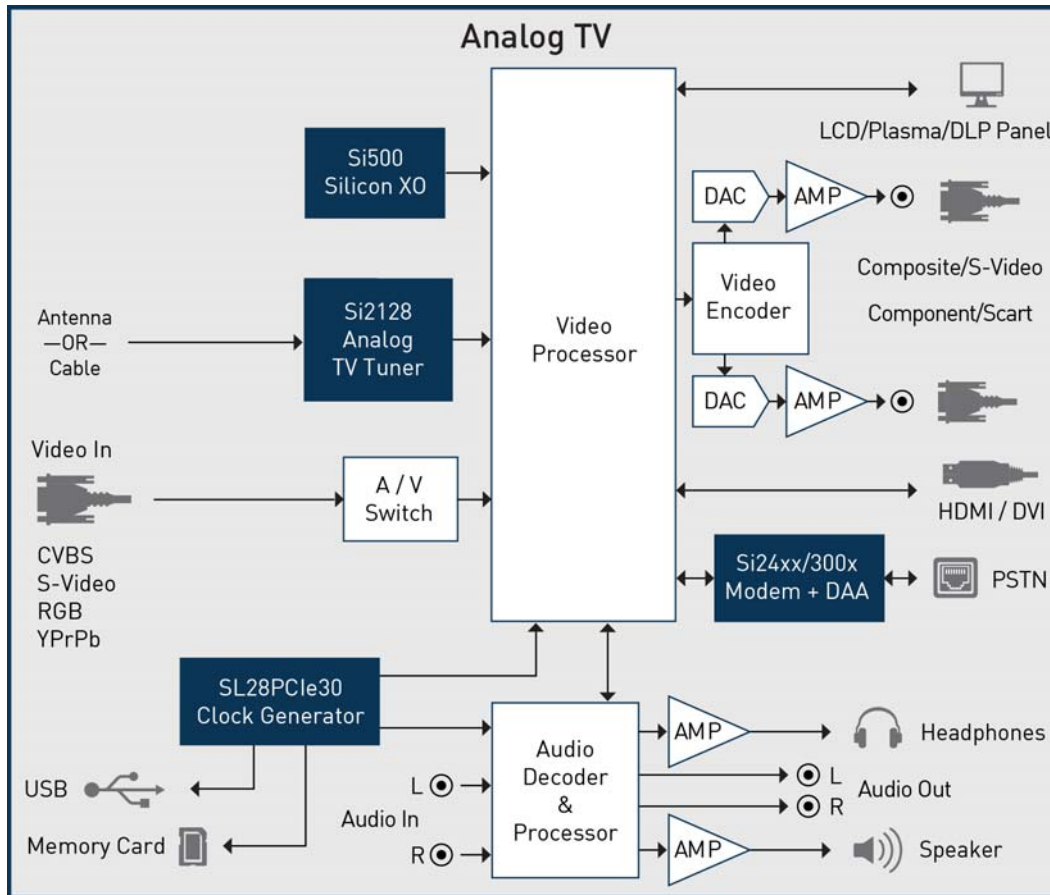

Selection Guide

Part #	Description
Si2128	Worldwide analog TV tuner for NTSC and PAL/SECAM

Pin Assignments

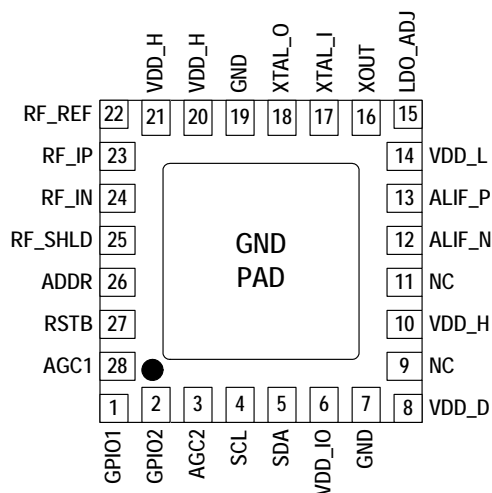

4x4 mm QFN-28 Package Information

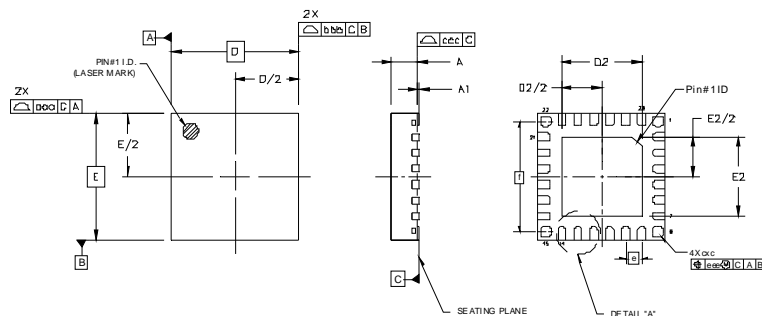

Symbol	Min	Nom	Max	Unit
A	0.80	0.85	0.90	mm
D, E		4.00 BSC		mm
e		0.50 BSC		mm
f		3.50 BSC		mm