

Description

The Si4311 is a fully-integrated FSK CMOS RF receiver that operates in the unlicensed 315 and 433.92 MHz ultra high frequency (UHF) bands. It is designed for high-volume, cost-sensitive RF receiver applications. The chip operates at a carrier frequency of 315 or 433.92 MHz and supports FSK digital modulation with data rates of up to 10 kBaud.

The device leverages Silicon Labs' patented and proven digital low-IF architecture and offers superior sensitivity and interference rejection. The Si4311 can achieve superior sensitivity in the presence of large interference due to its high dynamic range ADCs and digital filters. The digital low-IF architecture also enables superior blocking ability and low intermodulation distortion for robust reception in the presence of wide-band interference.

Digital integration reduces the number of required external components compared to traditional offerings, resulting in a solution that only requires a 16 MHz crystal and passive components allowing a small and compact printed circuit board (PCB) implementation area. The high integration of the Si4311 improves the system manufacturing reliability, improves quality, eases design-in, and minimizes costs.

Features

- Single chip receiver with only six external components
- Selectable 315/433.92 MHz carrier frequency
- Supports FSK modulation
- High sensitivity (-104 dBm @ 5 kBaud)
- Excellent interference rejection
- Selectable IF bandwidths
- Automatic Frequency Centering (AFC)
- Data rates up to 10 kBaud
- Direct battery operation with on-chip low drop out (LDO) voltage regulator
- 16 MHz crystal oscillator support
- 3x3x0.85 mm 20L QFN package (RoHS compliant)
- -40 to +85 °C temperature range

Applications

- Satellite set-top box receivers
- Remote controls, IR replacement/extension
- Garage and gate door openers
- Home automation and security
- Remote keyless entry
- After market alarms
- Telemetry
- Wireless point of sale
- Toys

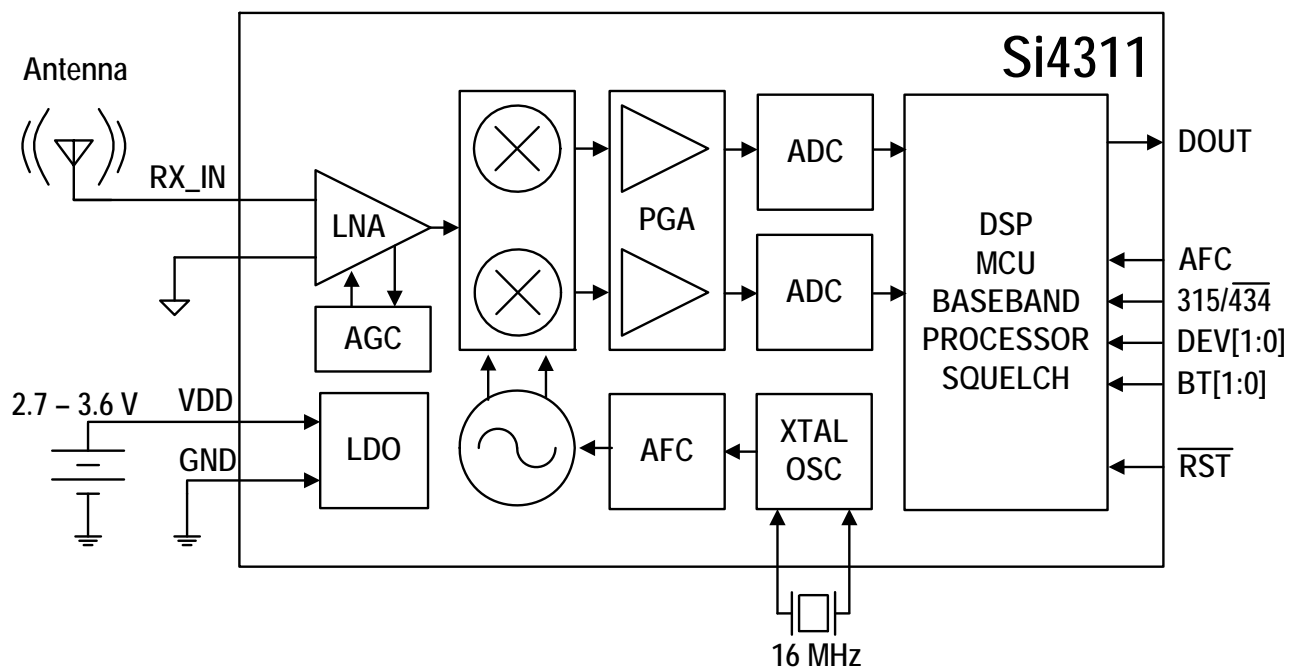

Selected Electrical Specifications

Parameter	Symbol	Test Condition	Min	Typ	Max	Unit
Supply Voltage	V_{DD}		2.7	3.3	3.6	V
Ambient Temperature	T_A		-40	25	85	°C
Supply Current	I_{VDD}		—	20	—	mA
Reset Supply Current	I_{RST}	Reset asserted	—	2	—	μA
Sensitivity @ BER = 10^{-3}		1.0 kBaud, $\Delta f = 50$ kHz, xtal = ± 20 ppm, 315 MHz	—	-104	—	dBm
		10 kBaud, $\Delta f = 50$ kHz, xtal = ± 20 ppm, 315 MHz	—	-101	—	dBm
		1.0 kBaud, $\Delta f = 50$ kHz, xtal = ± 20 ppm, 433.92 MHz	—	-102	—	dBm
		10 kBaud, $\Delta f = 50$ kHz, xtal = ± 20 ppm, 433.92 MHz	—	-100	—	dBm
Data Rate		NRZ	—	—	10	kBaud
Blocking		± 2 MHz, 2.4 kBaud, desired signal is 3 dB above sensitivity, CW interferer level is increased until BER = 10^{-3}	—	65	—	dB
		± 10 MHz, 2.4 kBaud, desired signal is 3 dB above sensitivity, CW interferer level is increased until BER = 10^{-3}	—	70	—	dB
Maximum RF Input Power			—	8	—	dBm
Input IP3		$ f_2 - f_1 = 5$ MHz, high gain mode, desired signal is 3 dB above sensitiv- ity, CW interference levels are increased until BER = 10^{-3}	—	-10	—	dBm
FSK Deviation Input Range			10	—	90	kHz
Crystal Oscillator Frequency			—	16	—	MHz

Pin Package

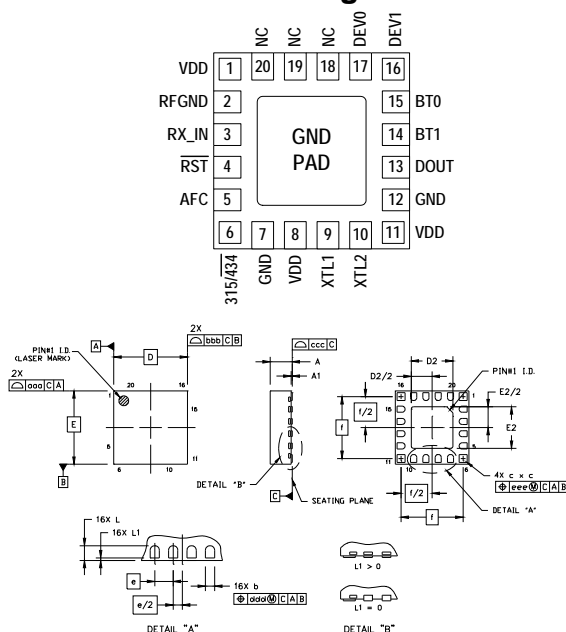

Symbol	Min	Nom	Max
A	0.80	0.85	0.90
A1	0.00	0.02	0.05
b	0.20	0.25	0.30
c	0.27	0.32	0.37
D	3.00 BSC		
D2	1.65	1.70	1.75
e	0.50 BSC		
E	3.00 BSC		
E2	1.65	1.70	1.75

Symbol	Min	Nom	Max
f	2.53 BSC		
L	0.30	0.35	0.40
L1	0.00	—	0.10
aaa	—	—	0.05
bbb	—	—	0.05
ccc	—	—	0.08
ddd	—	—	0.10
eee	—	—	0.10

Notes:

- All dimensions are shown in millimeters (mm) unless otherwise noted.
- Dimensioning and tolerancing per ASME Y14.5M-1994.