

TSM-116-02-S-DV-LC

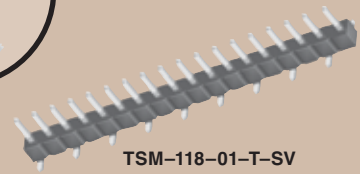
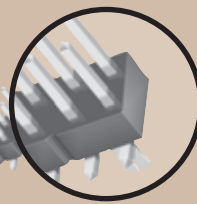

TSM-118-01-T-SV

(2,54 mm) .100"

TSM SERIES

SMT .025" SQ POST HEADER

Mates with:

SSW, SSQ, SSM, BSW, ESW, ESQ, BCS, SLW, CES, HLE, IDSS, IDSD, SMSD, SMSS

SPECIFICATIONS

For complete specifications and recommended PCB layouts see www.samtec.com?TSM

Insulator Material:

Black Liquid Crystal Polymer
Terminal Material: Phosphor Bronze
Plating: Au or Sn over 50µ" (1,27 µm) Ni



Operating Temp Range: -55°C to +105°C with Tin; -55°C to +125°C with Gold

Voltage Rating: 475 VAC -SV/-DV mated with BCS or SSM
RoHS Compliant: Yes
Lead-Free Solderable: Yes

-DH/-SH Lead Coplanarity: (0,15 mm) .006" max (02-36)
-DV/-SV Lead Coplanarity: (0,10 mm) .004" max (02-05) (0,13 mm) .005" max (06-10) (0,15 mm) .006" max (11-36)

AMBIENT TEMP	CURRENT RATING (PER CONTACT)
20°C	7A
40°C	6A
60°C	4A
80°C	3A

TSM	1	NO. PINS PER ROW	LEAD STYLE	PLATING OPTION	ROW OPTION
		02 thru 36			
			<ul style="list-style-type: none"> -01 = .230" (5,84 mm) Post Height (Mates with SSW, BCS, SSM, IDSS, IDSD) -02 = .320" (8,13 mm) Post Height (Mates with SSM -DH) -03 = .420" (10,67 mm) Post Height (For Bottom Mount & Pass Through) -04 = .120" (3,05 mm) Post Height (Mates with SLW, CES, HLE) 	<ul style="list-style-type: none"> -F = Gold flash on post, Matte Tin on tail -L = 10µ" (0,25 µm) Gold on post, Matte Tin on tail -S = 30µ" (0,76 µm) Gold on post, Matte Tin on tail -T = Matte Tin 	

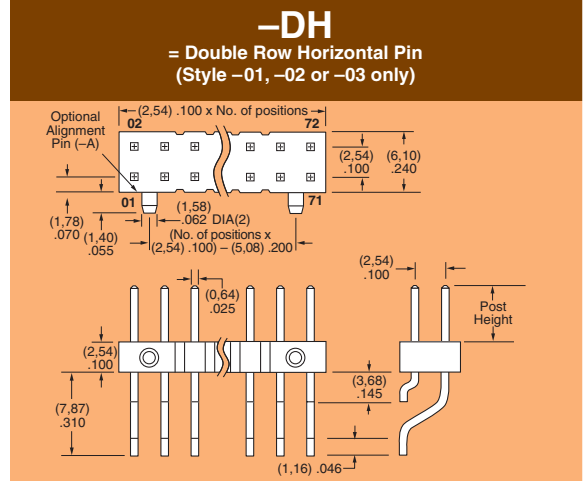
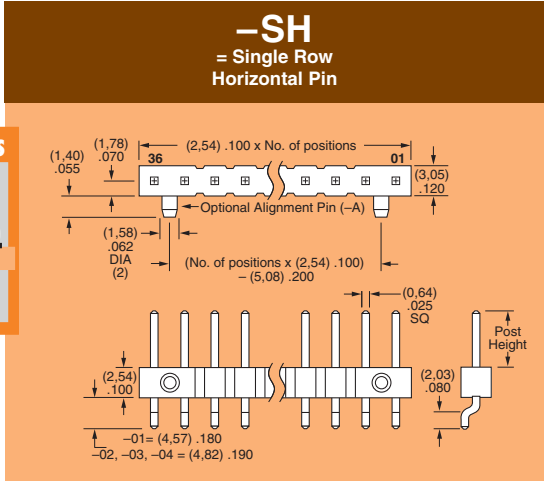
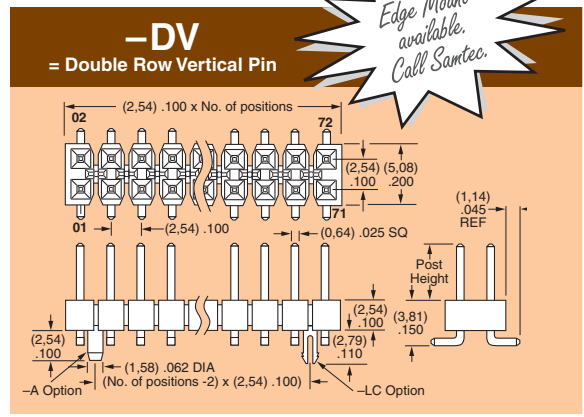
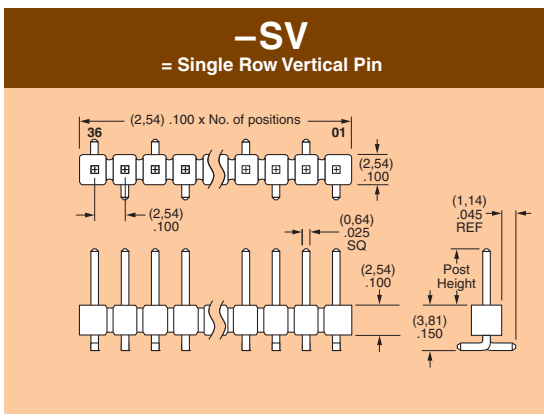

APPLICATIONS

SSM TSM

HORIZONTAL

Note: Other Gold plating options available. Contact Samtec.
Note: Some lengths, styles and options are non-standard, non-returnable.

Due to technical progress, all designs, specifications and components are subject to change without notice.

WWW.SAMTEC.COM

TSM-118-01-L-DH

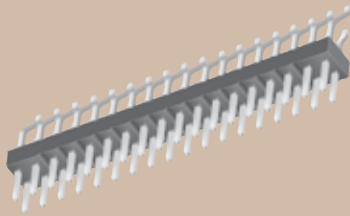

TSM-115-01-T-SH-A

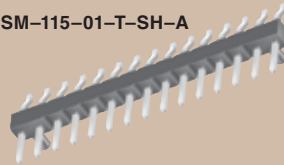

TSM-110-01-T-DV

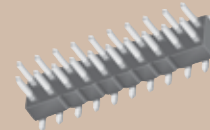

OTHER OPTIONS

-A

= Alignment Pin metal or plastic at Samtec discretion (Not available with -TM or -MT) (02 positions min.) (N/A with -LC)

-K

= (6,50 mm) .256" DIA Polyimide Film Pick & Place Pad (-SH: 4 positions minimum without -TR; 2 & 3 positions available with -TR) (-DH: 4 positions minimum without -TR)

-P

= Plastic Pick & Place Pad (-DV: 4 positions minimum without -TR; 2 & 3 positions available with -TR) (-SH: 4 positions minimum without -TR; 2 & 3 positions available with -TR) (-DH: 5 positions minimum without -TR) (-SV: 4 positions minimum without -TR; 2 & 3 positions available with -TR)

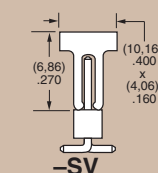

-M

= Metal Pick & Place Pad (4 positions minimum without -TR) (2 & 3 positions available with -TR) Styles -01 & -04 only (N/A with -T plating)

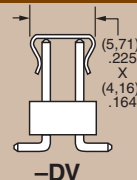

-TR

= Tape & Reel Packaging -SV = 02-22 positions -DV = 02-28 positions -SH = 02-30 positions -DH = 02-29 positions N/A with -MT or -TM

-LC

= Locking Clip (N/A with -TM) (3 positions min.) (N/A with -A) (Manual placement required)

- "XXX" = Polarized Position

TAPE & REEL AVAILABILITY
 No tooling charges.
 Minimum order is the lesser of a full reel quantity or 125 pieces.
 Order any quantity above minimum.
 In-house design, manufacture.
 Quick turn-around.
 Call Samtec for specifications and ordering information.

-TM

= Triple Row Vertical Mixed Technology (Style -01 only)

02 thru 30 positions only

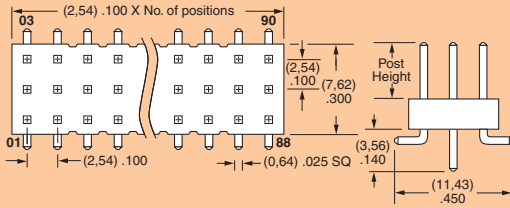

APPLICATION SPECIFIC OPTIONS

Edge Mount and Locking Clips for -SV, Solder Locks for -DH and Shrouds for -DV. Call Samtec.

-MT

= Mixed Technology Pin (Style -01, -02 or -03 only)

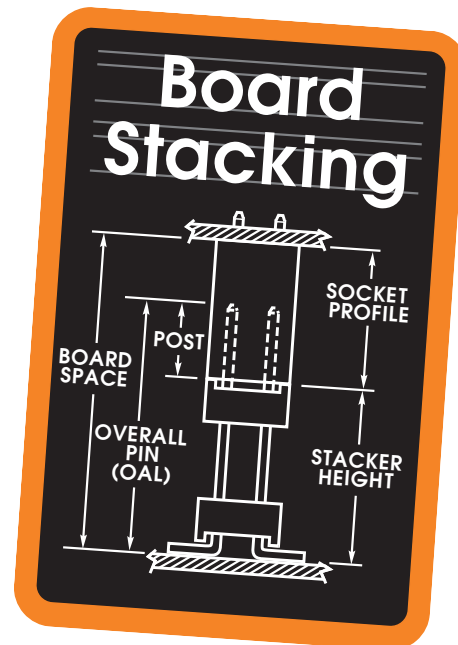
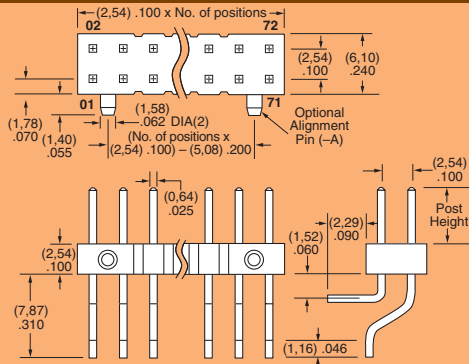

Due to technical progress, all designs, specifications and components are subject to change without notice.

WWW.SAMTEC.COM

SAMTEC USA • Tel: 1-800-SAMTEC-9 or 812-944-6733 SAMTEC NORTHERN CALIFORNIA • Tel: 408-395-5900 SAMTEC SOUTHERN CALIFORNIA • Tel: 1-800-726-8329
 SAMTEC AMERICA LATINA COMERCIO EXTERIOR LTDA • Tel: (+55 31) 3786 3227 SAMTEC UNITED KINGDOM • Tel: 44 01236 739292 SAMTEC GERMANY • Tel: +49 (0) 89 189460-0
 SAMTEC FRANCE • Tel: 33 01 60 95 06 60 SAMTEC ITALY • Tel: 39 039 6890337 SAMTEC NORDIC/BALTIC • Tel: +46-84477280 SAMTEC BENELUX • Tel: 44 01236 739292
 SAMTEC ISRAEL • Tel: 972-3-7526600 SAMTEC INDIA • Tel: +91-80-3272 1612 SAMTEC ASIA PACIFIC • Tel: 65 6745-5955 SAMTEC JAPAN • Tel: 045-475-1385 SAMTEC CHINA • Tel: 86-21-6083 3766
 SAMTEC TAIWAN • Tel: 886-2-2735-6109 SAMTEC HONG KONG • Tel: 852-26904958 SAMTEC KOREA • Tel: 82-31-717-5685 SAMTEC ANZ • Tel: 613 9580 0683