

Synchronous Buck NexFET™ Power Block II

FEATURES

- Half-Bridge Power Block
- 90% system Efficiency at 20A
- Up To 25A Operation
- High Density – 5-mm x 2.5-mm LGA Footprint
- Double Side Cooling Capability
- Ultra Low Profile – 0.48-mm MAX
- Optimized for 5V Gate Drive
- Low Switching Losses
- Low Inductance Package
- RoHS Compliant
- Halogen Free
- Pb-Free Terminal Plating

APPLICATIONS

- Synchronous Buck Converters
 - High Current, Low Duty Cycle Applications
- Multiphase Synchronous Buck Converters
- POL DC-DC Converters

DESCRIPTION

The CSD87588N NexFET™ power block II is a highly optimized design for synchronous buck applications offering high current and high efficiency capability in a small 5-mm x 2.5-mm outline. Optimized for 5V gate drive applications, this product offers an efficient and flexible solution capable of providing a high density power supply when paired with any 5V gate driver from an external controller/driver.

ORDERING INFORMATION

| Device | Package | Media | Qty | Ship |
|-----------|-------------|--------------|------|---------------|
| CSD87588N | 5 x 2.5 LGA | 13-Inch Reel | 2500 | Tape and Reel |

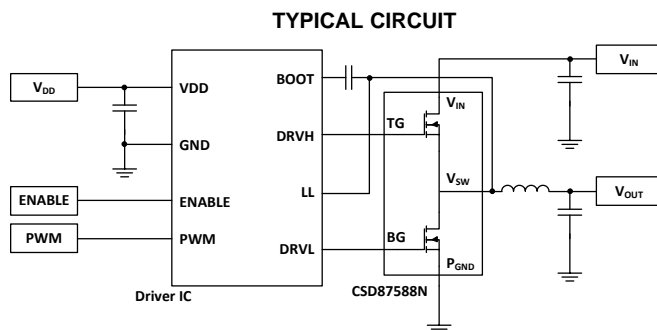
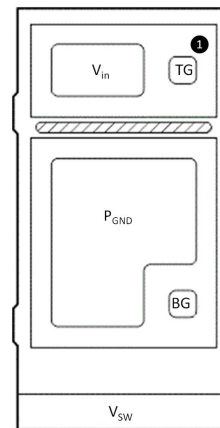

TYPICAL POWER BLOCK EFFICIENCY and POWER LOSS

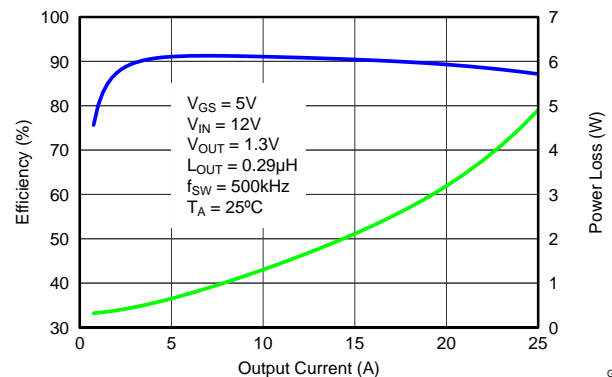

G001



Please be aware that an important notice concerning availability, standard warranty, and use in critical applications of Texas Instruments semiconductor products and disclaimers thereto appears at the end of this data sheet.

NexFET is a trademark of Texas Instruments.

PRODUCTION DATA information is current as of publication date. Products conform to specifications per the terms of the Texas Instruments standard warranty. Production processing does not necessarily include testing of all parameters.



These devices have limited built-in ESD protection. The leads should be shorted together or the device placed in conductive foam during storage or handling to prevent electrostatic damage to the MOS gates.

ABSOLUTE MAXIMUM RATINGS

$T_A = 25^\circ\text{C}$ (unless otherwise noted) ⁽¹⁾

| Parameter | Conditions | VALUE | | UNIT |
|---|--|-------|-----|------------------|
| | | MIN | MAX | |
| Voltage range | V_{IN} to P_{GND} | | 30 | V |
| | V_{SW} to P_{GND} | | 30 | |
| | V_{SW} to P_{GND} (10 ns) | | 32 | |
| | T_G to V_{SW} | -20 | 20 | |
| | B_G to P_{GND} | -20 | 20 | |
| Pulsed Current Rating, I_{DM} ⁽²⁾ | | | 50 | A |
| Power Dissipation, P_D ⁽³⁾ | | | 6 | W |
| Avalanche Energy E_{AS} | Sync FET, $I_D = 45\text{A}$, $L = 0.1\text{mH}$ | | 101 | mJ |
| | Control FET, $I_D = 26\text{A}$, $L = 0.1\text{mH}$ | | 34 | |
| Operating Junction and Storage Temperature Range, T_J , T_{STG} | | -55 | 150 | $^\circ\text{C}$ |

(1) Stresses beyond those listed under Absolute Maximum Ratings may cause permanent damage to the device. These are stress ratings only, and functional operation of the device at these or any other conditions beyond those indicated is not implied. Exposure to absolute-maximum-rated conditions for extended periods may affect device reliability.

(2) Pulse Duration $\leq 50 \mu\text{s}$. Duty cycle ≤ 0.01 .

(3) Device mounted on FR4 material with 1-inch² (6.45-cm²) Cu.

RECOMMENDED OPERATING CONDITIONS

$T_A = 25^\circ$ (unless otherwise noted)

| Parameter | Conditions | MIN | MAX | UNIT |
|--------------------------------|-----------------------------------|-----|------|------------------|
| Gate Drive Voltage, V_{GS} | | 4.5 | 16 | V |
| Input Supply Voltage, V_{IN} | | | 24 | V |
| Switching Frequency, f_{SW} | $C_{BST} = 0.1 \mu\text{F}$ (min) | 200 | 1500 | kHz |
| Operating Current | No Airflow | | 25 | A |
| | With Airflow | | 30 | A |
| | With Airflow + Heat Sink | | 35 | A |
| Operating Temperature, T_J | | | 125 | $^\circ\text{C}$ |

POWER BLOCK PERFORMANCE

$T_A = 25^\circ$ (unless otherwise noted)

| Parameter | Conditions | MIN | TYP | MAX | UNIT |
|--|---|-----|-----|-----|---------------|
| Power Loss, P_{LOSS} ⁽¹⁾ | $V_{IN} = 12\text{V}$, $V_{GS} = 5\text{V}$, $V_{OUT} = 1.3\text{V}$, $I_{OUT} = 15\text{A}$, $f_{SW} = 500\text{kHz}$, $L_{OUT} = 0.29 \mu\text{H}$, $T_J = 25^\circ\text{C}$ | | 2.1 | | W |
| V_{IN} Quiescent Current, I_{QVIN} | T_G to $T_{GR} = 0\text{V}$ B_G to $P_{GND} = 0\text{V}$ | | 10 | | μA |

(1) Measurement made with six 10 μF (TDK C3216X5R1C106KT or equivalent) ceramic capacitors placed across V_{IN} to P_{GND} pins and using a high current 5V driver IC.

THERMAL INFORMATION

 $T_A = 25^\circ\text{C}$ (unless otherwise stated)

| THERMAL METRIC | | MIN | TYP | MAX | UNIT |
|-----------------|---|-----|-----|------|------|
| $R_{\theta JA}$ | Junction to ambient thermal resistance (Min Cu) ⁽¹⁾ | | | 170 | °C/W |
| | Junction to ambient thermal resistance (Max Cu) ⁽²⁾⁽¹⁾ | | | 70 | |
| $R_{\theta JC}$ | Junction to case thermal resistance (Top of package) ⁽¹⁾ | | | 3.7 | |
| | Junction to case thermal resistance (P_{GND} Pin) ⁽¹⁾ | | | 1.25 | |

- (1) $R_{\theta JC}$ is determined with the device mounted on a 1-inch² (6.45-cm²), 2 oz. (0.071-mm thick) Cu pad on a 1.5-inch x 1.5-inch (3.81-cm x 3.81-cm), 0.06-inch (1.52-mm) thick FR4 board. $R_{\theta JC}$ is specified by design while $R_{\theta JA}$ is determined by the user's board design.
- (2) Device mounted on FR4 material with 1-inch² (6.45-cm²) Cu.

ELECTRICAL CHARACTERISTICS

T_A = 25°C (unless otherwise stated)

| PARAMETER | | TEST CONDITIONS | Q1 Control FET | | | Q2 Sync FET | | | UNIT |
|--------------------------------|---|--|----------------|------|------|-------------|------|------|------|
| | | | MIN | TYP | MAX | MIN | TYP | MAX | |
| Static Characteristics | | | | | | | | | |
| B _V DSS | Drain to Source Voltage | V _{GS} = 0V, I _{DS} = 250μA | 30 | | | 30 | | | V |
| I _{DSS} | Drain to Source Leakage Current | V _{GS} = 0V, V _{DS} = 24V | | | 1 | | | 1 | μA |
| I _{GSS} | Gate to Source Leakage Current | V _{DS} = 0V, V _{GS} = 20 | | | 100 | | | 100 | nA |
| V _{GS(th)} | Gate to Source Threshold Voltage | V _{DS} = V _{GS} , I _{DS} = 250μA | 1.1 | | 1.9 | 1.1 | | 1.9 | V |
| R _{DS(on)} | Drain to Source On Resistance | V _{GS} = 4.5V, I _{DS} = 15A | | 10.4 | 12.5 | | 3.5 | 4.2 | mΩ |
| | | V _{GS} = 10V, I _{DS} = 15A | | 8.0 | 9.6 | | 2.9 | 3.5 | |
| g _{fs} | Transconductance | V _{DS} = 10V, I _{DS} = 15A | | 43 | | | 93 | | S |
| Dynamic Characteristics | | | | | | | | | |
| C _{ISS} | Input Capacitance ⁽¹⁾ | V _{GS} = 0V, V _{DS} = 15V, f = 1MHz | | 566 | 736 | | 2310 | 3000 | pF |
| C _{OSS} | Output Capacitance ⁽¹⁾ | | | 341 | 444 | | 682 | 887 | pF |
| C _{RSS} | Reverse Transfer Capacitance ⁽¹⁾ | | | 10.3 | 13.4 | | 62 | 80.4 | pF |
| R _G | Series Gate Resistance ⁽¹⁾ | | | 1.2 | 2.4 | | 1.1 | 2.2 | Ω |
| Q _g | Gate Charge Total (4.5V) ⁽¹⁾ | V _{DS} = 15V, I _{DS} = 15A | | 3.2 | 4.1 | | 13.7 | 17.9 | nC |
| Q _{gd} | Gate Charge - Gate to Drain | | | 0.7 | | | 4.3 | | nC |
| Q _{gs} | Gate Charge - Gate to Source | | | 1.4 | | | 4.3 | | nC |
| Q _{g(th)} | Gate Charge at V _{th} | | | 0.8 | | | 2.8 | | nC |
| Q _{OSS} | Output Charge | V _{DD} = 12V, V _{GS} = 0V | | 7.0 | | | 18.6 | | nC |
| t _{d(on)} | Turn On Delay Time | V _{DS} = 15V, V _{GS} = 4.5V, I _{DS} = 15A, R _G = 2Ω | | 7.3 | | | 12.1 | | ns |
| t _r | Rise Time | | | 31.6 | | | 36.7 | | ns |
| t _{d(off)} | Turn Off Delay Time | | | 10.2 | | | 20.1 | | ns |
| t _f | Fall Time | | | 5.0 | | | 6.3 | | ns |
| Diode Characteristics | | | | | | | | | |
| V _{SD} | Diode Forward Voltage | I _{DS} = 15A, V _{GS} = 0V | | 0.85 | | | 0.78 | | V |
| Q _{rr} | Reverse Recovery Charge | V _{dd} = 15V, I _F = 15A, di/dt = 300A/μs | | 12.5 | | | 26.7 | | nC |
| t _{rr} | Reverse Recovery Time | | | 16 | | | 23 | | ns |

(1) Specified by design

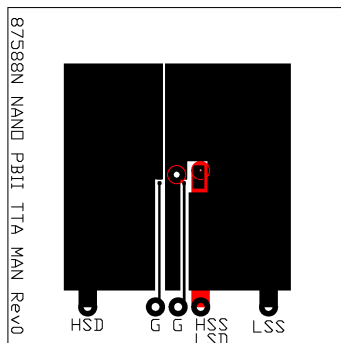

Max R_{θJA} = 70°C/W
when mounted on
1 inch² (6.45 cm²) of 2-
oz. (0.071-mm thick)
Cu.

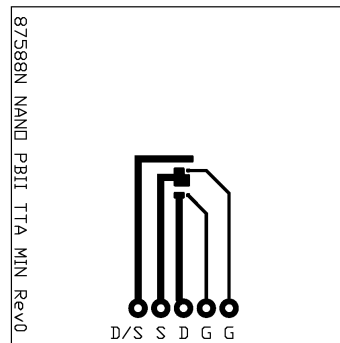

Max R_{θJA} = 170°C/W
when mounted on
minimum pad area of
2-oz. (0.071-mm thick)
Cu.

TYPICAL POWER BLOCK DEVICE CHARACTERISTICS

$T_J = 125^\circ\text{C}$, unless stated otherwise.

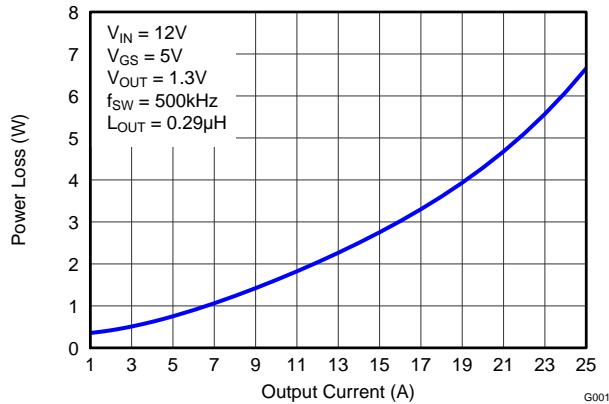

Figure 1. Power Loss vs Output Current

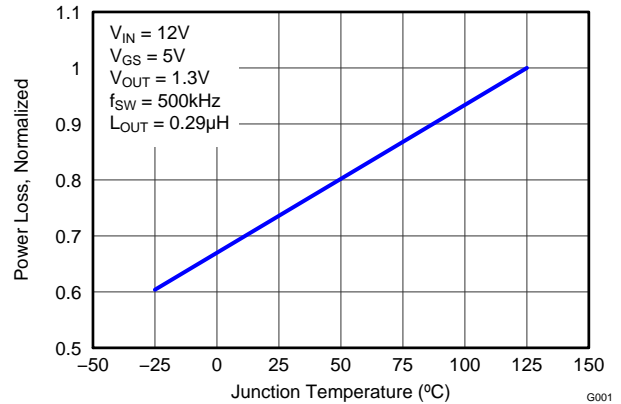

Figure 2. Normalized Power Loss vs Temperature

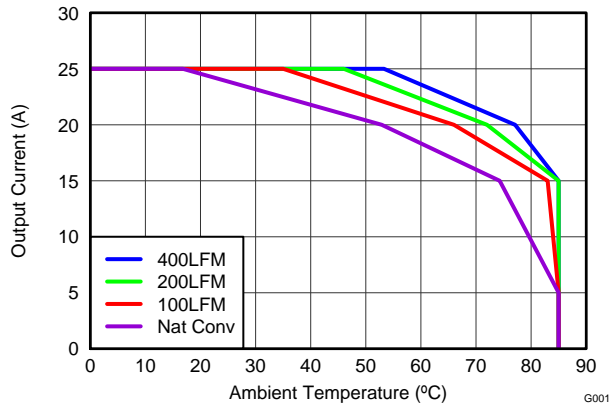

Figure 3. Safe Operating Area – PCB Horizontal Mount (1)

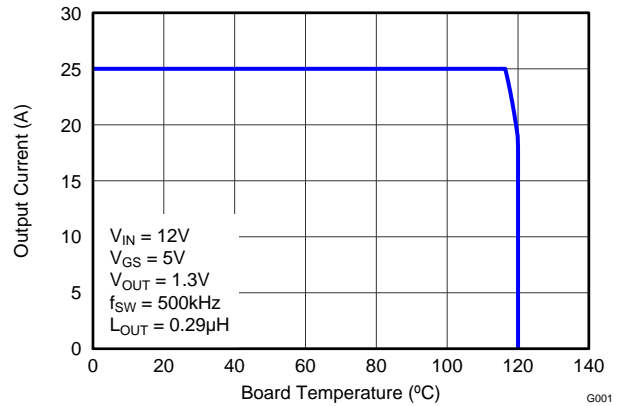

Figure 4. Typical Safe Operating Area(1)

(1) The Typical Power Block System Characteristic curves are based on measurements made on a PCB design with dimensions of 4.0" (W) x 3.5" (L) x 0.062" (H) and 6 copper layers of 1 oz. copper thickness. See Application Section for detailed explanation.

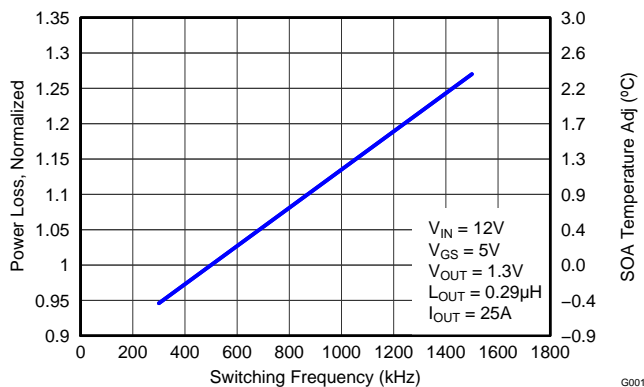

Figure 5. Normalized Power Loss vs Switching Frequency

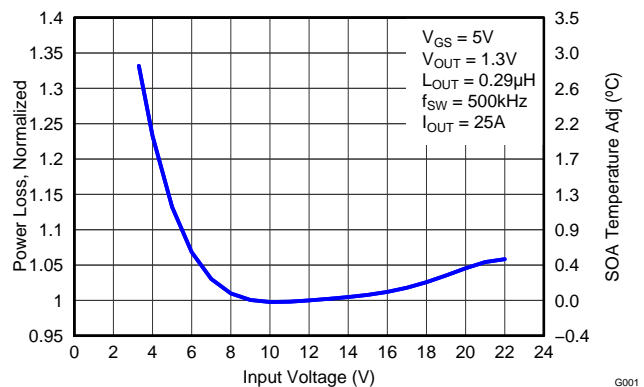

Figure 6. Normalized Power Loss vs Input Voltage

TYPICAL POWER BLOCK DEVICE CHARACTERISTICS (continued)

T_J = 125°C, unless stated otherwise.

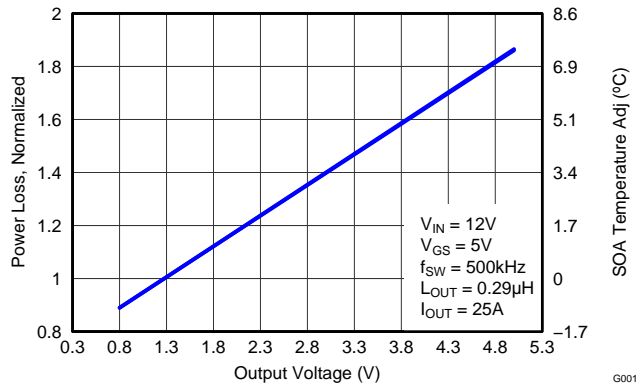

Figure 7. Normalized Power Loss vs. Output Voltage

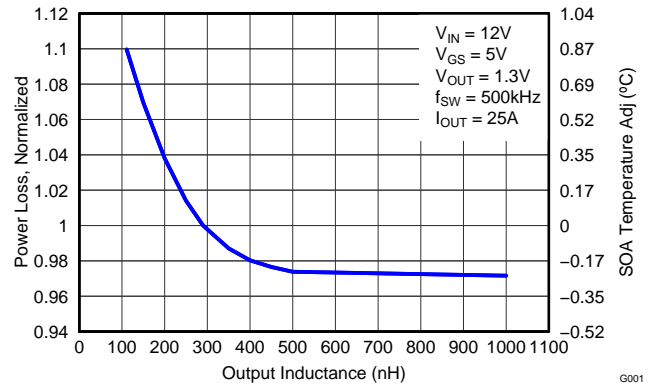

Figure 8. Normalized Power Loss vs. Output Inductance

TYPICAL POWER BLOCK MOSFET CHARACTERISTICS

$T_A = 25^\circ\text{C}$, unless stated otherwise.

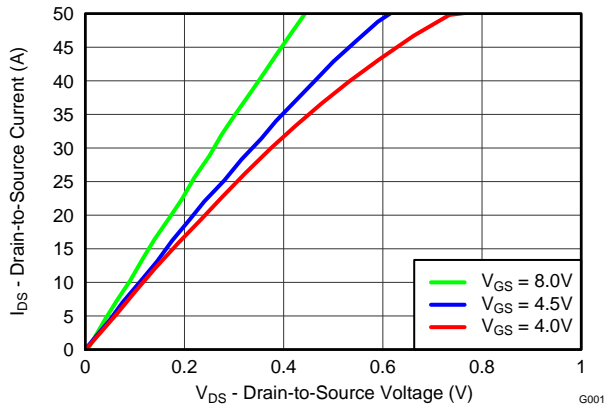

Figure 9. Control MOSFET Saturation

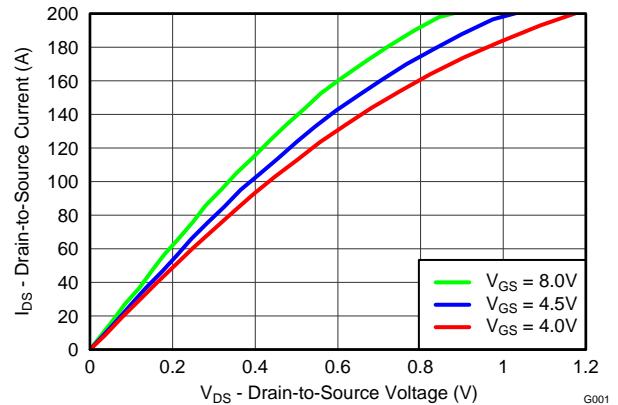

Figure 10. Sync MOSFET Saturation

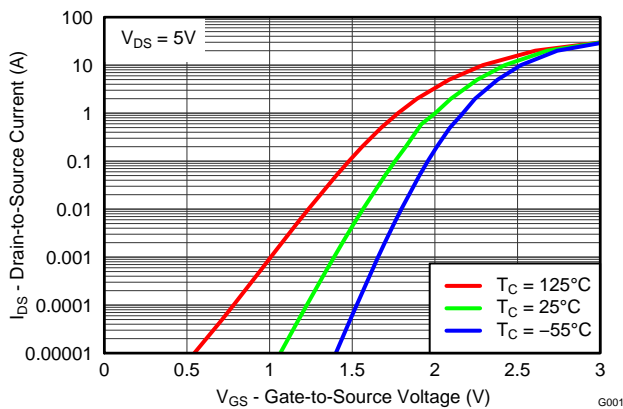

Figure 11. Control MOSFET Transfer

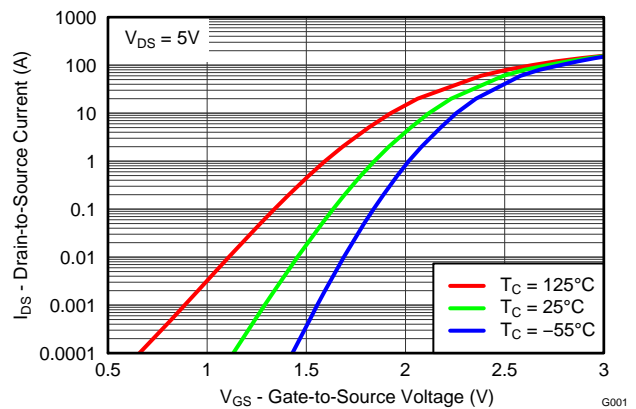

Figure 12. Sync MOSFET Transfer

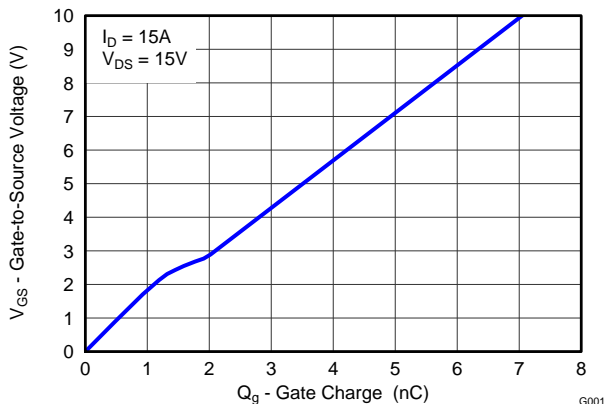

Figure 13. Control MOSFET Gate Charge

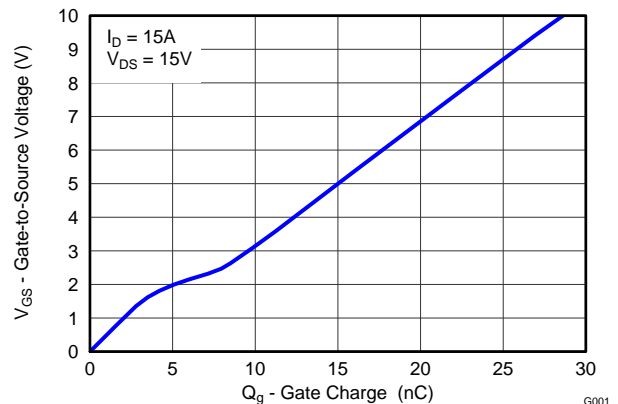

Figure 14. Sync MOSFET Gate Charge

TYPICAL POWER BLOCK MOSFET CHARACTERISTICS (continued)

T_A = 25°C, unless stated otherwise.

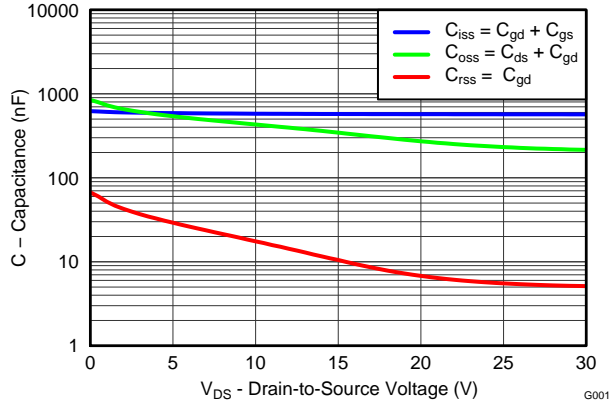

Figure 15. Control MOSFET Capacitance

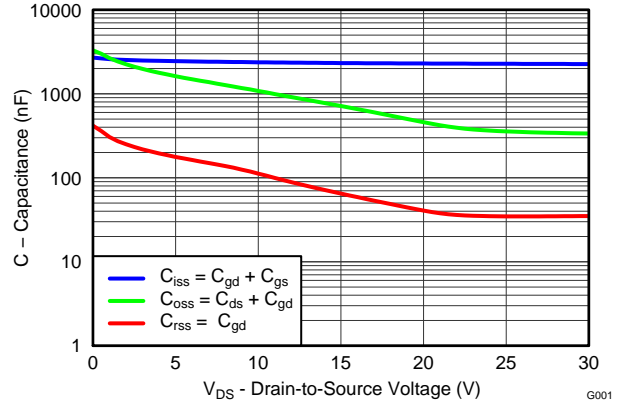

Figure 16. Sync MOSFET Capacitance

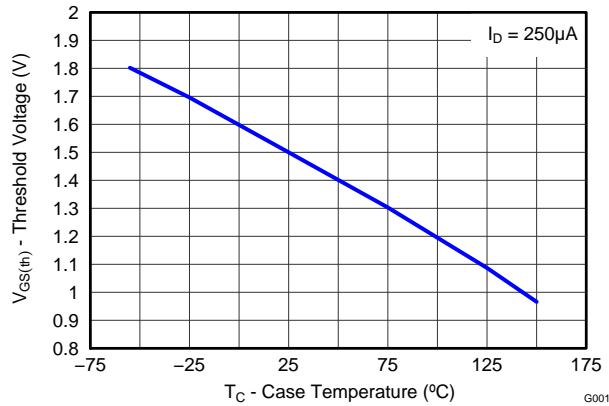

Figure 17. Control MOSFET V_{GS(th)}

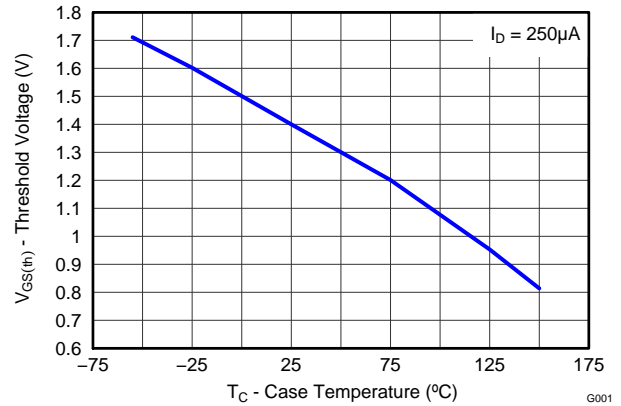

Figure 18. Sync MOSFET V_{GS(th)}

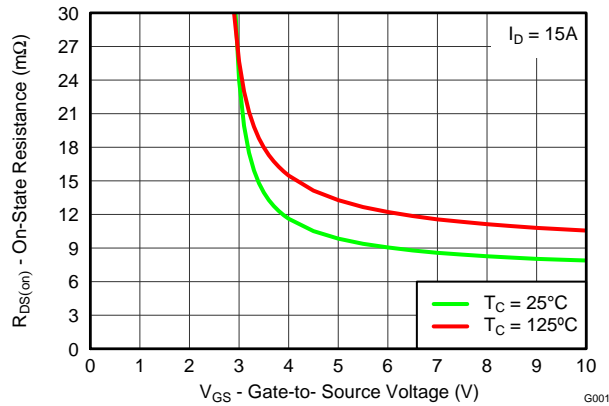

Figure 19. Control MOSFET R_{DS(on)} vs V_{GS}

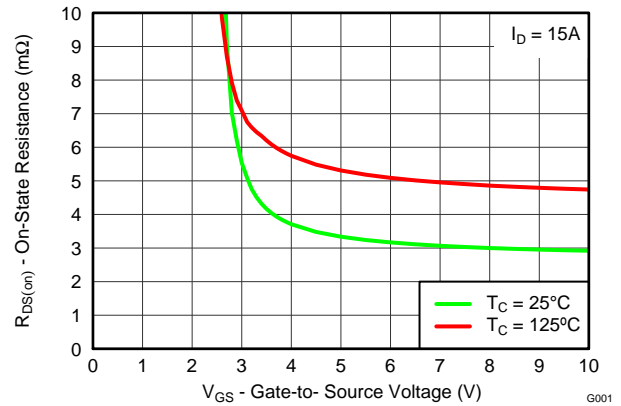

Figure 20. Sync MOSFET R_{DS(on)} vs V_{GS}

TYPICAL POWER BLOCK MOSFET CHARACTERISTICS (continued)

T_A = 25°C, unless stated otherwise.

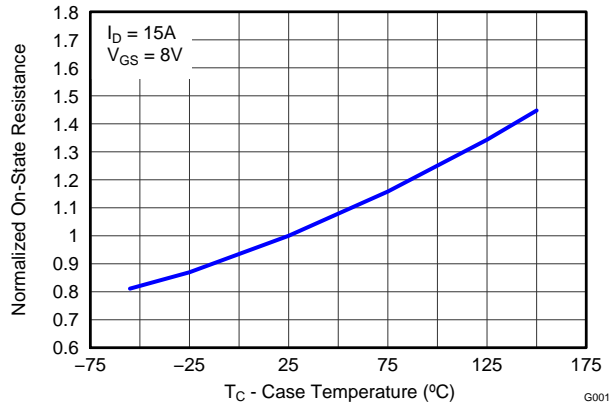

Figure 21. Control MOSFET Normalized R_{DS(on)}

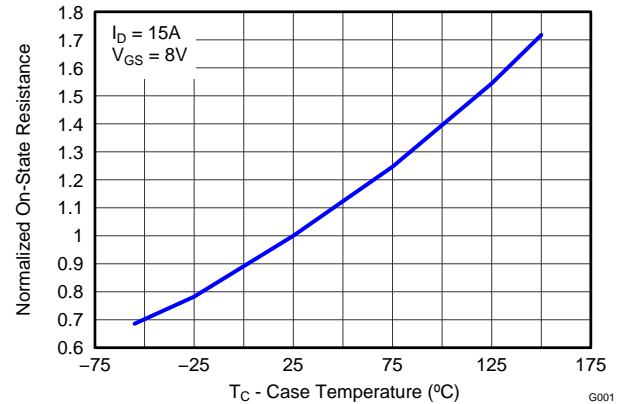

Figure 22. Sync MOSFET Normalized R_{DS(on)}

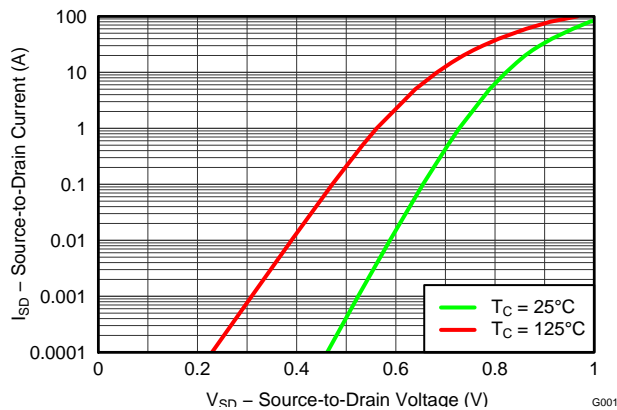

Figure 23. Control MOSFET Body Diode

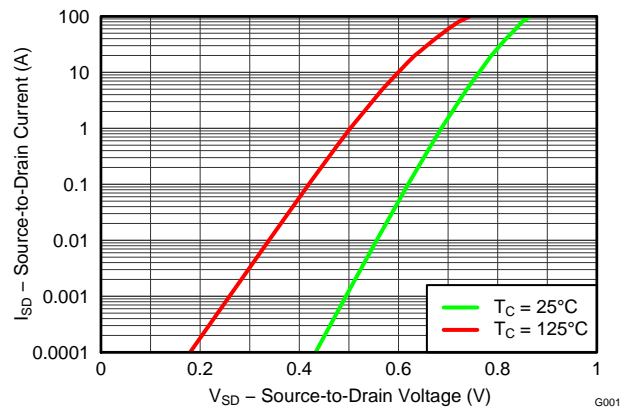

Figure 24. Sync MOSFET Body Diode

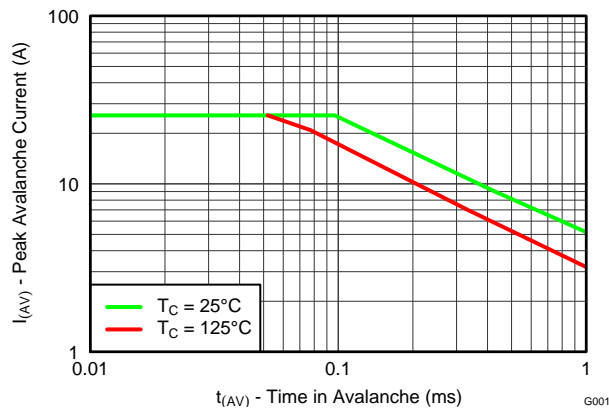

Figure 25. Control MOSFET Unclamped Inductive Switching

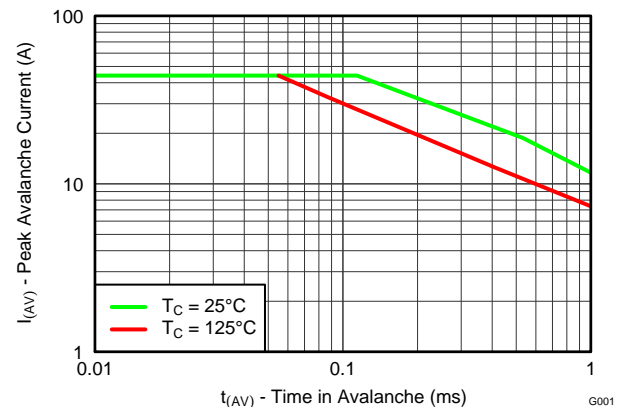

Figure 26. Sync MOSFET Unclamped Inductive Switching

The CSD87588N NexFET™ power block is an optimized design for synchronous buck applications using 5V gate drive. The Control FET and Sync FET silicon are parametrically tuned to yield the lowest power loss and highest system efficiency. As a result, a new rating method is needed which is tailored towards a more systems centric environment. System level performance curves such as Power Loss, Safe Operating Area, and normalized graphs allow engineers to predict the product performance in the actual application.

Power Loss Curves

MOSFET centric parameters such as $R_{DS(ON)}$ and Q_{gd} are needed to estimate the loss generated by the devices. In an effort to simplify the design process for engineers, Texas Instruments has provided measured power loss performance curves. Figure 1 plots the power loss of the CSD87588N as a function of load current. This curve is measured by configuring and running the CSD87588N as it would be in the final application (see Figure 27). The measured power loss is the CSD87588N loss and consists of both input conversion loss and gate drive loss. Equation 1 is used to generate the power loss curve.

$$(V_{IN} \times I_{IN}) + (V_{DD} \times I_{DD}) - (V_{SW_AVG} \times I_{OUT}) = \text{Power Loss} \quad (1)$$

The power loss curve in Figure 1 is measured at the maximum recommended junction temperatures of 125°C under isothermal test conditions.

Safe Operating Curves (SOA)

The SOA curves in the CSD87588N data sheet provides guidance on the temperature boundaries within an operating system by incorporating the thermal resistance and system power loss. Figure 3 to Figure 4 outline the temperature and airflow conditions required for a given load current. The area under the curve dictates the safe operating area. All the curves are based on measurements made on a PCB design with dimensions of 4" (W) x 3.5" (L) x 0.062" (T) and 6 copper layers of 1 oz. copper thickness.

Normalized Curves

The normalized curves in the CSD87588N data sheet provides guidance on the Power Loss and SOA adjustments based on their application specific needs. These curves show how the power loss and SOA boundaries will adjust for a given set of systems conditions. The primary Y-axis is the normalized change in power loss and the secondary Y-axis is the change in system temperature required in order to comply with the SOA curve. The change in power loss is a multiplier for the Power Loss curve and the change in temperature is subtracted from the SOA curve.

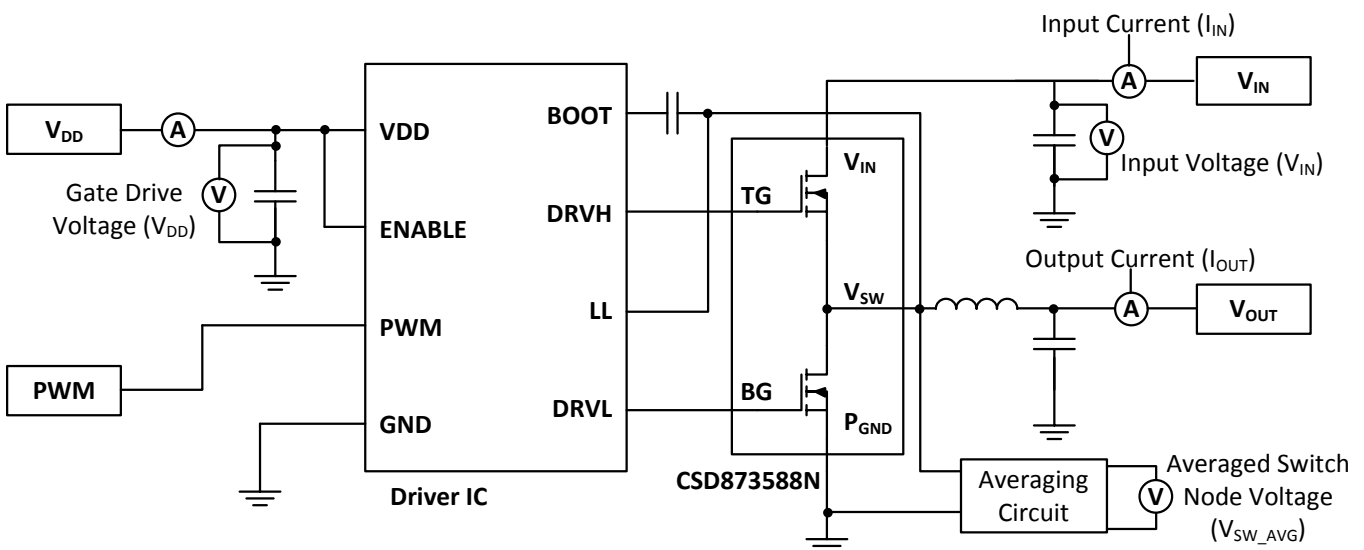

Figure 27. Typical Application

Calculating Power Loss and SOA

The user can estimate product loss and SOA boundaries by arithmetic means (see Design Example). Though the Power Loss and SOA curves in this data sheet are taken for a specific set of test conditions, the following procedure will outline the steps the user should take to predict product performance for any set of system conditions.

Design Example

Operating Conditions:

- Output Current = 15A
- Input Voltage = 7V
- Output Voltage = 1V
- Switching Frequency = 800kHz
- Inductor = 0.2μH

Calculating Power Loss

- Power Loss at 15A = 2.75W (Figure 1)
- Normalized Power Loss for input voltage ≈ 1.03 (Figure 6)
- Normalized Power Loss for output voltage ≈ 0.94 (Figure 7)
- Normalized Power Loss for switching frequency ≈ 1.08 (Figure 5)
- Normalized Power Loss for output inductor ≈ 1.03 (Figure 8)
- **Final calculated Power Loss = 2.75W x 1.05 x 0.95 x 1.05 x 1.05 ≈ 3.02W**

Calculating SOA Adjustments

- SOA adjustment for input voltage ≈ 0.3°C (Figure 6)
- SOA adjustment for output voltage ≈ -0.5°C (Figure 7)
- SOA adjustment for switching frequency ≈ 0.7°C (Figure 5)
- SOA adjustment for output inductor ≈ 0.3°C (Figure 8)
- **Final calculated SOA adjustment = 0.3 + (-0.5) + 0.7 + 0.3 ≈ 0.8°C**

In the design example above, the estimated power loss of the CSD87588N would increase to 3.02W. In addition, the maximum allowable board and/or ambient temperature would have to decrease by 0.8°C. Figure 28 graphically shows how the SOA curve would be adjusted accordingly.

1. Start by drawing a horizontal line from the application current to the SOA curve.
2. Draw a vertical line from the SOA curve intercept down to the board/ambient temperature.
3. Adjust the SOA board/ambient temperature by subtracting the temperature adjustment value.

In the design example, the SOA temperature adjustment yields a reduction in allowable board/ambient temperature of 0.8°C. In the event the adjustment value is a negative number, subtracting the negative number would yield an increase in allowable board/ambient temperature.

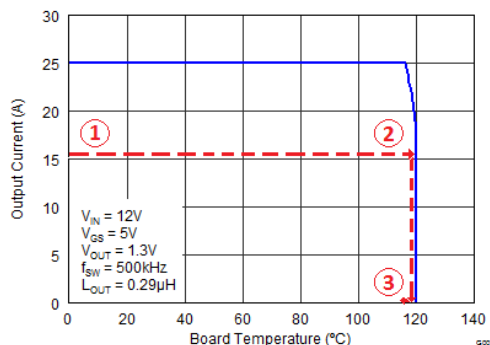

Figure 28. Power Block SOA

RECOMMENDED PCB DESIGN OVERVIEW

There are two key system-level parameters that can be addressed with a proper PCB design: Electrical and Thermal performance. Properly optimizing the PCB layout will yield maximum performance in both areas. A brief description on how to address each parameter is provided.

Electrical Performance

The CSD87588N has the ability to switch voltages at rates greater than 10kV/ μ s. Special care must be then taken with the PCB layout design and placement of the input capacitors, inductor, and output capacitors.

- The placement of the input capacitors relative to VIN and PGND pins of CSD87588N device should have the highest priority during the component placement routine. It is critical to minimize these node lengths. As such, ceramic input capacitors need to be placed as close as possible to the VIN and PGND pins (see Figure 5). The example in Figure 5 uses 1x10nF 0402 25V and 4 x 10 μ F 1206 25V ceramic capacitors (TDK Part # C3216X5R1C106KT or equivalent). Notice there are ceramic capacitors on both sides of the board with an appropriate amount of vias interconnecting both layers. In terms of priority of placement next to the Power Stage C21, C5, C8, C19, and C18 should follow in order.
- The switching node of the output inductor should be placed relatively close to the Power Block II CSD87588N VSW pins. Minimizing the VSW node length between these two components will reduce the PCB conduction losses and actually reduce the switching noise level. see Figure 29 ⁽¹⁾

(1) Keong W. Kam, David Pommerenke, "EMI Analysis Methods for Synchronous Buck Converter EMI Root Cause Analysis", University of Missouri – Rolla

Thermal Performance

The CSD87588N has the ability to utilize the PGND planes as the primary thermal path. As such, the use of thermal vias is an effective way to pull away heat from the device and into the system board. Concerns of solder voids and manufacturability problems can be addressed by the use of three basic tactics to minimize the amount of solder attach that will wick down the via barrel:

- Intentionally space out the vias from each other to avoid a cluster of holes in a given area.
- Use the smallest drill size allowed in your design. The example in Figure 29 uses vias with a 10 mil drill hole and a 16 mil capture pad.
- Tent the opposite side of the via with solder-mask.

In the end, the number and drill size of the thermal vias should align with the end user's PCB design rules and manufacturing capabilities.

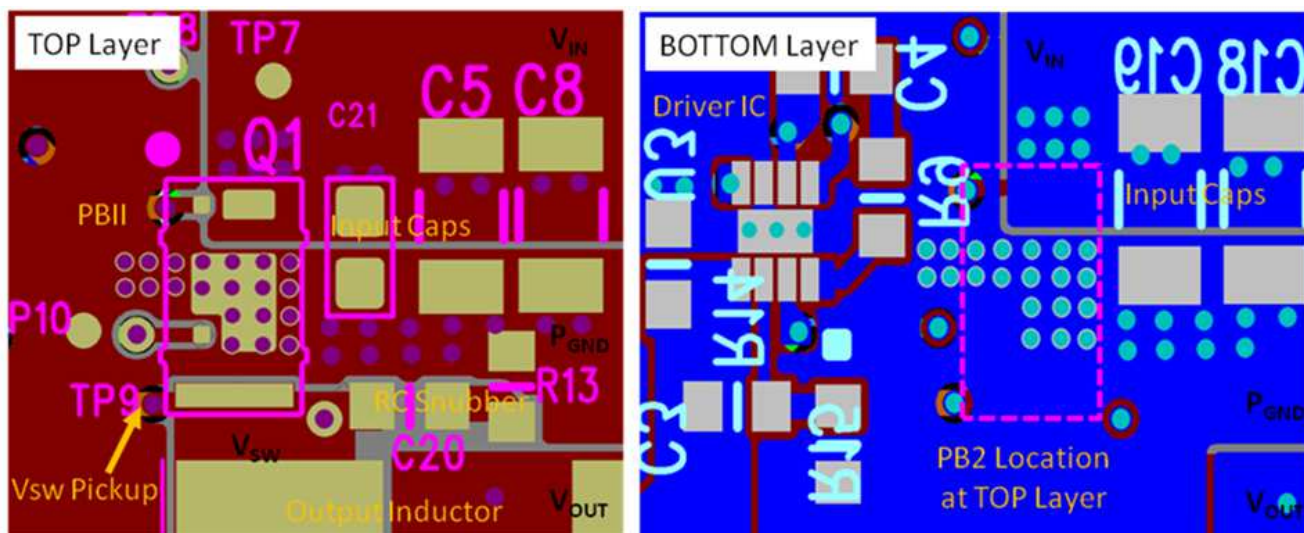

Figure 29. Recommended PCB Layout (Top Down View)

MECHANICAL DATA

CSD87588N Package Dimensions

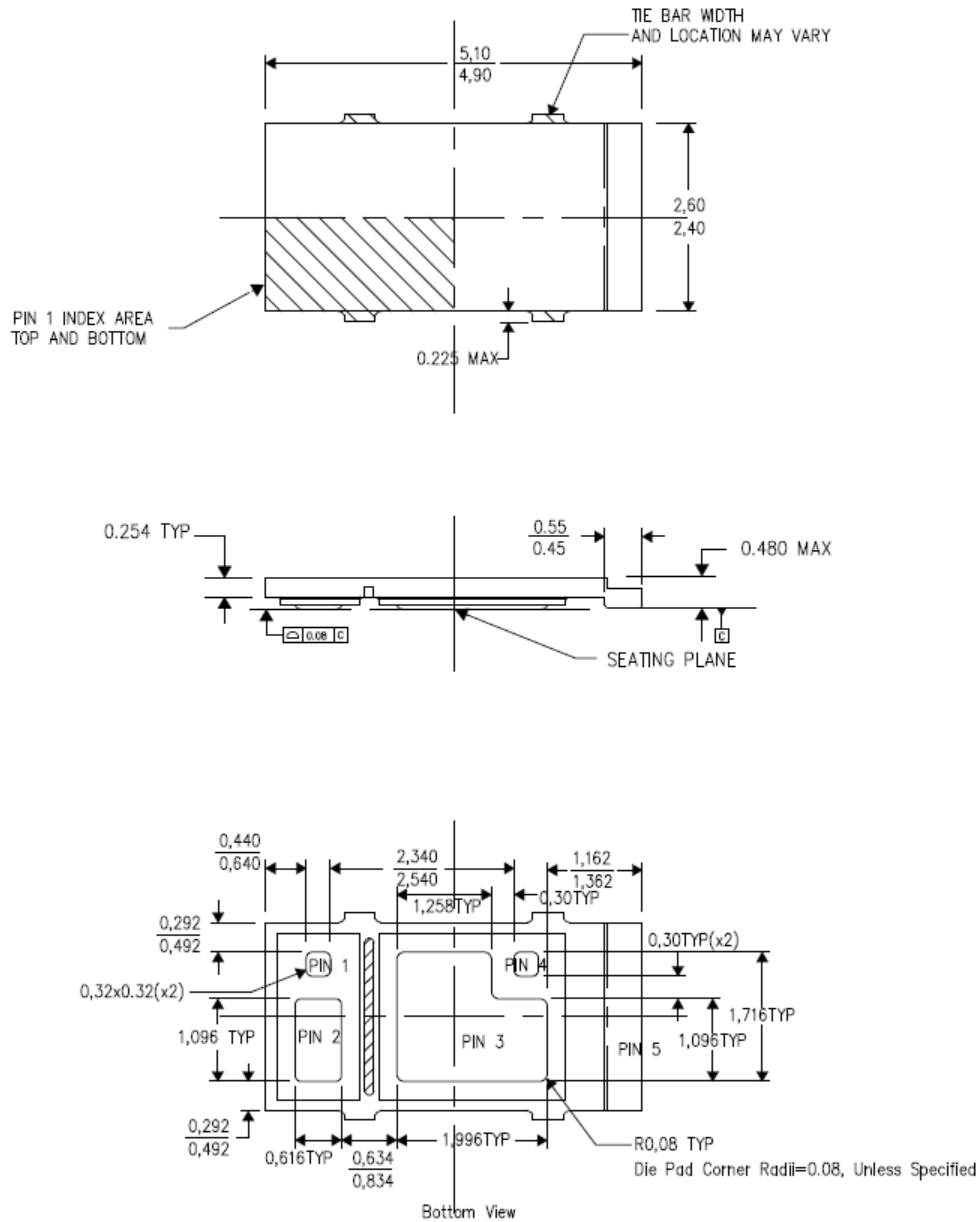
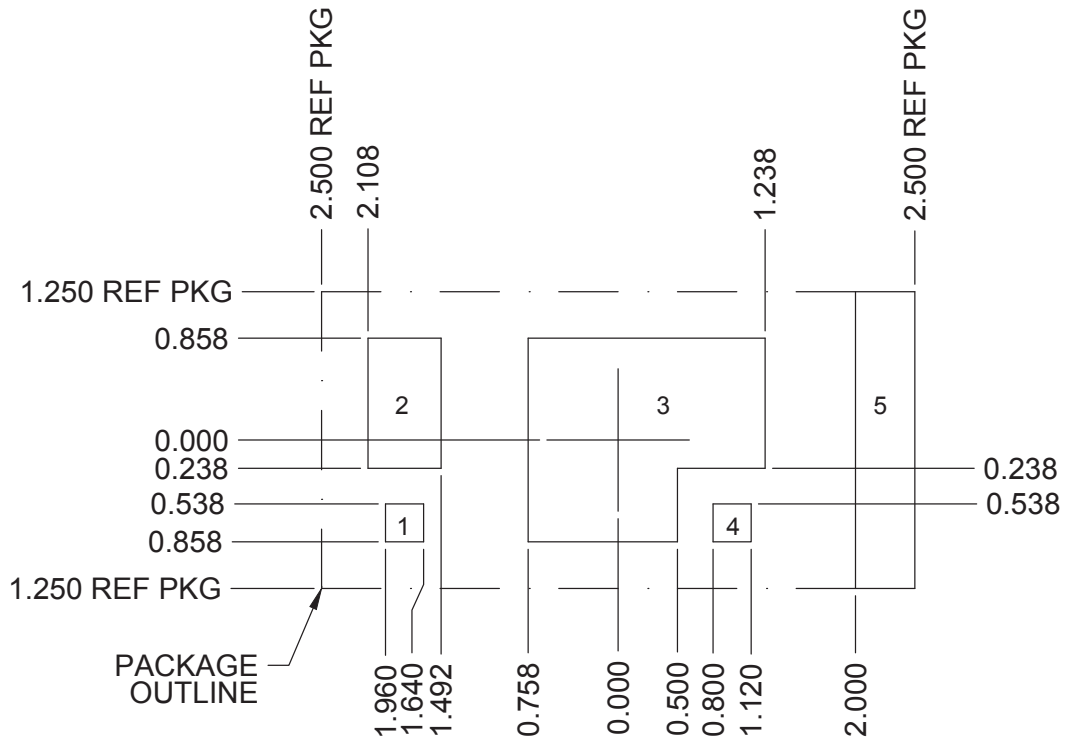

Table 1. Pin Configuration

| Position | Designation |
|----------|------------------|
| Pin 1 | TG |
| Pin 2 | V _{IN} |
| Pin 3 | P _{GND} |
| Pin 4 | BG |
| Pin 5 | V _{SW} |

Land Pattern Recommendation



Stencil Recommendation (100 μm)

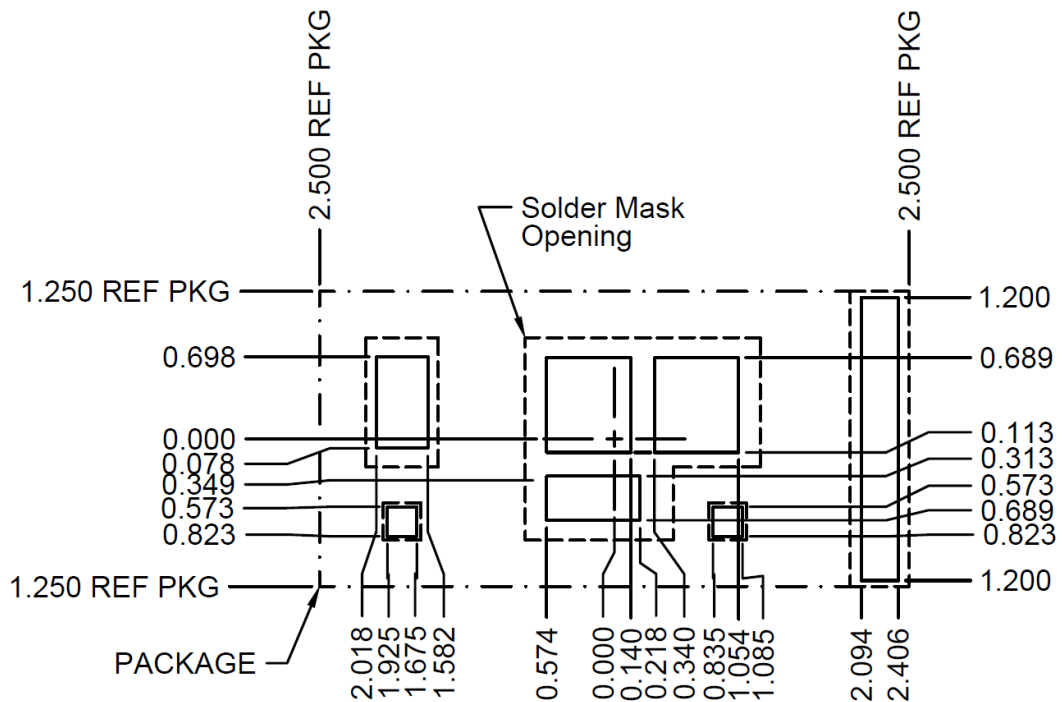

Stencil Recommendation (125 µm)

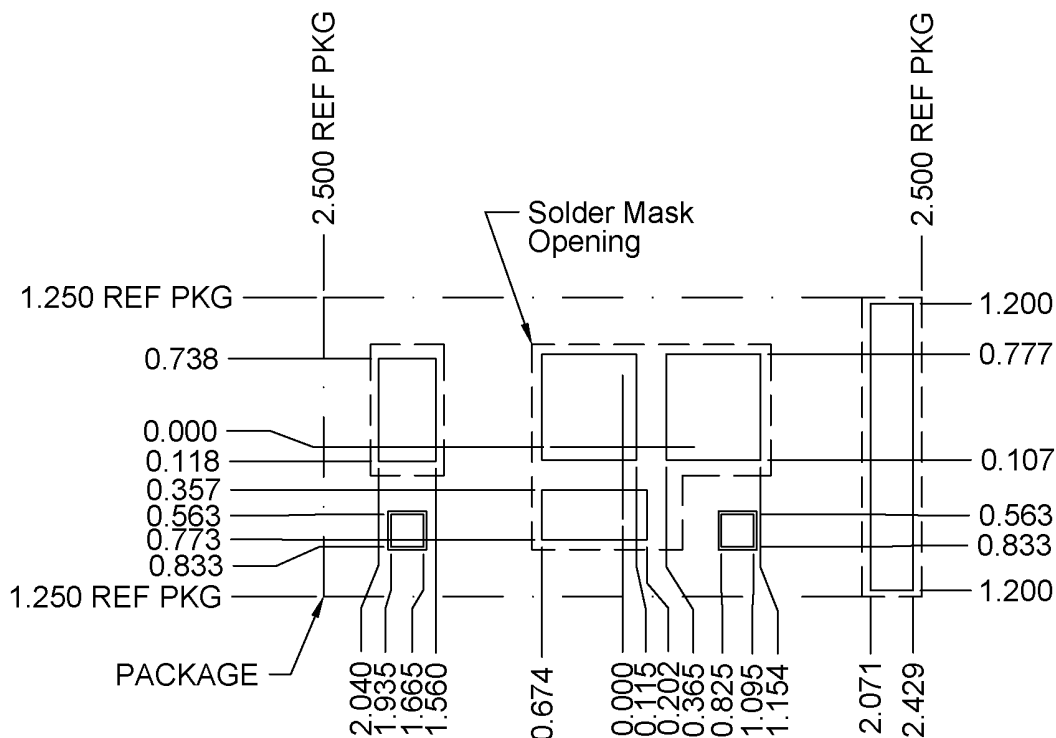

For recommended circuit layout for PCB designs, see application note [SLPA005](#) – *Reducing Ringing Through PCB Layout Techniques*.

Pin Drawing



CSD87588N Embossed Carrier Tape Dimensions

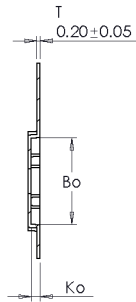

SECTION Y-Y
SCALE 3.5 : 1

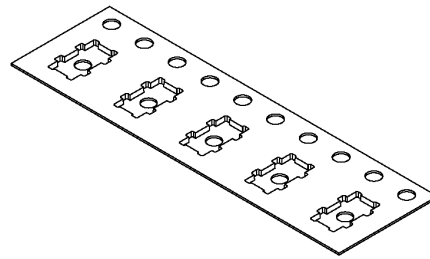
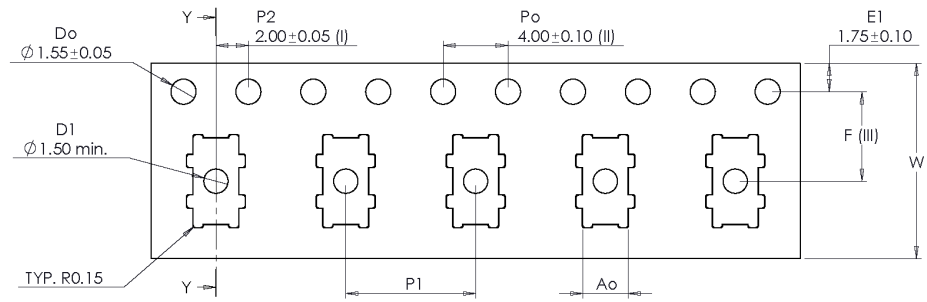

| | | |
|----|-------|----------|
| Ao | 2.80 | +/- 0.10 |
| Bo | 5.30 | +/- 0.10 |
| Ko | 0.55 | +/- 0.05 |
| F | 5.50 | +/- 0.05 |
| P1 | 8.00 | +/- 0.10 |
| W | 12.00 | +/- 0.30 |

Forming format : Press Form - 17
Estimated max. length : 278 meter/22B3 reel

- (I) Measured from centreline of sprocket hole to centreline of pocket.
- (II) Cumulative tolerance of 10 sprocket holes is ± 0.20 .
- (III) Measured from centreline of sprocket hole to centreline of pocket.
- (IV) Other material available.

ALL DIMENSIONS IN MILLIMETRES UNLESS OTHERWISE STATED.

(1) Pin 1 will be oriented in the top left quadrant of the tape enclosure (closest to the carrier tape sprocket holes).

REVISION HISTORY

Changes from Original (March 2013) to Revision A

Page

- Changed $R_{\theta JC-PCB}$ To: $R_{\theta JC}$ in the THERMAL INFORMATION table **3**

PACKAGING INFORMATION

| Orderable Device | Status (1) | Package Type | Package Drawing | Pins | Package Qty | Eco Plan (2) | Lead/Ball Finish | MSL Peak Temp (3) | Op Temp (°C) | Top-Side Markings (4) | Samples |
|------------------|---------------|--------------|--------------------|------|----------------|----------------------------|------------------|----------------------|--------------|--------------------------|---------|
| CSD87588N | ACTIVE | PTAB | MPA | 5 | 2500 | Green (RoHS & no Sb/Br) | CU NIPDAU | Level-1-260C-UNLIM | -55 to 150 | 87588N | Samples |

(1) The marketing status values are defined as follows:

ACTIVE: Product device recommended for new designs.

LIFEBUY: TI has announced that the device will be discontinued, and a lifetime-buy period is in effect.

NRND: Not recommended for new designs. Device is in production to support existing customers, but TI does not recommend using this part in a new design.

PREVIEW: Device has been announced but is not in production. Samples may or may not be available.

OBSELETE: TI has discontinued the production of the device.

(2) Eco Plan - The planned eco-friendly classification: Pb-Free (RoHS), Pb-Free (RoHS Exempt), or Green (RoHS & no Sb/Br) - please check <http://www.ti.com/productcontent> for the latest availability information and additional product content details.

TBD: The Pb-Free/Green conversion plan has not been defined.

Pb-Free (RoHS): TI's terms "Lead-Free" or "Pb-Free" mean semiconductor products that are compatible with the current RoHS requirements for all 6 substances, including the requirement that lead not exceed 0.1% by weight in homogeneous materials. Where designed to be soldered at high temperatures, TI Pb-Free products are suitable for use in specified lead-free processes.

Pb-Free (RoHS Exempt): This component has a RoHS exemption for either 1) lead-based flip-chip solder bumps used between the die and package, or 2) lead-based die adhesive used between the die and leadframe. The component is otherwise considered Pb-Free (RoHS compatible) as defined above.

Green (RoHS & no Sb/Br): TI defines "Green" to mean Pb-Free (RoHS compatible), and free of Bromine (Br) and Antimony (Sb) based flame retardants (Br or Sb do not exceed 0.1% by weight in homogeneous material)

(3) MSL, Peak Temp. -- The Moisture Sensitivity Level rating according to the JEDEC industry standard classifications, and peak solder temperature.

(4) Multiple Top-Side Markings will be inside parentheses. Only one Top-Side Marking contained in parentheses and separated by a "~" will appear on a device. If a line is indented then it is a continuation of the previous line and the two combined represent the entire Top-Side Marking for that device.

Important Information and Disclaimer:The information provided on this page represents TI's knowledge and belief as of the date that it is provided. TI bases its knowledge and belief on information provided by third parties, and makes no representation or warranty as to the accuracy of such information. Efforts are underway to better integrate information from third parties. TI has taken and continues to take reasonable steps to provide representative and accurate information but may not have conducted destructive testing or chemical analysis on incoming materials and chemicals. TI and TI suppliers consider certain information to be proprietary, and thus CAS numbers and other limited information may not be available for release.

In no event shall TI's liability arising out of such information exceed the total purchase price of the TI part(s) at issue in this document sold by TI to Customer on an annual basis.

TAPE AND REEL INFORMATION



QUADRANT ASSIGNMENTS FOR PIN 1 ORIENTATION IN TAPE



*All dimensions are nominal

| Device | Package Type | Package Drawing | Pins | SPQ | Reel Diameter (mm) | Reel Width W1 (mm) | A0 (mm) | B0 (mm) | K0 (mm) | P1 (mm) | W (mm) | Pin1 Quadrant |
|-----------|--------------|-----------------|------|------|--------------------|--------------------|---------|---------|---------|---------|--------|---------------|
| CSD87588N | PTAB | MPA | 5 | 2500 | 330.0 | 12.4 | 2.8 | 5.3 | 0.55 | 8.0 | 12.0 | Q1 |

TAPE AND REEL BOX DIMENSIONS



*All dimensions are nominal

| Device | Package Type | Package Drawing | Pins | SPQ | Length (mm) | Width (mm) | Height (mm) |
|-----------|--------------|-----------------|------|------|-------------|------------|-------------|
| CSD87588N | PTAB | MPA | 5 | 2500 | 367.0 | 367.0 | 35.0 |

IMPORTANT NOTICE

Texas Instruments Incorporated and its subsidiaries (TI) reserve the right to make corrections, enhancements, improvements and other changes to its semiconductor products and services per JESD46, latest issue, and to discontinue any product or service per JESD48, latest issue. Buyers should obtain the latest relevant information before placing orders and should verify that such information is current and complete. All semiconductor products (also referred to herein as "components") are sold subject to TI's terms and conditions of sale supplied at the time of order acknowledgment.

TI warrants performance of its components to the specifications applicable at the time of sale, in accordance with the warranty in TI's terms and conditions of sale of semiconductor products. Testing and other quality control techniques are used to the extent TI deems necessary to support this warranty. Except where mandated by applicable law, testing of all parameters of each component is not necessarily performed.

TI assumes no liability for applications assistance or the design of Buyers' products. Buyers are responsible for their products and applications using TI components. To minimize the risks associated with Buyers' products and applications, Buyers should provide adequate design and operating safeguards.

TI does not warrant or represent that any license, either express or implied, is granted under any patent right, copyright, mask work right, or other intellectual property right relating to any combination, machine, or process in which TI components or services are used. Information published by TI regarding third-party products or services does not constitute a license to use such products or services or a warranty or endorsement thereof. Use of such information may require a license from a third party under the patents or other intellectual property of the third party, or a license from TI under the patents or other intellectual property of TI.

Reproduction of significant portions of TI information in TI data books or data sheets is permissible only if reproduction is without alteration and is accompanied by all associated warranties, conditions, limitations, and notices. TI is not responsible or liable for such altered documentation. Information of third parties may be subject to additional restrictions.

Resale of TI components or services with statements different from or beyond the parameters stated by TI for that component or service voids all express and any implied warranties for the associated TI component or service and is an unfair and deceptive business practice. TI is not responsible or liable for any such statements.

Buyer acknowledges and agrees that it is solely responsible for compliance with all legal, regulatory and safety-related requirements concerning its products, and any use of TI components in its applications, notwithstanding any applications-related information or support that may be provided by TI. Buyer represents and agrees that it has all the necessary expertise to create and implement safeguards which anticipate dangerous consequences of failures, monitor failures and their consequences, lessen the likelihood of failures that might cause harm and take appropriate remedial actions. Buyer will fully indemnify TI and its representatives against any damages arising out of the use of any TI components in safety-critical applications.

In some cases, TI components may be promoted specifically to facilitate safety-related applications. With such components, TI's goal is to help enable customers to design and create their own end-product solutions that meet applicable functional safety standards and requirements. Nonetheless, such components are subject to these terms.

No TI components are authorized for use in FDA Class III (or similar life-critical medical equipment) unless authorized officers of the parties have executed a special agreement specifically governing such use.

Only those TI components which TI has specifically designated as military grade or "enhanced plastic" are designed and intended for use in military/aerospace applications or environments. Buyer acknowledges and agrees that any military or aerospace use of TI components which have **not** been so designated is solely at the Buyer's risk, and that Buyer is solely responsible for compliance with all legal and regulatory requirements in connection with such use.

TI has specifically designated certain components as meeting ISO/TS16949 requirements, mainly for automotive use. In any case of use of non-designated products, TI will not be responsible for any failure to meet ISO/TS16949.

Products

| | |
|------------------------------|--|
| Audio | www.ti.com/audio |
| Amplifiers | amplifier.ti.com |
| Data Converters | dataconverter.ti.com |
| DLP® Products | www.dlp.com |
| DSP | dsp.ti.com |
| Clocks and Timers | www.ti.com/clocks |
| Interface | interface.ti.com |
| Logic | logic.ti.com |
| Power Mgmt | power.ti.com |
| Microcontrollers | microcontroller.ti.com |
| RFID | www.ti-rfid.com |
| OMAP Applications Processors | www.ti.com/omap |
| Wireless Connectivity | www.ti.com/wirelessconnectivity |

Applications

| | |
|-------------------------------|--|
| Automotive and Transportation | www.ti.com/automotive |
| Communications and Telecom | www.ti.com/communications |
| Computers and Peripherals | www.ti.com/computers |
| Consumer Electronics | www.ti.com/consumer-apps |
| Energy and Lighting | www.ti.com/energy |
| Industrial | www.ti.com/industrial |
| Medical | www.ti.com/medical |
| Security | www.ti.com/security |
| Space, Avionics and Defense | www.ti.com/space-avionics-defense |
| Video and Imaging | www.ti.com/video |

TI E2E Community

e2e.ti.com