

PART NUMBER	ITEM ① BODY	ITEM ② CONTACT	ITEM ③ INSULATOR	ITEM ④ CRIMP SLEEVE	ITEM ⑤ COUPLING NUT
27-9213	BRASS NICKEL PLATED	BRASS GOLD PLATED	DELTRIN WHITE	BRASS NICKEL PLATED	ZINC NICKEL PLATED

受控 CONTROLLED DOCUMENT

编号 P/N	27-9230	版本 Rev	0B	日期 Rel'd Date	Mar 24,08
-----------	---------	-----------	----	------------------	-----------

DRAWING NO. 27-9213					
REVISIONS					
RELEASE FOR QUATION					
A	11-09-07	Z	W	T	
REVISE INSULATOR PP TO DELTRIN					
B	01-25-08	Z	W	T	Thomas Chow

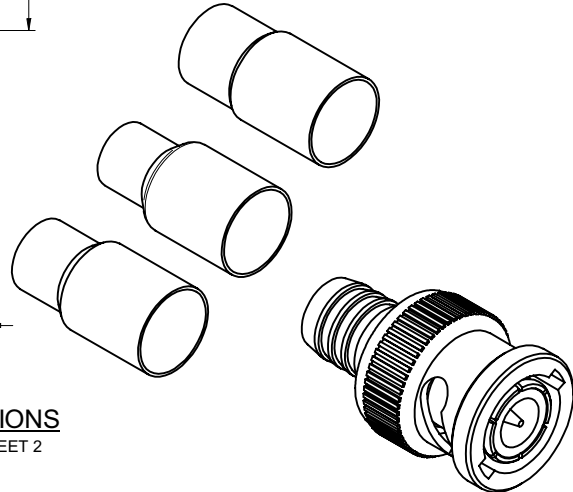
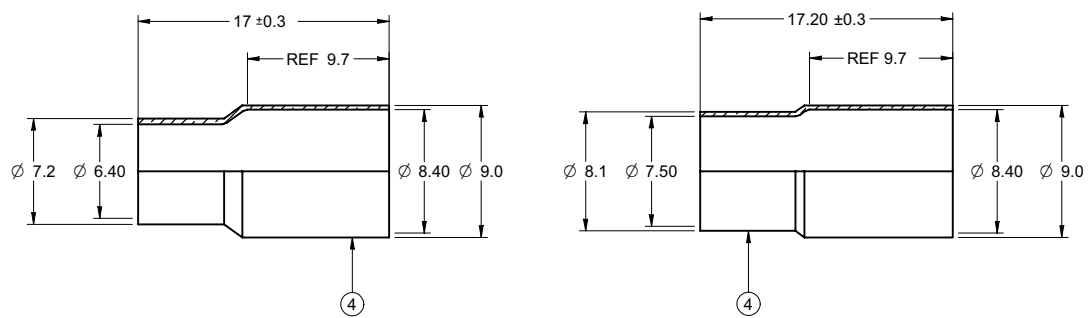
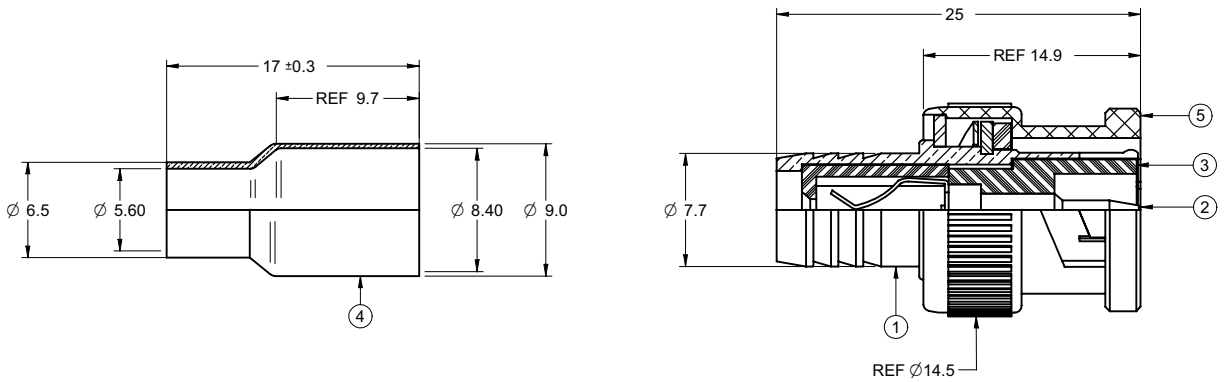

CABLE STRIP DIMENSIONS
ASSEMBLY INSTRUCTIONS ON SHEET 2

NOTES:

- ELECTRICAL SPECIFICATIONS**
 IMPEDANCE: 50 OHMS NOMINAL
 FREQUENCY RANGE: 0-4 GHz
 WORKING VOLTAGE: 500 Vrms MAX AT SEA LEVEL
 DIELECTRIC WITHSTANDING VOLTAGE: 1500 vrms AT SEA LEVEL
 CORONA LEVEL: 375 VOLTS MINIMUM AT 70,000 FEET
 CONTACT RESISTANCE: OUTER - NICKEL PLATED INITIAL 2.5 MILLIOHMS MAXIMUM
 AFTER ENVIRONMENTAL 3.5 MILLIOHMS MAXIMUM
 CENTER - INITIAL 3 MILLIOHMS MAXIMUM
 AFTER ENVIRONMENTAL 4 MILLIOHMS MAXIMUM
 BRAID TO BODY - 2.5 MILLIOHMS MAXIMUM (NICKEL PLATED),
 AFTER ENVIRONMENTAL NOT APPLICABLE
 INSULATION RESISTANCE: 5000 MEGOHMS MINIMUM
- MECHANICAL SPECIFICATIONS**
 DURABILITY: 500 CYCLES MIN
 CABLE ACCEPTABILITY: RG6, RG58, RG59, RG59 PLENUM
 CABLE RETENTION: 20 lbs MIN
 THE MATERIAL OF CRIMP SLEEVE SHALL HAVE A MAXIMUM HARDNESS OF 85 VICKERS.
- ENVIRONMENTAL SPECIFICATIONS**
 RECOMMENDED TEMPERATURE RANGE: -55 °C TO +85 °C
 MOISTURE RESISTANCE: MIL-STD-202
- PRODUCT SHOULD BE RoHS COMPLIANCE.
- PACKAGING REQUIREMENT FOLLOWS ENGINEER DOCUMENT P/N 836-40200001XX

THIS DRAWING TO BE INTERPRETED PER ANSI Y 14.5M - 1994

COMPANY CONFIDENTIAL

TOLERANCE UNLESS OTHERWISE SPECIFIED		DRAWN BY GARY.ZHG	DATE 01-25-08
DECIMALS	mm	CHECKED BY LINDA.WU	DATE 01-25-08
X	± 0.5	APPROVED BY THOMAS	DATE 01-31-08
X.X	± 0.2		
X.XX	± 0.1		
ANGLES	± 0.5°	U/M	mm

EMERSON
Network Power

Connectivity Solutions

TITLE: 50 OHM BNC(M) CRIMP-ON, 2 PIECE, (3) FERRULES FOR RG-6, 58, 59 & 59TFE

THIS DRAWING WAS PRODUCED BY COMPUTER, DO NOT SCALE DRAWING OR UPDATE MANUALLY.		SHEET 1 OF 2	DRAWING NO. 27-9213	SIZE C
---	--	-----------------	------------------------	-----------

PART NUMBER	CABLE	CRIMP BRAID HEX	CRIMP (STRAIN RELIEF)	RECOMMENDED CRIMP TOOL
27-9213	RG6, RG58, RG59 RG59 TFE	8.13	5.41/6.48	24-8859P

受控 CONTROLLED DOCUMENT

编号 P/N	27-9230	版本 Rev	0B	日期 Rel'd Date	Mar 24, 08
-----------	---------	-----------	----	------------------	------------

DRAWING NO. 27-9213	
REVISIONS	
RELEASE FOR QUOTATION	
A	11-09-07 Z W T
VERSION UPDATE	
B	01-25-08 Z W T

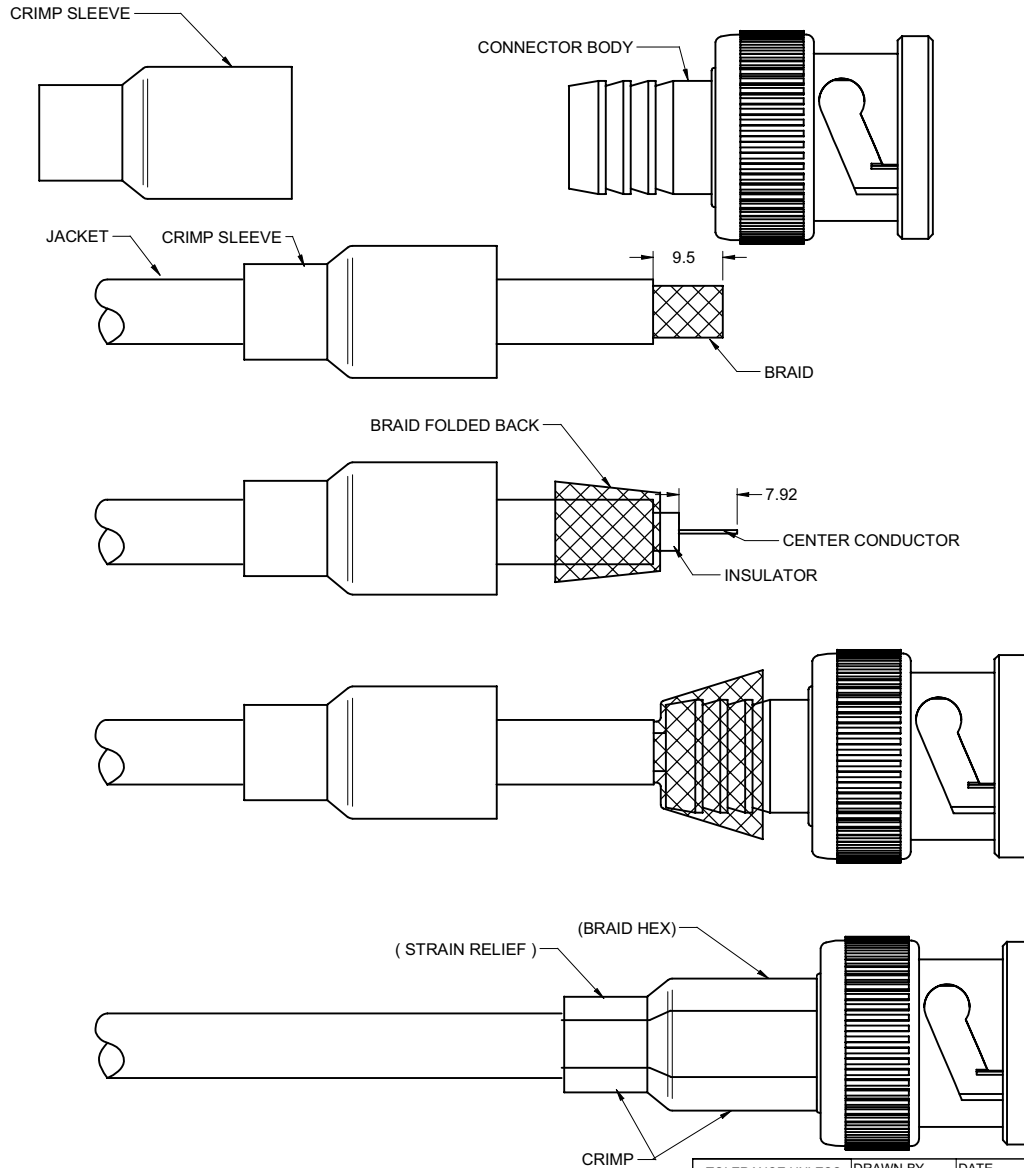

ASSEMBLY INSTRUCTIONS

1. RUN CRIMP SLEEVE DOWN CABLE.
2. TRIM CABLES AS SHOWN, TAKING CARE NOT TO NICK OUTER BRAID.
3. INSERT CENTER CONDUCTOR INTO THE GUIDE HOLE IN THE REAR OF THE CONNECTOR. THEN SCREW THE CONNECTOR ON THE CABLE IN A CLOCKWISE DIRECTION.
4. PUSH CRIMP SLEEVE INTO PLACE, SANDWICHING THE BRAID BETWEEN THE CONNECTOR AND SLEEVE.
5. CRIMP THE SLEEVE INTO PLACE WITH THE PROPER CRIMP TOOL.

THIS DRAWING TO BE INTERPRETED PER ANSI Y 14.5M - 1994

COMPANY CONFIDENTIAL

TOLERANCE UNLESS OTHERWISE SPECIFIED		DRAWN BY GARY.ZHG	DATE 01-25-08
DECIMALS	mm	CHECKED BY LINDA.WU	DATE 01-25-08
X	± 0.5	APPROVED BY THOMAS	DATE 01-31-08
X.X	± 0.2		
X.XX	± 0.1		
ANGLES	± 0.5°	U/M	mm

THIS DRAWING WAS PRODUCED BY COMPUTER, DO NOT SCALE DRAWING OR UPDATE MANUALLY.

EMERSON Network Power		Connectivity Solutions	
TITLE 50 OHM BNC(M) CRIMP-ON, 2 PIECE, (3) FERRULES FOR RG-6, 58, 59 & 59TFE			
SHEET 1 OF 2	DRAWING NO. 27-9213	SIZE C	