

# Integrated Digital Light Sensor with Interrupt

## ISL29023

The ISL29023 is an integrated ambient and infrared light to digital converter with I<sup>2</sup>C (SMBus Compatible) Interface. Its advanced self-calibrated photodiode array emulates human eye response with excellent IR rejection. The on-chip ADC is capable of rejecting 50Hz and 60Hz flicker caused by artificial light sources. The lux range select feature allows users to program the lux range for optimized counts/lux.

For ambient light sensing, an internal 16-bit ADC has been designed based upon the charge-balancing technique. The ADC conversion time is nominally 90ms and is user adjustable from 11µs to 90ms, depending on oscillator frequency and ADC resolution. In normal operation, typical current consumption is 70µA. In order to further minimize power consumption, two power-down modes have been provided. If polling is chosen over continuous measurement of light, the auto-power-down function shuts down the whole chip after each ADC conversion for the measurement. The other power-down mode is controlled by software via the I<sup>2</sup>C interface. The power consumption can be reduced to less than 0.3µA when powered down.

The ISL29023 supports a software and hardware interrupt that remains asserted until the host clears it through I<sup>2</sup>C interface. Function of ADC conversion continues without stopping after interrupt is asserted.

Designed to operate on supplies from 2.25V to 3.63V with an I<sup>2</sup>C supply from 1.7V to 3.63V, the ISL29023 is specified for operation over the -40 °C to +85 °C ambient temperature range.

## Features

- Resolution . . . . .16-bits ADC
- Integrated noise reduction . . . . . 50/60Hz
- Light sensor close to human eye response
- Excellent light sensor IR and UV rejection
- Range selection via I<sup>2</sup>C
  - Range1 = 0.015 to 1,000 Lux
  - Range2 = 0.06 to 4,000 Lux
  - Range3 = 0.24 to 16,000 Lux
  - Range4 = 0.96 to 64,000 Lux
- Shutdown modes . . . . .Software & Automatic
- Supply current (Max) . . . . . 85µA
- Shutdown current (Max) . . . . .0.3µA
- Control interface . . . . . I<sup>2</sup>C and SMB Compatible
- I<sup>2</sup>C power supply . . . . . 1.7V to 3.63V
- Sensor power supply . . . . . 2.25V to 3.63V
- Operating temperature range. . . . . -40 °C to +85 °C
- Small form factor package . . . . . 6 Ld 2.0x2.1x0.7 ODFN

## Applications

- Mobile devices: smart phone, PDA, GPS
- Computing devices: Notebook PC, Webpad
- Consumer devices: LCD-TV, digital picture frame, digital camera
- Industrial and medical light sensing

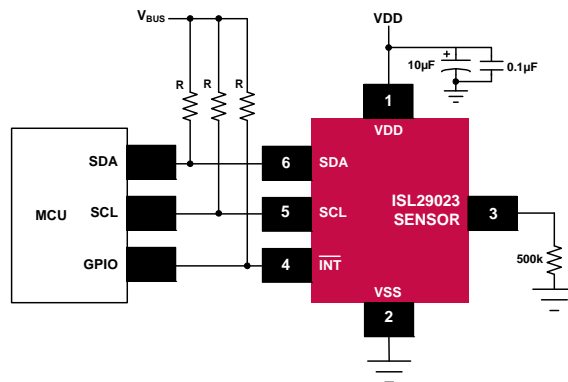

FIGURE 1. ISL29023 TYPICAL APPLICATION DIAGRAM

For additional products, see [www.intersil.com/product\\_tree](http://www.intersil.com/product_tree)

---

Intersil products are manufactured, assembled and tested utilizing ISO9000 quality systems as noted in the quality certifications found at [www.intersil.com/design/quality](http://www.intersil.com/design/quality)

---

*Intersil products are sold by description only. Intersil Corporation reserves the right to make changes in circuit design, software and/or specifications at any time without notice. Accordingly, the reader is cautioned to verify that data sheets are current before placing orders. Information furnished by Intersil is believed to be accurate and reliable. However, no responsibility is assumed by Intersil or its subsidiaries for its use; nor for any infringements of patents or other rights of third parties which may result from its use. No license is granted by implication or otherwise under any patent or patent rights of Intersil or its subsidiaries.*

---

For information regarding Intersil Corporation and its products, see [www.intersil.com](http://www.intersil.com)