

USB 2.0 High-Speed (480 Mbps) and Audio Switches with Negative Signal Capability and 1.8-V Logic Compatibility and Power-Down Mode

 Check for Samples: [TS3USBA225](#)

FEATURES

- 2.7-V to 4.3-V Operating Power Supply (VCC)
- MHL/High-Speed USB (480Mbps) Switch:
 - V/I/O Accepts Signals up to 4.3 V (Independent of VCC)
 - 6.5 Ω RDSON Typical
 - 3 pF CON Typical
 - 1.9 GHz Bandwidth (–3 dB)
- Audio Switch:
 - 2.5 Ω RDSON Typical
 - Negative Rail Capability –1.8 V to VCC
 - Low THD: < 0.05%
 - Internal Shunt Resistors for Click-and-Pop Reduction
- 1.8-V Compatible Control Input (SEL1 and SEL2) Threshold
- Minimized Current Consumption (~5 μ A) in Power-Down Mode
- Power-Off Protection: All I/O Pins are High-Z when $V_{CC} = 0$ V
- 12-Pin QFN Package (2 x 1.7 mm, 0.4-mm pitch)

- ESD Performance Tested per JESD 22
 - 2000-V Human-Body Model (A114-B, Class II)
 - 1000-V Charged-Device Model (C101)

APPLICATIONS

- Cell phones and Smartphones
- Tablet PCs
- Portable Instrumentation
- Digital Still Cameras
- Portable Navigation Devices (GPS)
- USB 2.0, MIPI (CSI/DSI), LVDS switching

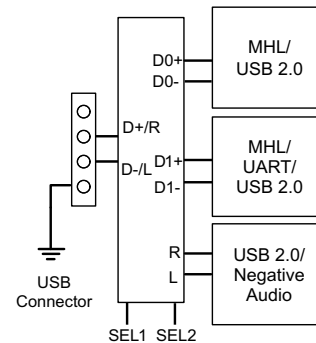

DESCRIPTION

The TS3USBA225 is a double-pole, triple throw (DP3T) multiplexer that supports USB 2.0 High-Speed (480 Mbps) signals in all 3 differential channels. The first two high-speed channels also support Mobile High Definition Link (MHL) signaling with video data rates up to 720p, 60fps and 1080i, 30fps. One of the differential channels can also be used as an audio switch that is designed to allow audio signals to swing negatively. This configuration allows the system designer to use a common connector for audio and USB data.

The TS3USBA225 has a VCC range of 2.7 V to 4.3 V with the capability to pass true-ground audio signals down to –1.8 V. The device also supports a power-down mode that can be enabled when both SEL controls are low to minimize current consumption when no signal is transmitting. The TS3USBA225 also features internal shunt resistors on the audio path to reduce clicks and pops that may be heard when the audio switches are selected.

ORDERING INFORMATION

T_A	PACKAGE ^{(1) (2)}	ORDERABLE PART NUMBER	TOP-SIDE MARKING
–40°C to 85°C	QFN 0.4-mm pitch – RUT (Pb-Free) Tape and reel	TS3USBA225RUTR	LQR

(1) Package drawings, thermal data, and symbolization are available at www.ti.com/packaging.

(2) For the most current package and ordering information, see the Package Option Addendum at the end of this document, or see the TI website at www.ti.com.



Please be aware that an important notice concerning availability, standard warranty, and use in critical applications of Texas Instruments semiconductor products and disclaimers thereto appears at the end of this data sheet.



These devices have limited built-in ESD protection. The leads should be shorted together or the device placed in conductive foam during storage or handling to prevent electrostatic damage to the MOS gates.

SWITCH BLOCK DIAGRAM

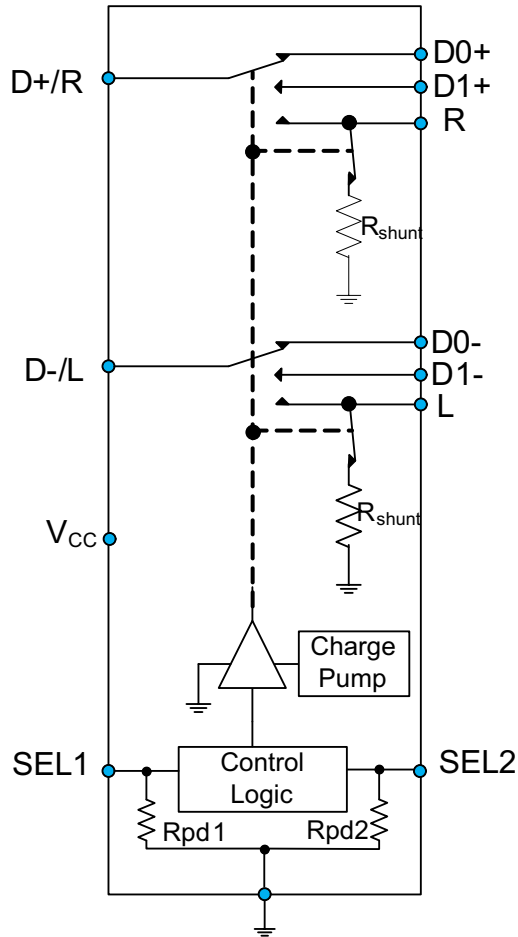

TYPICAL APPLICATION BLOCK DIAGRAM

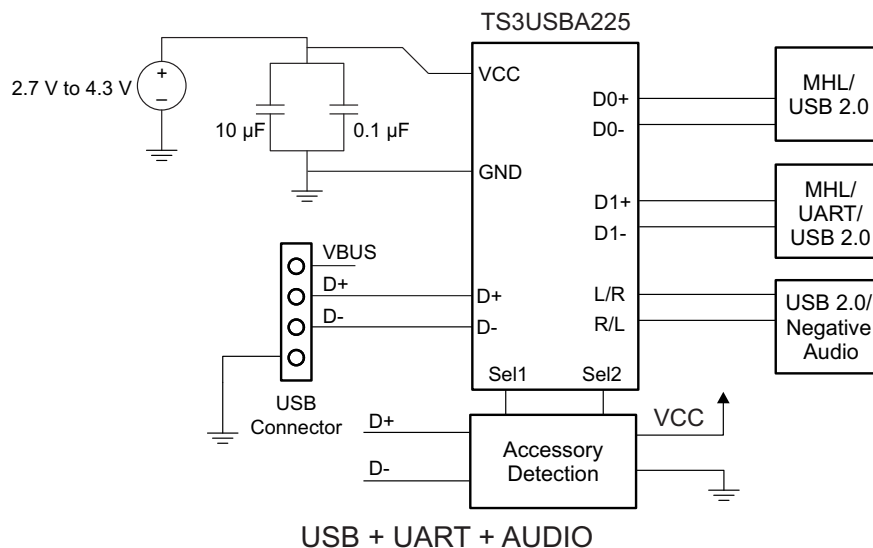

PIN CONFIGURATION

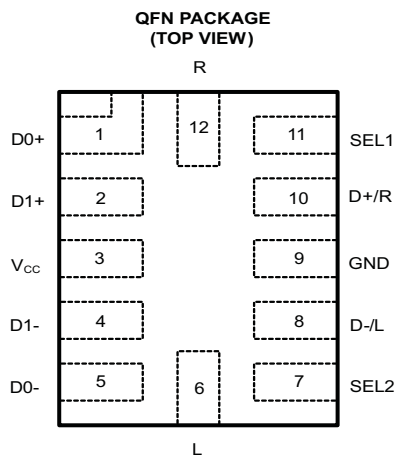

12-Pin QFN Package (2x1.7 mm, 0.4mm pitch)

PIN DESCRIPTION TABLE

PIN			DESCRIPTION
NUMBER	NAME	TYPE	
1	D0+	I/O	MHL/USB/UART Data 1 (Differential +)
2	D1+	I/O	MHL/USB/UART Data 2 (Differential +)
3	VCC	Power	Power supply
4	D1-	I/O	MHL/USB/UART Data 2 (Differential -)
5	D0-	I/O	MHL/USB/UART Data 1 (Differential -)
6	L	I/O	USB-/Left Channel Audio
7	SEL2	Input	Control Input Select Line 2. The default state for SEL2 is LOW.
8	D-/L	I/O	MHL/USB/UART/Audio Common Connector
9	GND	Ground	Ground
10	D+/R	I/O	MHL/USB/UART/Audio Common Connector
11	SEL1	Input	Control Input Select Line 1. The default state for SEL1 is LOW.
12	R	I/O	USB+/Right Channel Audio

FUNCTION TABLE

SEL1	SEL2	V _{CC}	L,R	D0+, D0-	D1+, D1-	Mode
X	X	L	OFF	OFF	OFF	Hi-Z Mode
L	L	H	OFF	OFF	OFF	Power-Down Mode
L	H	H	OFF ⁽¹⁾	ON	OFF	MHL/USB Mode 1
H	L	H	ON	OFF	OFF	USB/Audio Mode
H	H	H	OFF ⁽¹⁾	OFF	ON	MHL/USB Mode 2

(1) 100Ω shunt resistors are enabled in this state.

SUMMARY OF TYPICAL CHARACTERISTICS

	USB PATH	USB/AUDIO PATH
Number of switches	4	2
ON-state resistance (r _{on})	6.5 Ω	2.5 Ω
ON-state resistance match (Δr _{on})	0.1 Ω	0.1 Ω
ON-state resistance flatness (r _{on(flat)})	2 Ω	1.5 Ω
ON-state capacitance (C _{I/O,on})	3 pF	3.5 pF
Bandwidth (BW)	1.9 GHz	1.2 GHz
Total harmonic distortion (THD)	N/A	0.05%

ABSOLUTE MAXIMUM RATINGS⁽¹⁾⁽²⁾

over operating free-air temperature range (unless otherwise noted)

	MIN	MAX	UNIT
V _{CC} Supply voltage range ⁽³⁾	-0.3	4.6	V
V _{D0+} , V _{D0-} , V _{D1+} , V _{D1-} High speed differential signal voltage range ⁽³⁾	-0.3	4.6	V
V _R , V _L Audio signal voltage range	-1.9	V _{CC}	V
I _K Analog port diode current V _{I/O+} , V _{I/O-} < 0	-50		mA
V _I Digital input voltage range (SEL1, SEL2)	-0.3	4.6	V
I _{IK} Digital logic input clamp current ⁽³⁾ V _I < 0	-50		
I _{CC} Continuous current through VCC		100	mA
I _{GND} Continuous current through GND	-100		mA
T _{stg} Storage temperature range	-65	150	°C

- (1) Stresses beyond those listed under "absolute maximum ratings" may cause permanent damage to the device. These are stress ratings only, and functional operation of the device at these or any other conditions beyond those indicated under "recommended operating conditions" is not implied. Exposure to absolute-maximum-rated conditions for extended periods may affect device reliability.
- (2) The algebraic convention, whereby the most negative value is a minimum and the most positive value is a maximum.
- (3) All voltages are with respect to ground, unless otherwise specified.

RECOMMENDED OPERATING CONDITIONS

	MIN	MAX	UNIT
V _{CC} Supply voltage range	2.7	4.3	V
V _{D0+} , V _{D0-} , V _{D1+} , V _{D1-} High speed differential signal voltage range	0	4.3	V
V _R , V _L Audio signal voltage range	-1.8	V _{CC}	V
I _K Analog port diode current V _{I/O+} , V _{I/O-} < 0	-50		mA
V _I Digital input voltage range (SEL1, SEL2)	0	4.3	V
T _A Operating free-air temperature	-40	85	°C

ELECTRICAL CHARACTERISTICS

$T_A = -40^{\circ}\text{C}$ to 85°C , typical values are at $V_{CC} = 3.3\text{ V}$, $T_A = 25^{\circ}\text{C}$ (unless otherwise noted)

PARAMETER		TEST CONDITIONS		MIN	TYP	MAX	UNIT
MHL/USB SWITCH							
r_{on}	ON-state resistance	$V_{CC} = 3.0\text{ V}$	$V_{I/O+,I/O-} = 0.4\text{ V}$, $I_{ON} = 15\text{ mA}$	6.5	7.5		Ω
Δr_{on}	ON-state resistance match between channels	$V_{CC} = 3.0\text{ V}$	$V_{I/O+,I/O-} = 1.7\text{ V}$, $I_{ON} = 15\text{ mA}$	0.1			Ω
$r_{on (flat)}$	ON-state resistance flatness	$V_{CC} = 3.0\text{ V}$	$V_{I/O+,I/O-} = 0$ to 1.7 V , $I_{ON} = 15\text{ mA}$	0.5			Ω
I_{OZ}	OFF leakage current	$V_{CC} = 3.6\text{ V}$	Switch OFF, $V_{I/O+,I/O-} = 0$ to 3.6 V , 1789553 $V_{D+/R, D-/L} = 0\text{ V}$			1	μA
USB/AUDIO SWITCH							
r_{on}	ON-state resistance	$V_{CC} = 3.0\text{ V}$	SEL1=High, SEL2=Low, $V_{L/R} = -2\text{V}, 0\text{V}, 0.7\text{V}$, $I_{ON} = -26\text{ mA}$	2.5	3.5		Ω
Δr_{on}	ON-state resistance match between channels	$V_{CC} = 3.0\text{ V}$	SEL1=High, SEL2=Low, $V_{L/R} = 0.7\text{V}$, $I_{ON} = -26\text{ mA}$	0.1			Ω
$r_{on (flat)}$	ON-state resistance flatness	$V_{CC} = 3.0\text{ V}$	SEL1=High, SEL2=Low, $V_{L/R} = -2\text{V}, 0\text{V}, 0.7\text{V}$, $I_{ON} = -26\text{ mA}$	0.1			Ω
r_{SHUNT}	Shunt resistance	$V_{CC} = 2.7\text{ V}$ to 4.3 V	Switch OFF, $V_{L/R} = 0.7\text{V}$, $I_{SHUNT} = 10\text{ mA}$	100	200		Ω
DIGITAL CONTROL INPUTS (SEL1, SEL2)							
V_{IH}	Input logic high	$V_{CC} = 2.7\text{ V}$ to 4.3 V		1.3			V
V_{IL}	Input logic low	$V_{CC} = 2.7\text{ V}$ to 4.3 V			0.4		V
I_{IN}	Input leakage current	$V_{CC} = 2.7\text{ V}$ to 4.3 V	$V_{IN} = 4.3\text{V}$			± 3	μA
			$V_{IN} = 0\text{V}$			± 0.1	
r_{PD1} , r_{PD2}	Internal pulldown resistance	$V_{CC} = 2.7\text{ V}$ to 4.3 V			3		M Ω

DYNAMIC CHARACTERISTICS

T_A = -40°C to 85°C, typical values are at V_{CC} = 3.3 V, T_A = 25°C (unless otherwise noted)

PARAMETER		TEST CONDITIONS		MIN	TYP	MAX	UNIT
MHL/USB SWITCH							
t _{pd}	Propagation Delay	V _{CC} = 2.7V or 3.3V		0.25			ns
t _{ON}	Turn-on time	RL = 50Ω, CL = 35pF	V _{CC} = 2.7V	60			ns
t _{OFF}	Turn-off time	RL = 50Ω, CL = 35pF	V _{CC} = 2.7V	20			ns
t _{SK(O)}	Channel-to-channel skew	V _{CC} = 2.7V or 3.3V		15			ps
t _{SK(P)}	Skew of opposite transitions of same output	V _{CC} = 2.7V or 3.3V		15			ps
C _{I/O+(OFF)} C _{I/O-(OFF)}	OFF capacitance	V _{CC} = 2.7V or 3.3V, V _{D0+/D0-} = 0 or 3.3V	Switch OFF	1			pF
C _{I/O+(ON)} C _{I/O-(ON)}	ON capacitance	V _{CC} = 2.7V or 3.3V, V _{D0+/D0-} = 0 or 3.3V	Switch ON	3			pF
C _I	Digital input capacitance	V _{CC} = 2.7V or 3.3V, V _I = 0 or 3.3V 2.5					pF
BW	Bandwidth	V _{CC} = 2.7V or 3.3V, R _L = 50Ω	Switch ON	1.9			GHz
O _{ISO}	OFF Isolation	V _{CC} = 2.7V or 3.3V, R _L = 50Ω, f = 240 MHz	Switch OFF	-35			dB
X _{TALK}	Crosstalk	V _{CC} = 2.5V or 3.3V, R _L = 50Ω, f = 240 MHz	Switch ON	-45			dB
USB/AUDIO SWITCH							
t _{ON}	Turn-on time	R _L = 50Ω, C _L = 35pF	V _{CC} = 2.7V	40			μs
t _{OFF}	Turn-off time	R _L = 50Ω, C _L = 35pF	V _{CC} = 2.7V	15			ns
C _{L(OFF)} , C _{R(OFF)}	L, R OFF capacitance	V _{CC} = 2.7V to 4.3V, f = 20 kHz	Switch OFF	1.0			pF
C _{L(ON)} , C _{R(ON)}	L, R ON capacitance	V _{CC} = 2.7V to 4.3V, f = 20 kHz	Switch ON	3.5			pF
O _{ISO}	OFF Isolation	V _{CC} = 3.3V, R _L = 50Ω, f = 20 kHz	Switch OFF	-85			dB
X _{TALK}	Crosstalk	V _{CC} = 3.3V, R _L = 50Ω, f = 20 kHz	Switch ON	-95			dB
THD	Total harmonic distortion	V _{CC} = 3.3V, SEL1=High, SEL2=Low, f = 20Hz to 20kHz, R _L = 600Ω, V _{IN} = 2Vpp	Switch ON	0.05%			
SUPPLY							
V _{CC}	Power supply voltage			2.7	4.3		V
I _{CC}	Positive supply current	V _{CC} = 2.7V, 3.6V, V _{IN} =V _{CC} or GND, V _{I/O} =0V, Switch ON or OFF		25	50		μA
I _{CC, PD}	Positive supply current (Power-Down Mode)	V _{CC} = 2.7V, 3.6V, V _{IN} =V _{CC} or GND, V _{I/O} =0V, SEL1 and SEL2 = Low		3	5		μA
I _{OFF}	Power off leakage current	V _{CC} = 0V, V _{D+/R} , D-/L, D0+, D0-, D1+, D1-, L, R = 0 to 4.3V		±0.1			μA

TYPICAL CHARACTERISTICS

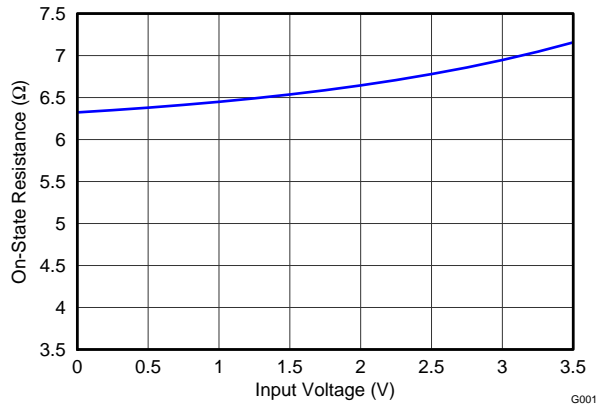

Figure 1. ON Resistance vs V_I for MHL/USB Switch

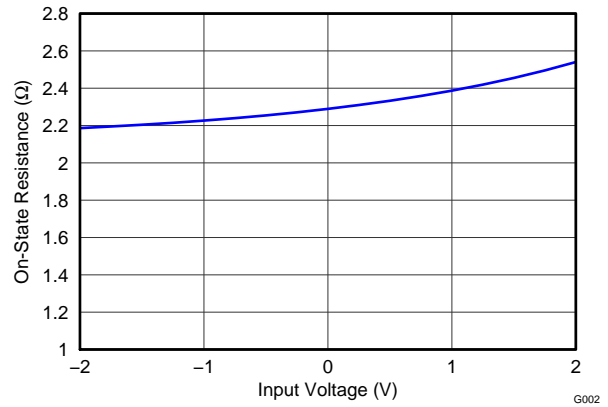

Figure 2. ON Resistance vs V_I for USB/Audio Switch

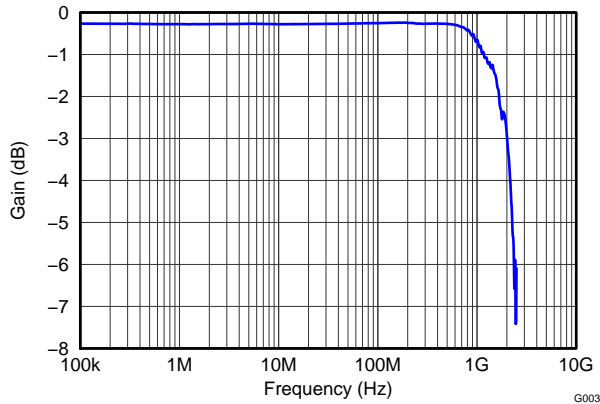

Figure 3. Gain vs Frequency for MHL/USB Switch

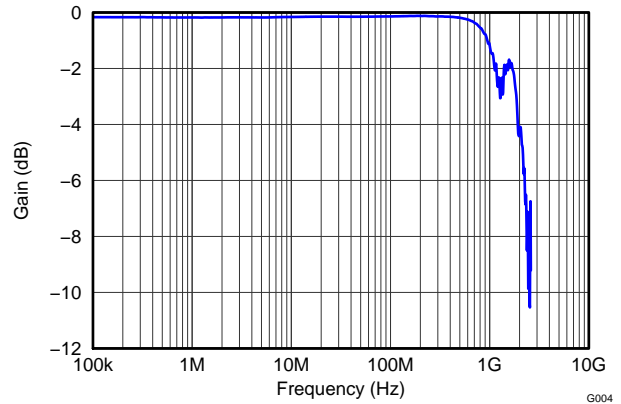

Figure 4. Gain vs Frequency for USB/Audio Switch

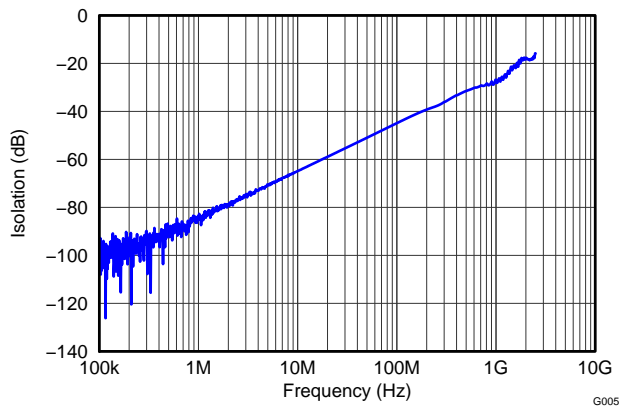

Figure 5. Off Isolation vs Frequency for MHL/USB Switch

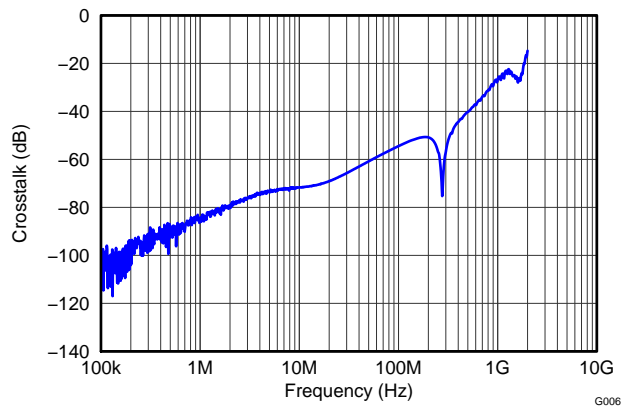

Figure 6. Cross Talk vs Frequency for MHL/USB Switch

TYPICAL CHARACTERISTICS (continued)

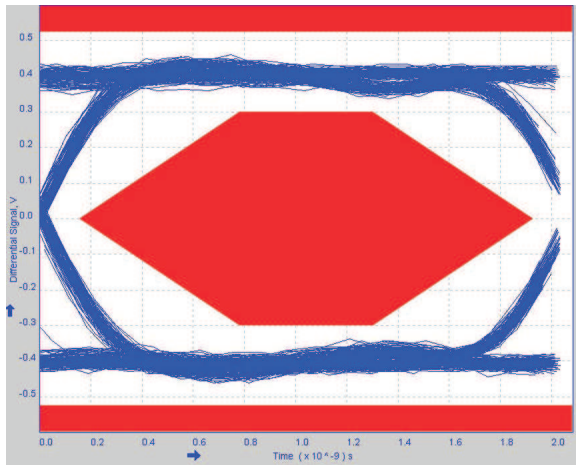

Figure 7. Eye Pattern: 480-Mbps USB 2.0 Eye Pattern (No Switch)

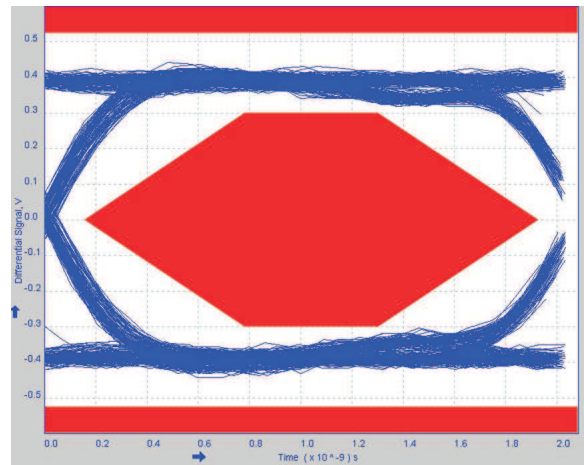

Figure 8. Eye Pattern: 480-Mbps USB 2.0 Eye Pattern for USB Switch

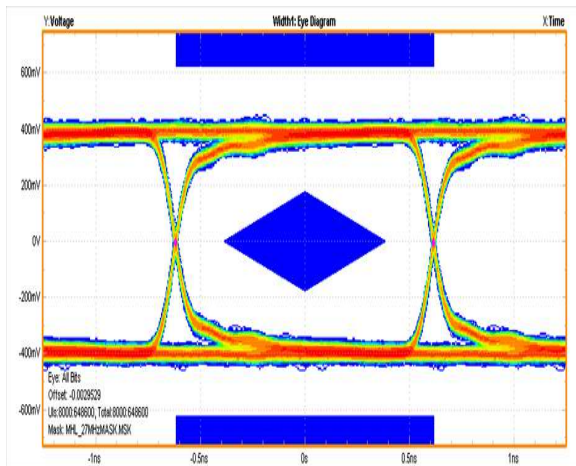

Figure 9. MHL Eye Pattern: 480p 60fps (No Switch)

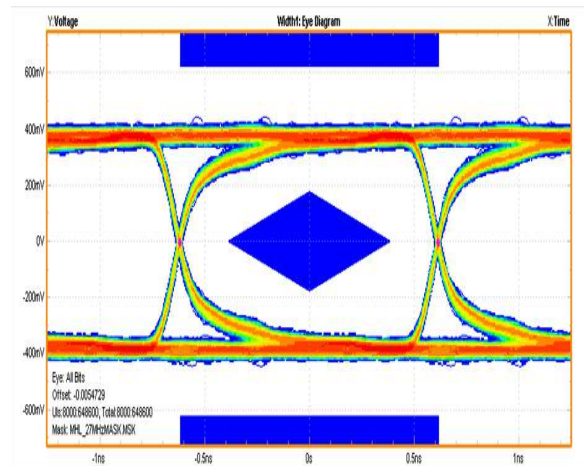

Figure 10. MHL Eye Pattern: 480p 60fps (With Switch)

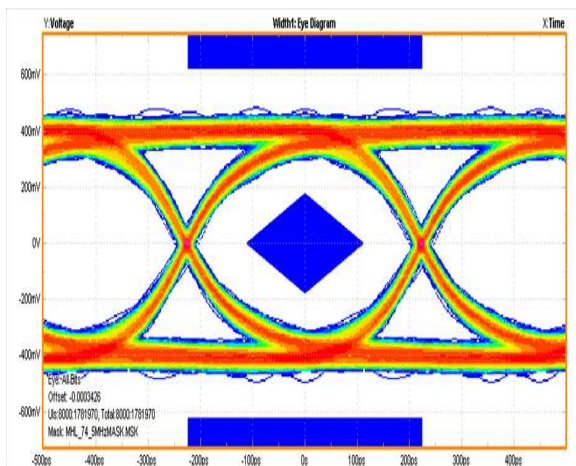

Figure 11. MHL Eye Pattern: 720p 60fps, 1080i 30fps (No Switch)

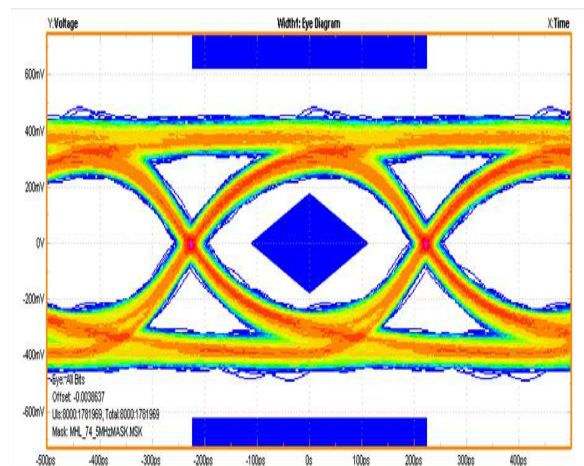

Figure 12. MHL Eye Pattern: 720p 60fps, 1080i 30fps (With Switch)

REVISION HISTORY

Changes from Original (October 2011) to Revision A Page

• Added MHL specification to datasheet.	1
• Updated Application Block Diagrams.	1
• Updated Switch Block Diagram	2
• Updated Typical Application Block Diagram	2
• Added MHL Eye Pattern graphics.	8

Changes from Revision A (April 2012) to Revision B Page

• Updated Application Block Diagrams.	1
• Updated MIN value in the ABSOLUTE MAXIMUM RATINGS table for V_R , V_L	4
• Updated MIN value in the RECOMMENDED OPERATING CONDITIONS table for V_R , V_L	4

PACKAGING INFORMATION

Orderable Device	Status (1)	Package Type	Package Drawing	Pins	Package Qty	Eco Plan (2)	Lead/Ball Finish (6)	MSL Peak Temp (3)	Op Temp (°C)	Device Marking (4/5)	Samples
TS3USBA225RUTR	ACTIVE	UQFN	RUT	12	3000	Green (RoHS & no Sb/Br)	CU NIPDAU CU NIPDAUAG	Level-1-260C-UNLIM	-40 to 85	(LQ7 ~ LQR)	Samples

(1) The marketing status values are defined as follows:

ACTIVE: Product device recommended for new designs.

LIFEBUY: TI has announced that the device will be discontinued, and a lifetime-buy period is in effect.

NRND: Not recommended for new designs. Device is in production to support existing customers, but TI does not recommend using this part in a new design.

PREVIEW: Device has been announced but is not in production. Samples may or may not be available.

OBSELETE: TI has discontinued the production of the device.

(2) Eco Plan - The planned eco-friendly classification: Pb-Free (RoHS), Pb-Free (RoHS Exempt), or Green (RoHS & no Sb/Br) - please check <http://www.ti.com/productcontent> for the latest availability information and additional product content details.

TBD: The Pb-Free/Green conversion plan has not been defined.

Pb-Free (RoHS): TI's terms "Lead-Free" or "Pb-Free" mean semiconductor products that are compatible with the current RoHS requirements for all 6 substances, including the requirement that lead not exceed 0.1% by weight in homogeneous materials. Where designed to be soldered at high temperatures, TI Pb-Free products are suitable for use in specified lead-free processes.

Pb-Free (RoHS Exempt): This component has a RoHS exemption for either 1) lead-based flip-chip solder bumps used between the die and package, or 2) lead-based die adhesive used between the die and leadframe. The component is otherwise considered Pb-Free (RoHS compatible) as defined above.

Green (RoHS & no Sb/Br): TI defines "Green" to mean Pb-Free (RoHS compatible), and free of Bromine (Br) and Antimony (Sb) based flame retardants (Br or Sb do not exceed 0.1% by weight in homogeneous material)

(3) MSL, Peak Temp. - The Moisture Sensitivity Level rating according to the JEDEC industry standard classifications, and peak solder temperature.

(4) There may be additional marking, which relates to the logo, the lot trace code information, or the environmental category on the device.

(5) Multiple Device Markings will be inside parentheses. Only one Device Marking contained in parentheses and separated by a "~" will appear on a device. If a line is indented then it is a continuation of the previous line and the two combined represent the entire Device Marking for that device.

(6) Lead/Ball Finish - Orderable Devices may have multiple material finish options. Finish options are separated by a vertical ruled line. Lead/Ball Finish values may wrap to two lines if the finish value exceeds the maximum column width.

Important Information and Disclaimer:The information provided on this page represents TI's knowledge and belief as of the date that it is provided. TI bases its knowledge and belief on information provided by third parties, and makes no representation or warranty as to the accuracy of such information. Efforts are underway to better integrate information from third parties. TI has taken and continues to take reasonable steps to provide representative and accurate information but may not have conducted destructive testing or chemical analysis on incoming materials and chemicals. TI and TI suppliers consider certain information to be proprietary, and thus CAS numbers and other limited information may not be available for release.

In no event shall TI's liability arising out of such information exceed the total purchase price of the TI part(s) at issue in this document sold by TI to Customer on an annual basis.

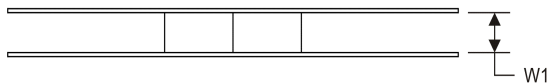
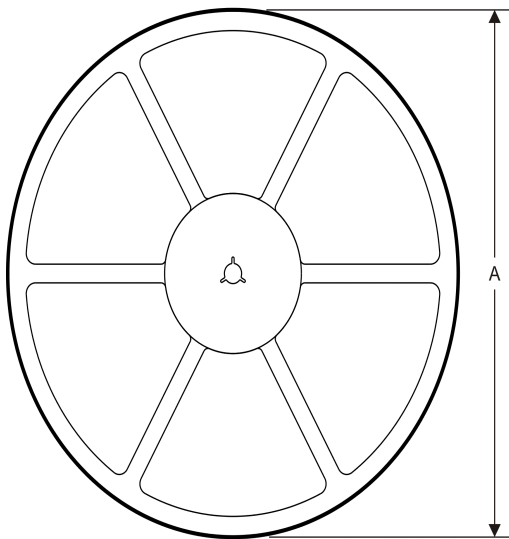
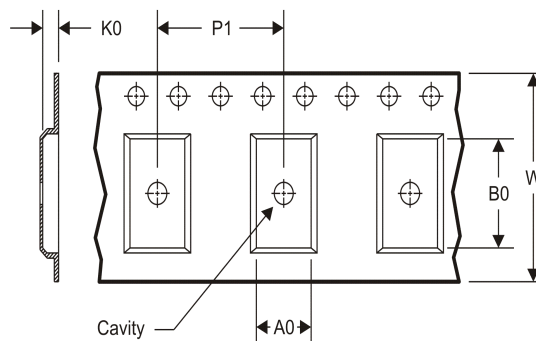
TAPE AND REEL INFORMATION
REEL DIMENSIONS

TAPE DIMENSIONS

A0	Dimension designed to accommodate the component width
B0	Dimension designed to accommodate the component length
K0	Dimension designed to accommodate the component thickness
W	Overall width of the carrier tape
P1	Pitch between successive cavity centers

TAPE AND REEL INFORMATION

*All dimensions are nominal

Device	Package Type	Package Drawing	Pins	SPQ	Reel Diameter (mm)	Reel Width W1 (mm)	A0 (mm)	B0 (mm)	K0 (mm)	P1 (mm)	W (mm)	Pin1 Quadrant
TS3USBA225RUTR	UQFN	RUT	12	3000	180.0	8.4	1.95	2.3	0.75	4.0	8.0	Q1
TS3USBA225RUTR	UQFN	RUT	12	3000	180.0	9.5	1.9	2.3	0.75	4.0	8.0	Q1

TAPE AND REEL BOX DIMENSIONS



*All dimensions are nominal

Device	Package Type	Package Drawing	Pins	SPQ	Length (mm)	Width (mm)	Height (mm)
TS3USBA225RUTR	UQFN	RUT	12	3000	202.0	201.0	28.0
TS3USBA225RUTR	UQFN	RUT	12	3000	180.0	180.0	30.0

RUT (R-PUQFN-N12)

PLASTIC QUAD FLATPACK NO-LEAD

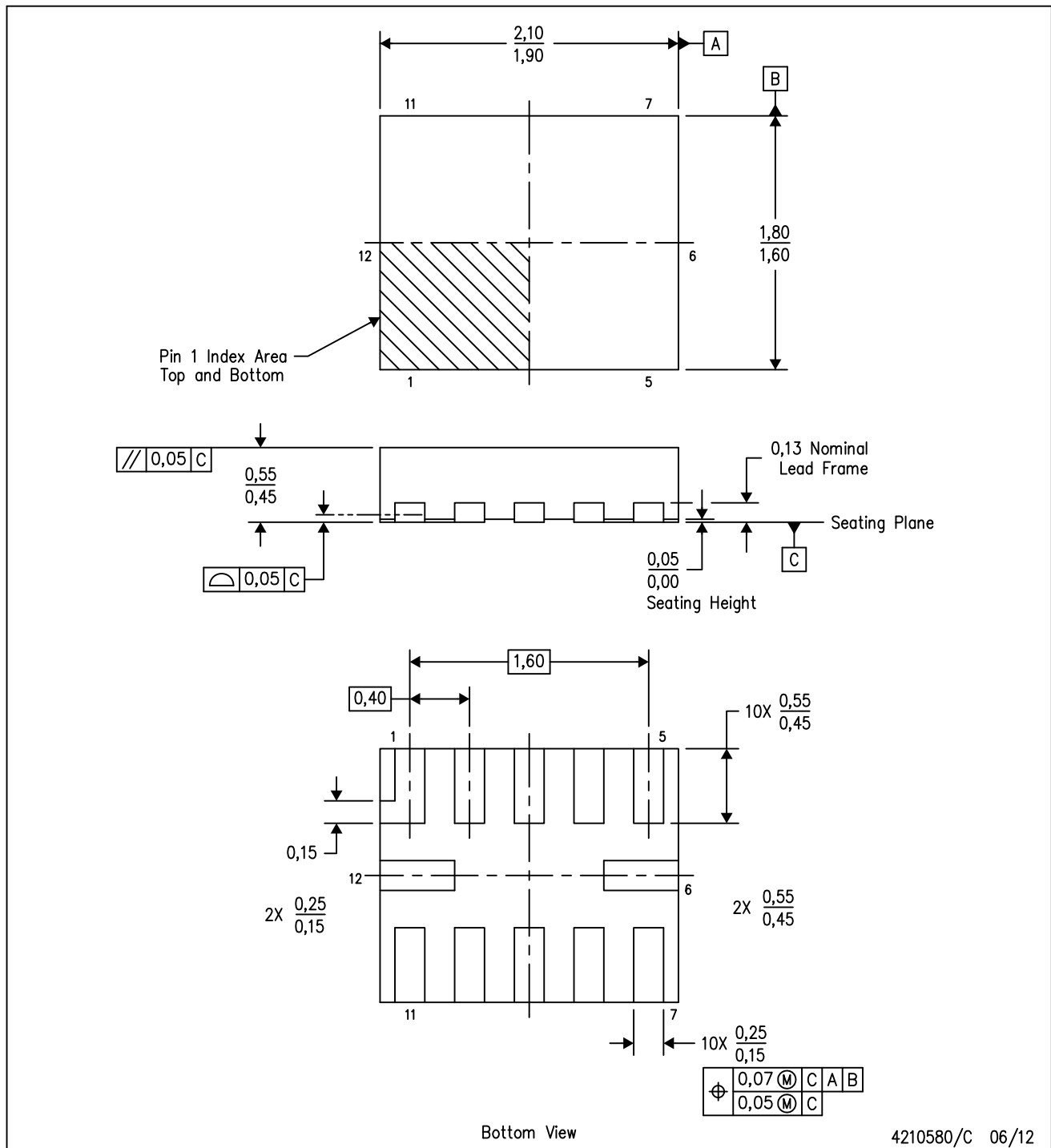

- NOTES:
- All linear dimensions are in millimeters. Dimensioning and tolerancing per ASME Y14.5M-1994.
 - This drawing is subject to change without notice.
 - QFN (Quad Flatpack No-Lead) package configuration.

RUT (R-PUQFN-N12)

PLASTIC QUAD FLATPACK NO-LEAD

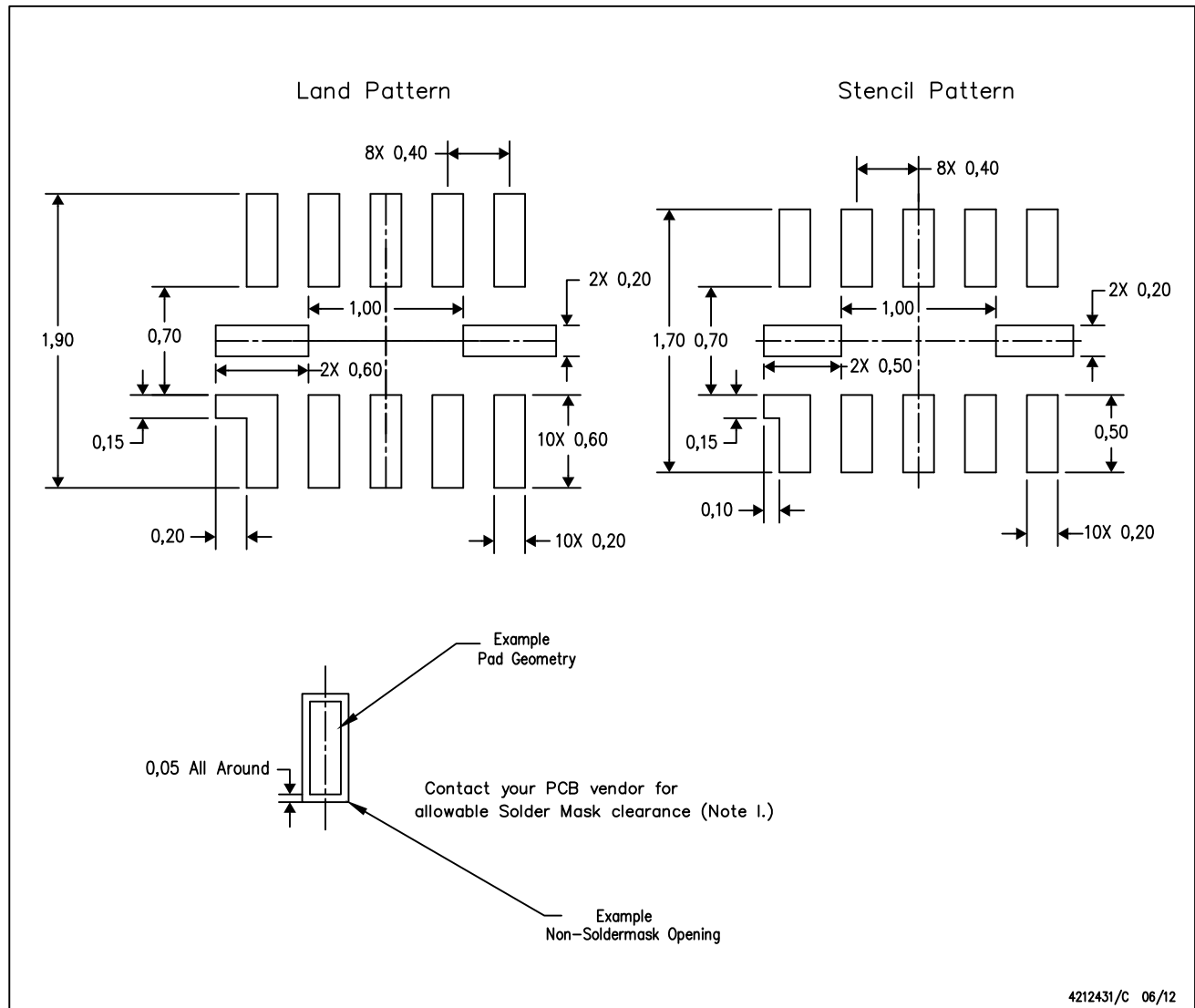

4212431/C 06/12

- NOTES:
- A. All linear dimensions are in millimeters.
 - B. This drawing is subject to change without notice.
 - C. Publication IPC-7351 is recommended for alternate designs.
 - D. Customers should contact their board fabrication site for minimum solder mask web tolerances between signal pads.
 - E. Maximum stencil thickness 0,1016 mm (4 mils). All linear dimensions are in millimeters.
 - F. Laser cutting apertures with trapezoidal walls and also rounding corners will offer better paste release. Customers should contact their board assembly site for stencil design recommendations. Refer to IPC 7525 for stencil design considerations.
 - G. Over-printing land for larger area ratio is not advised due to land width and bridging potential. Exercise extreme caution.
 - H. Suggest stencils cut with lasers such as Fiber Laser that produce the greatest positional accuracy.
 - I. Component placement force should be minimized to prevent excessive paste block deformation.

IMPORTANT NOTICE

Texas Instruments Incorporated and its subsidiaries (TI) reserve the right to make corrections, enhancements, improvements and other changes to its semiconductor products and services per JESD46, latest issue, and to discontinue any product or service per JESD48, latest issue. Buyers should obtain the latest relevant information before placing orders and should verify that such information is current and complete. All semiconductor products (also referred to herein as "components") are sold subject to TI's terms and conditions of sale supplied at the time of order acknowledgment.

TI warrants performance of its components to the specifications applicable at the time of sale, in accordance with the warranty in TI's terms and conditions of sale of semiconductor products. Testing and other quality control techniques are used to the extent TI deems necessary to support this warranty. Except where mandated by applicable law, testing of all parameters of each component is not necessarily performed.

TI assumes no liability for applications assistance or the design of Buyers' products. Buyers are responsible for their products and applications using TI components. To minimize the risks associated with Buyers' products and applications, Buyers should provide adequate design and operating safeguards.

TI does not warrant or represent that any license, either express or implied, is granted under any patent right, copyright, mask work right, or other intellectual property right relating to any combination, machine, or process in which TI components or services are used. Information published by TI regarding third-party products or services does not constitute a license to use such products or services or a warranty or endorsement thereof. Use of such information may require a license from a third party under the patents or other intellectual property of the third party, or a license from TI under the patents or other intellectual property of TI.

Reproduction of significant portions of TI information in TI data books or data sheets is permissible only if reproduction is without alteration and is accompanied by all associated warranties, conditions, limitations, and notices. TI is not responsible or liable for such altered documentation. Information of third parties may be subject to additional restrictions.

Resale of TI components or services with statements different from or beyond the parameters stated by TI for that component or service voids all express and any implied warranties for the associated TI component or service and is an unfair and deceptive business practice. TI is not responsible or liable for any such statements.

Buyer acknowledges and agrees that it is solely responsible for compliance with all legal, regulatory and safety-related requirements concerning its products, and any use of TI components in its applications, notwithstanding any applications-related information or support that may be provided by TI. Buyer represents and agrees that it has all the necessary expertise to create and implement safeguards which anticipate dangerous consequences of failures, monitor failures and their consequences, lessen the likelihood of failures that might cause harm and take appropriate remedial actions. Buyer will fully indemnify TI and its representatives against any damages arising out of the use of any TI components in safety-critical applications.

In some cases, TI components may be promoted specifically to facilitate safety-related applications. With such components, TI's goal is to help enable customers to design and create their own end-product solutions that meet applicable functional safety standards and requirements. Nonetheless, such components are subject to these terms.

No TI components are authorized for use in FDA Class III (or similar life-critical medical equipment) unless authorized officers of the parties have executed a special agreement specifically governing such use.

Only those TI components which TI has specifically designated as military grade or "enhanced plastic" are designed and intended for use in military/aerospace applications or environments. Buyer acknowledges and agrees that any military or aerospace use of TI components which have **not** been so designated is solely at the Buyer's risk, and that Buyer is solely responsible for compliance with all legal and regulatory requirements in connection with such use.

TI has specifically designated certain components as meeting ISO/TS16949 requirements, mainly for automotive use. In any case of use of non-designated products, TI will not be responsible for any failure to meet ISO/TS16949.

Products

Audio	www.ti.com/audio
Amplifiers	amplifier.ti.com
Data Converters	dataconverter.ti.com
DLP® Products	www.dlp.com
DSP	dsp.ti.com
Clocks and Timers	www.ti.com/clocks
Interface	interface.ti.com
Logic	logic.ti.com
Power Mgmt	power.ti.com
Microcontrollers	microcontroller.ti.com
RFID	www.ti-rfid.com
OMAP Applications Processors	www.ti.com/omap
Wireless Connectivity	www.ti.com/wirelessconnectivity

Applications

Automotive and Transportation	www.ti.com/automotive
Communications and Telecom	www.ti.com/communications
Computers and Peripherals	www.ti.com/computers
Consumer Electronics	www.ti.com/consumer-apps
Energy and Lighting	www.ti.com/energy
Industrial	www.ti.com/industrial
Medical	www.ti.com/medical
Security	www.ti.com/security
Space, Avionics and Defense	www.ti.com/space-avionics-defense
Video and Imaging	www.ti.com/video

TI E2E Community

e2e.ti.com